

# RadiantReader User's Guide



**Honeywell**

Rev. B  
November 2017  
P/N 031-4007-001



# RadiantReader User's Guide

## Contents

1	General Information .....	5
2	RadiantReader Specifications .....	7
3	Requirements.....	9
3.1	Minimum Hardware Requirements .....	9
3.2	Minimum Software Requirements.....	9
3.3	Run-Time Requirements.....	9
3.4	User Privilege Requirements .....	9
4	RadiantReader Overview .....	10
5	Network Configuration .....	12
5.1	Configuring RadiantReader .....	12
5.2	Preparation.....	12
5.3	Lightning Surge Protection.....	13
5.4	Connections For Configuration .....	14
5.5	Checking Your Configuration .....	16
5.5.1	Changing To Advanced Mode.....	20
5.5.2	Configuring RadiantReader .....	22
5.5.3	Set The IP Address .....	23
5.5.4	Input The Server IP Address.....	24
5.5.5	Set The RadiantReader's IP Address.....	24
5.5.6	Set The RadiantReader's Channel .....	26
5.5.7	Checking After Configuration .....	28
5.5.8	Connecting Ethernet For Permanent Installation .....	29
6	Using RadiantReaders In A Network.....	30
7	Using Modbus Protocol.....	31
7.1	Communication Setting .....	31
7.2	Message Frame/Communication Procedure .....	32
7.2.1	ModBus RTU.....	32
7.2.2	ModBus TCP .....	32
7.3	Registers Table .....	33
8	Wiring For RS-232 Or RS-485 .....	41
8.1.1	Wiring Without Ethernet .....	41
8.2	Wiring Blocks.....	43
8.3	Grounding.....	44
9	Mounting The RadiantReader .....	44
10	Technical Support .....	47
11	RAE Systems Contacts .....	48

# RadiantReader User's Guide

## WARNINGS

### Read Before Operating

This manual must be carefully read by all individuals who have or will have the responsibility of using, maintaining, or servicing this product. The product will perform as designed only if it is used, maintained, and serviced in accordance with the manufacturer's instructions.

### WARRANTY REGISTRATION

Register your warranty online by visiting:

<http://www.raesystems.com/customer-care>

This ensures that your RadiantReader is registered and ensures that we can let you know of important updates.

### Proper Product Disposal At End Of Life



The Waste Electrical and Electronic Equipment (WEEE) directive (2002/96/EC) is intended to promote recycling of electrical and electronic equipment and their components at end of life. This symbol (crossed-out wheeled bin) indicates separate collection of waste electrical and electronic equipment in the EU countries. This product may contain one or more Nickel-metal hydride (NiMH), Lithium-ion, or Alkaline batteries. Batteries must be recycled or disposed of properly.

At the end of its life, this product must undergo separate collection and recycling from general or household waste. Please use the return and collection system available in your country for the disposal of this product.

# RadiantReader User's Guide

## 1 General Information

The RadiantReader connects wireless gas monitors to a personal computer (PC) for real-time data insight and Management. ProRAE Guardian software can communicate with remote monitors through RadiantReader. Each RadiantReader can wirelessly communicate with up to 50 remote monitors directly. It supports higher capacity of 500 monitors and 5 zones when integrated within a plant-wide deployment. The RadiantReader can plug directly into a PC via a COM port, or one or more RadiantReaders can be networked through a TCP/IP connection via Ethernet to push sensor data to ProRAE Guardian. It also offers RS-232 and RS-485 support. The networked setup allows communication with over 500 remote monitors and enables passive viewing of the system on other PCs running ProRAE Guardian.

The RadiantReader has an internal battery that can run from 25 to 27 hours if PoE (Power over Ethernet) or DC power is disrupted. The battery charges via PoE power and takes approximately 12 hours to be fully charged. It can also be externally powered by 12 to 28 volts DC.

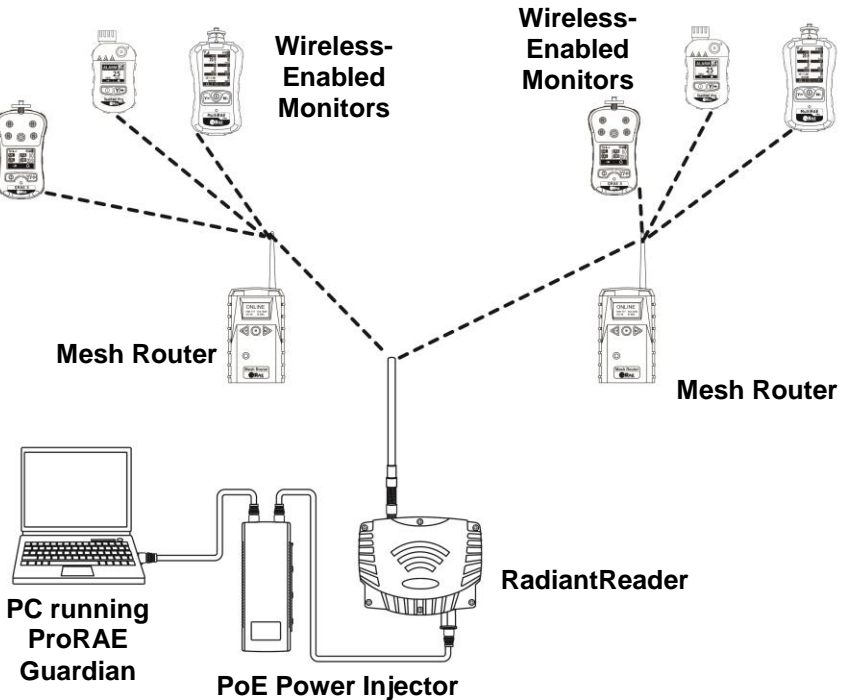

# RadiantReader User's Guide

Radiant Readers can also be used in a closed network such as a LAN, with a network router or switch via TCP/IP.

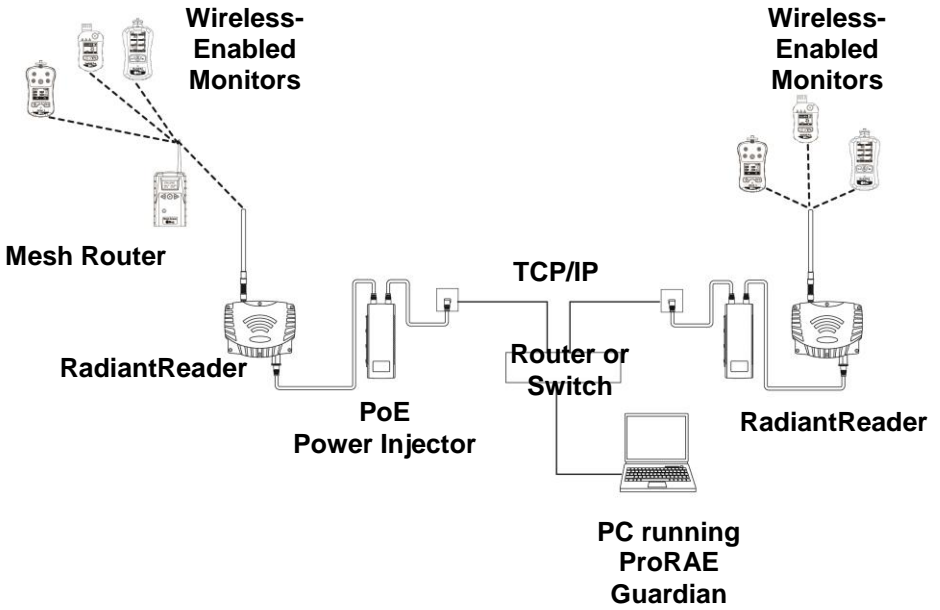

# RadiantReader User's Guide

## 2 RadiantReader Specifications

<b>Operating Range</b>	1,000' (300 m) line of sight
<b>Maximum Monitors Supported</b>	100
<b>Digital Interface</b>	RS-232; Ethernet RJ45 (802.3); RS-485
<b>Power</b>	12 to 28VDC 25W or PoE 25 W at 48V
<b>Backup Battery</b>	7.2V 10Ah
<b>Backup battery run time</b>	25 to 27 hours if power from Ethernet is disrupted
<b>Battery recharge time</b>	Approx. 12 hours on Power over Ethernet
<b>Operating Temperature</b>	-4° to 122° F (-20° to 50° C)
<b>Storage Temperature</b>	-40° to 140° F (-40° to 60° C)
<b>Humidity</b>	10% to 95%, non-condensing (continuous)
<b>Environmental Rating (IP rating)</b>	IP-65
<b>Size</b>	8.6" x 8.5" x 3.4" (21.8 cm x 21.6 cm x 8.6 cm)
<b>Weight</b>	6.2 lb (2.8 kg)
<b>Radio Type</b>	RM900A
<b>Wireless Frequency &amp; Approvals</b>	ISM license-free band 802.15.4 Sub1 GHz FCC Part 15, CE R&TTE Contact RAE Systems for approvals of other countries
<b>RF Output Power</b>	Up to 100 mW
<b>RF Receive Sensitivity</b>	-105dB
<b>Radio Type</b>	RM2400A
<b>Wireless Frequency &amp; Approvals</b>	ISM license-free band ISM 802.15.4 2.4 GHz FCC Part 15, CE R&TTE Contact RAE Systems for approvals of other countries
<b>RF Output Power</b>	Up to 100mW
<b>RF Receive Sensitivity</b>	-104dB

# RadiantReader User's Guide

## **FCC Part 15 Statement**

This device complies with Part 15 of the FCC rules. Operation is subject to the following two conditions: (1) This device may not cause harmful interference, and (2) this device must accept any interference received, including interference that may cause undesired operation.

## 3 Requirements

### 3.1 Minimum Hardware Requirements

- Pentium (or compatible) CPU, 1.0 GHz or better.
- Color monitor (at least 1024x768 resolution, 16-bit color)
- 1GB or more of
- At least 2GB of free hard disk space
- CD-ROM drive
- Sound card (to enable local sound notifications)
- LAN for network connection of RadiantReader(s) through TCP/IP or RS-232

### 3.2 Minimum Software Requirements

Windows 7 or newer, Adobe Acrobat Reader v6.0 or higher (to view online help)

### 3.3 Run-Time Requirements

The PC's "Energy Saving" feature should be set at "Always On." Never turn off the hard disk when ProRAE Guardian software is running. "Hibernate" (if available) must be disabled.

### 3.4 User Privilege Requirements

During installation and operation, you must have administrator privileges on the local PC.

# RadiantReader User's Guide

## 4 RadiantReader Overview

The RadiantReader can be mounted to any flat surface. It has one external port (Ethernet) and two unconnected internal ports (RS-232 and RS-485). It requires DC power or power over Ethernet (PoE), which can be provided by some network switch or a PoE Injector for powering the RadiantReader via Ethernet or connect to an Ethernet switch that provides PoE. The Ethernet port accommodates a standard RJ45 plug connected to an Ethernet cable.

### *Front*

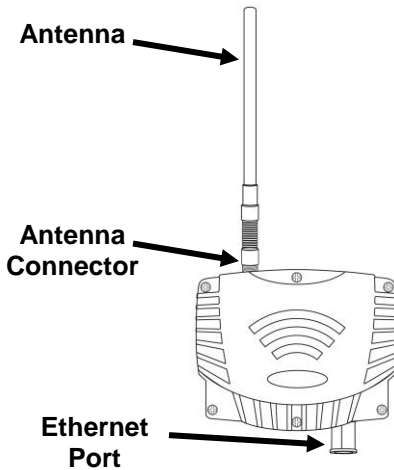

### *Bottom*

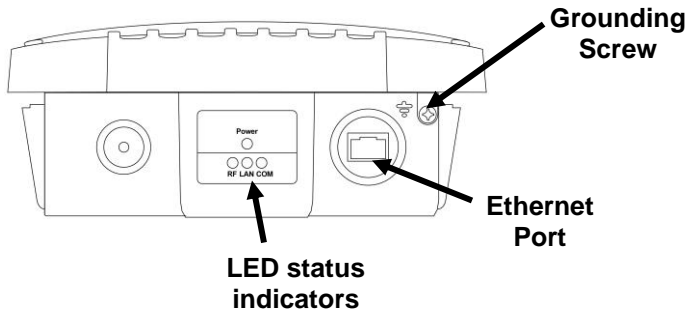

# RadiantReader User's Guide

LED status indicators on the bottom of the RadiantReader provide visual monitors of the following (activity is indicated by blinking, except Power, which glows steadily when power is on):

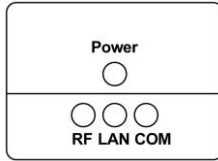

**LED status indicators**

<b>RF</b>	Radio is active/communicating (green LED blinks)
<b>LAN</b>	LAN (via Ethernet port) activity (green LED blinks)
<b>COM</b>	Communication via RS-232 or RS-485 activity (green LED blinks)
<b>Power</b>	<ul style="list-style-type: none"><li>• When PoE is present and internal backup battery charging is finished, the LED glows green continuously.</li><li>• When the battery is being used (PoE is disconnected), the Power LED glows red continuously.</li><li>• When the battery is charging, both Power LED glows yellow continuously.</li></ul>

## 5 Network Configuration

### 5.1 Configuring RadiantReader

An Ethernet cable can be used to connect a RadiantReader via TCP/IP to a computer running ProRAE Guardian on the same network.

**Note:** You must connect the RadiantReader to a small, segregated network that is separate from other networks or the Internet.

### 5.2 Preparation

Before you connect the RadiantReader, you must enable the battery backup, unless you do not want backup power.

1. Open the enclosure by loosening and removing the six screws on the front.

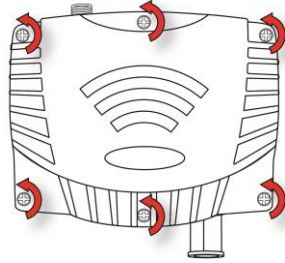

2. Loosen the screws on the wiring block labeled “GND” and “OFF,” and remove the jumper wire.

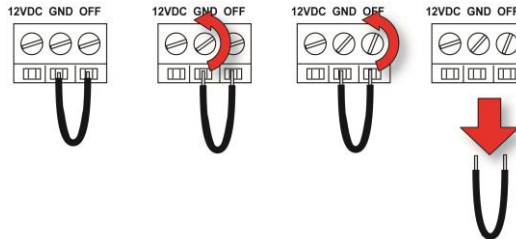

3. Replace the six screws and tighten them to seal the enclosure.

# RadiantReader User's Guide

## 5.3 Lightning Surge Protection

If your RadiantReader or an extension antenna is to be used outdoors, especially if it is to be located in an area prone to lightning, you must install a coaxial lightning surge protector inline between the antenna and the RadiantReader. The lightning surge protector must be earth-grounded: A wire must run directly from the lightning surge protector to a verified ground source such as a copper or copper-clad rod that is set into the ground. A minimum wire gauge of 10AWG or heavier (depending on local electrical ordinance) must be used.

The RadiantReader comes with a coaxial lightning surge protector (P/N: 190-0201-000). If an optional extension cable and antenna are required contact your system's integrator for the correct equipment to be used.

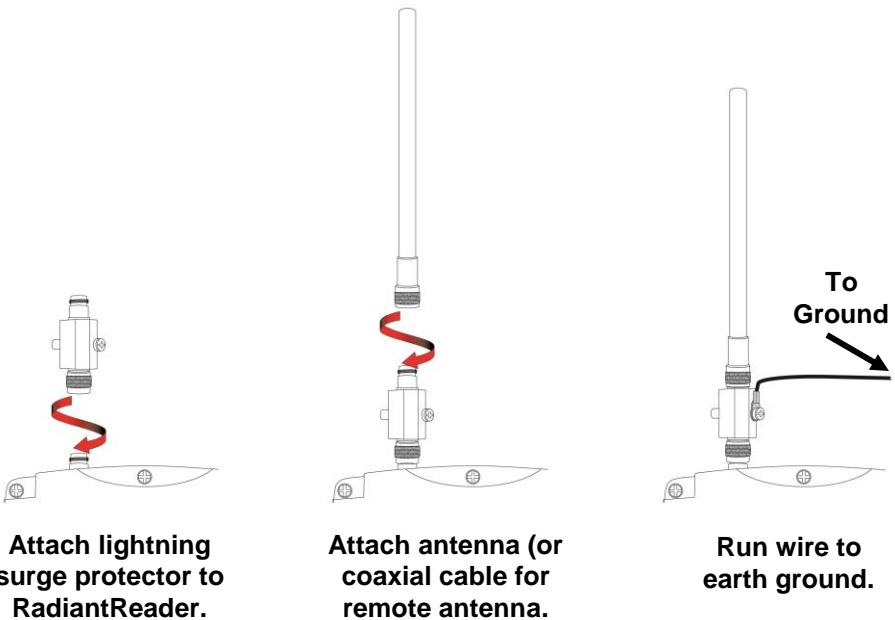

# RadiantReader User's Guide

## 5.4 Connections For Configuration

You will need the following for the simplest way to perform configuration on the RadiantReader:

1. RadiantReader
2. Power over Ethernet power injector
3. Internet Router (not associated with a network)
4. PC with Reader Utility
5. IP Address of the PC that will be running ProRAE Guardian
6. Ethernet cables for connecting:
  - the RadiantReader to the Power Injector
  - the router to the Power Injector
  - the PC running Reader Utility to the router

Using a standard Internet router that is not connected to a network simplifies configuration. Use standard Ethernet Cat-5 cables with RJ-45 plugs to connect the components in the following way:

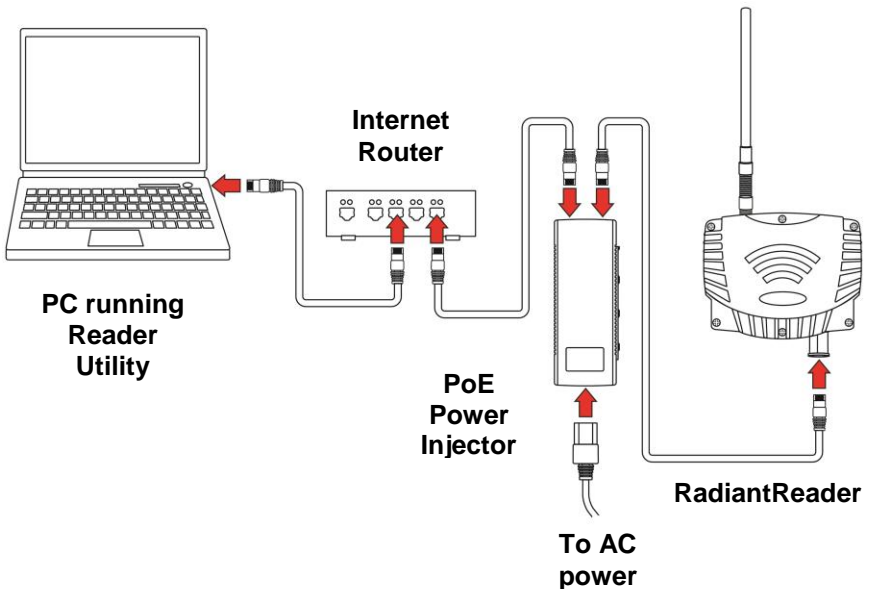

**Note:** The Internet router should not supply power over Ethernet.

# RadiantReader User's Guide

The PoE Power Injector's connections are shown here:

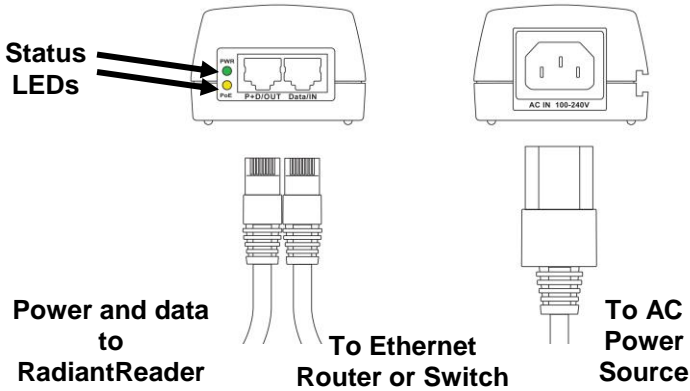

Once connections are made and the Internet router and PoE Power Injector are supplied with power, check that the Internet router is active, that the PoE Injector is working properly (Power and PoE status LEDs are glowing) and that the RadiantReader is functioning (Power LED is on).

**Note:** If the green PWR LED is not glowing, then AC power is not reaching the PoE Injector. If the yellow PoE LED is not glowing, then DC power is not being passed to the RadiantReader.

# RadiantReader User's Guide

## 5.5 Checking Your Configuration

Make sure your connections are set correctly.

Click the “Start” button on your PC.

Click “Control Panel,” and when the menu appears, select “Network and Sharing Center.”

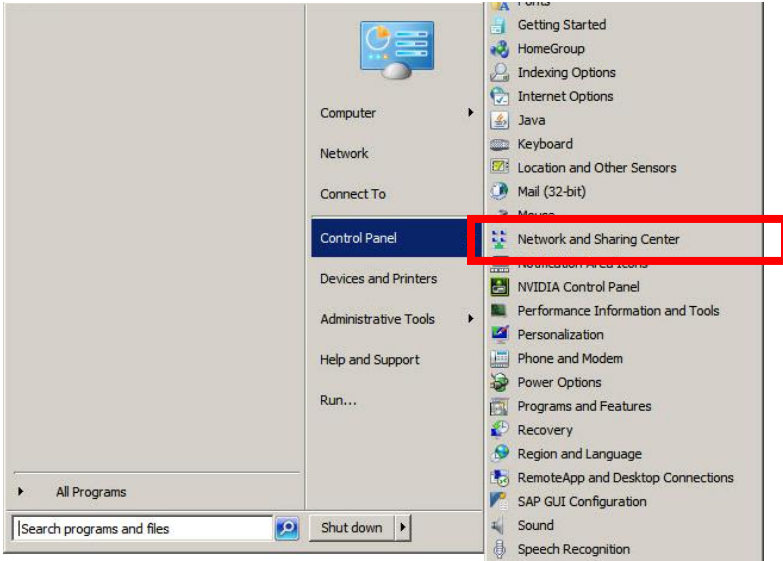

# RadiantReader User's Guide

Click “Local Area Connection.”

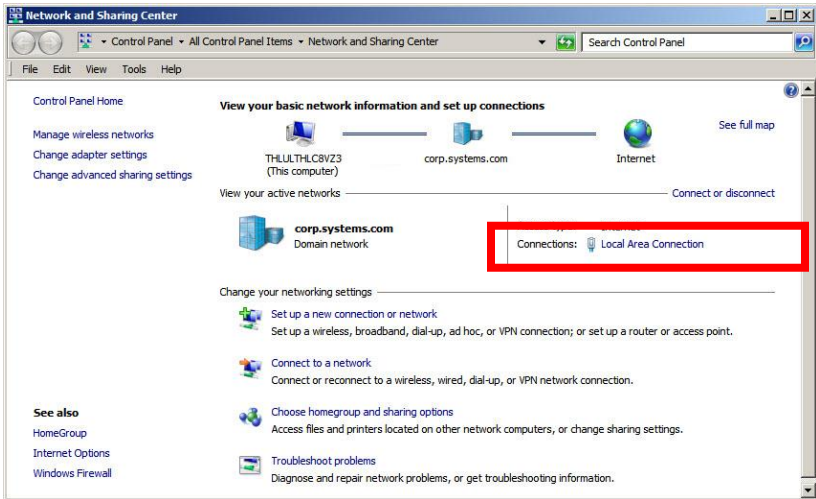

## RadiantReader User's Guide

In the “Local Area Connection Status” window, click “Properties.”

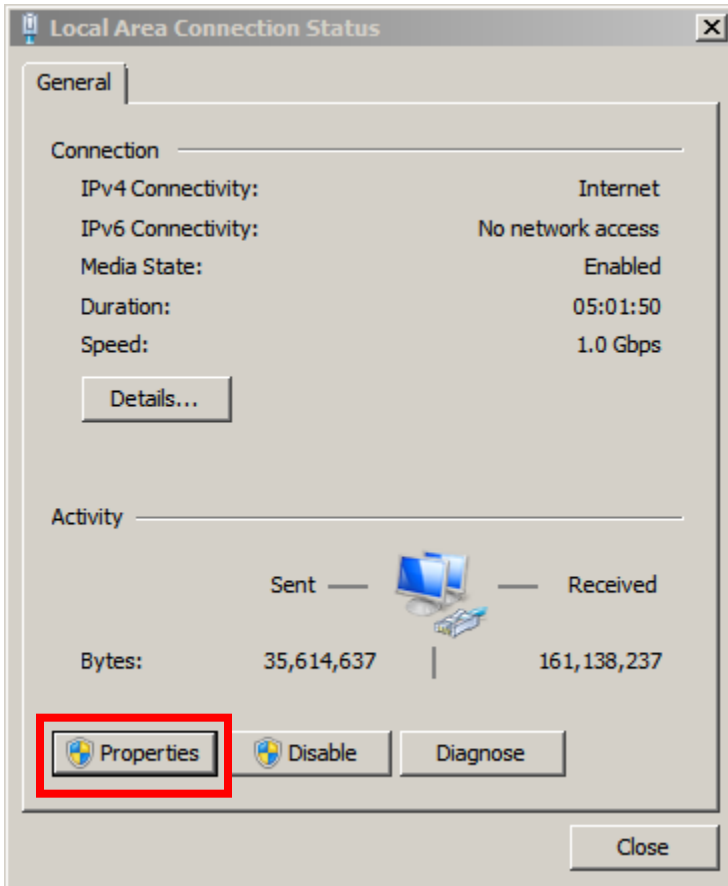

# RadiantReader User's Guide

In the “Local Area Connection Properties” window, make sure that the “Networking” tab is selected and that the box labeled “Internet Protocol Version 4 (TCP/IPv4)” is checked.

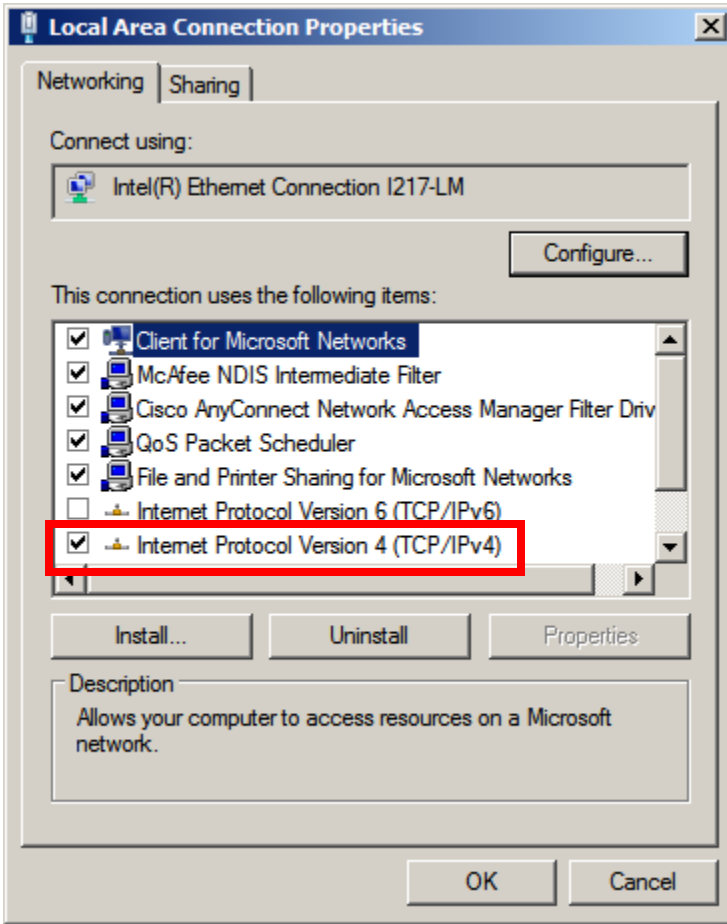

Now click “OK.”

Click “Close” to close the “Local Area Connection Status” window, and then exit “Network and Sharing Center.”

# RadiantReader User's Guide

## 5.5.1 Changing To Advanced Mode

By default, this utility runs in “Regular Operation Mode.” You cannot change any of the RadiantReader’s settings.

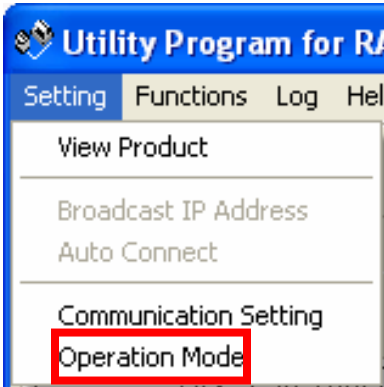

Click “Setting > Operation Mode” to switch to “Advanced Operation Mode.” In the Advanced Mode, you can make changes to the RadiantReader. Click “OK” after making the proper selection.

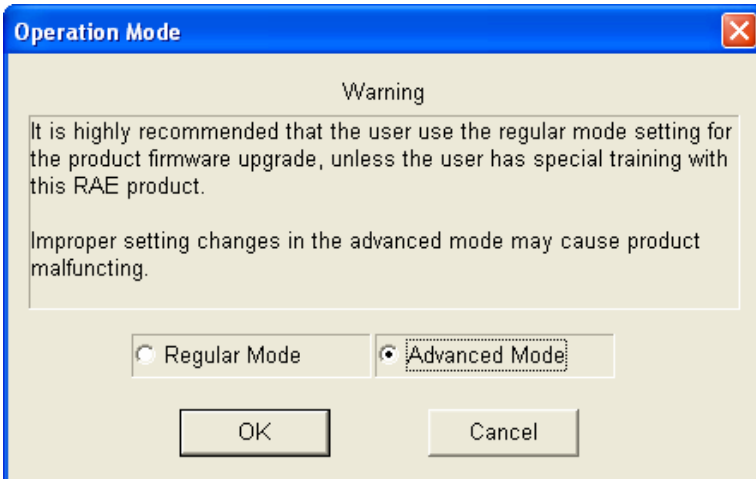

# RadiantReader User's Guide

**Note:** The utility saves the Operation Mode selection and activates this selection the next time it is started.

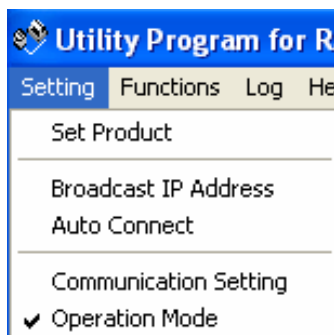

# RadiantReader User's Guide

## 5.5.2 Configuring RadiantReader

Start the Reader Utility by starting ProRAE Guardian, following this path:

Start >> Programs >> RAE Systems by Honeywell >> ProRAE Guardian >> Tools >> Reader Utility

**Note:** If this path does not work, the program may be in another location, with a path like this:

C:\Program Files (x86)\RAE Systems by Honeywell\ProRAE Guardian\tools

file name: RaeDownloader.exe

If the RadiantReader is powered on and it is connected to the RadiantReader to the PC, the RadiantReader is shown in the list:

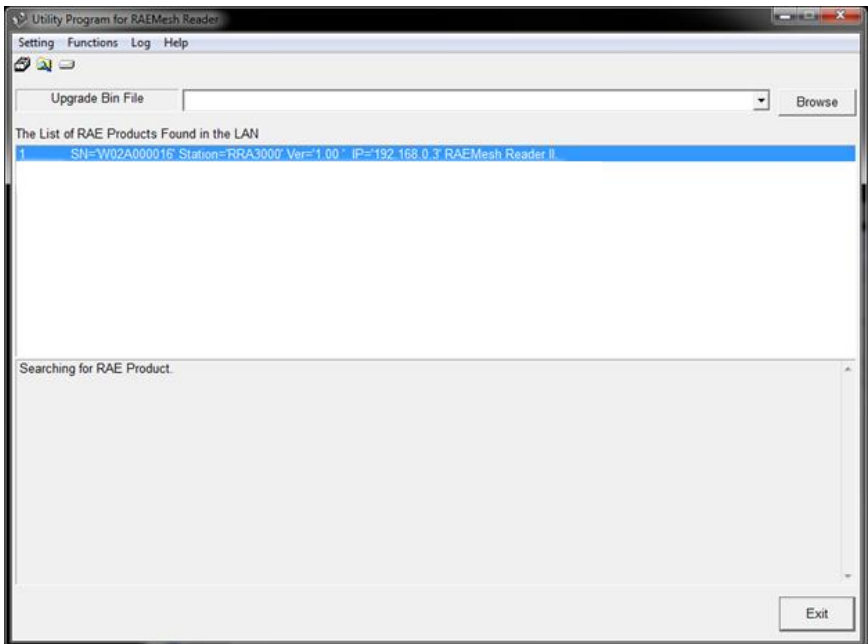

# RadiantReader User's Guide

Double-click on its name. This window appears:

The 'Set Product' window contains the following configuration options:

- Product IP Setting:** IP Address (192 . 168 . 0 . 3), Netmask (255 . 255 . 255 . 0), Gateway (192 . 168 . 0 . 1). Radio buttons for  Static IP and  DHCP.
- Remote PC Setting:** IP Address (192 . 168 . 0 . 4), Data Port (9723), and a **Recommend** button.
- RS485 Setting:** Baudrate (38400) dropdown menu.
- Product Information:** Station (RRA3000), Product (RRA3000), Firmware Version (1.40), Protocol (RCS) dropdown, Serial Number (W02A000016), and Upgrade Count (0).
- Radio Information:** CommID (4D9D), PanID (779) (0~999), Channel (09) (Hex.00~0A), Mode ( Reader,  Reader (Remote),  Router), Radio Type (RM900A), and MAC Address (2E:2A:D3:A6:51:3E).

Buttons at the bottom: **Load**, **Save**, **Set**, **Cancel**.

## 5.5.3 Set The IP Address

If the RadiantReader is set to communicate with ProRAE Guardian via a TCP/IP network, you must set the Reader's IP address and the PC's IP address properly.

**Note:** Network communication is flexible. The RadiantReader can be placed far away from the PC that runs ProRAE Guardian, using a LAN or WAN, provided that a TCP connection can be created.

## RadiantReader User's Guide

### 5.5.4 Input The Server IP Address

Enter the PC's IP address that the ProRAE Guardian runs on and that the RadiantReader will connect to.

#### **Manually confirming a PC's IP address:**

1. Click the **Start** button.
2. Select **Run**.
3. Type **CMD**.
4. Press **Enter**.
5. Type **ipconfig**.
6. Press **Enter**.
7. Several lines of information are displayed. The IP address looks like "**149.72.61.234**".

**Note:** You can get the correct IP address by viewing the "About ProRAE Guardian..." and checking the "PRG IP Address"

If you are using wireless connectivity, look for "Wireless LAN adapter Wireless Network Connection" configuration.

If you are using Ethernet connectivity, look for "Ethernet adapter Local Area Connection" (that is, look for the IPv4 Address).

You will also see the Subnet Mask and Default Gateway.

### 5.5.5 Set The RadiantReader's IP Address

If the LAN has a DHCP server, it is easy to set the RadiantReader's IP address by choosing the default DHCP selection. The DHCP server in the LAN automatically sets the IP address properly after you connect the Reader to the network with an Ethernet cable.

# RadiantReader User's Guide

If there is no DHCP server, you must set a static IP address. Click the “Static IP” option in the “Product IP Address” pane, enter the IP address, Netmask, and Gateway for the RadiantReader.

Alternatively, you can click the “Recommend” button (next to the “Static IP” option) to let the tool select an IP address setting.

**Note:** The utility selects the IP address just next to the current PC’s IP address, the Netmask is set to “255.255.255.0,” and the Gateway is set to the PC’s IP address. This will work for most cases, but it may cause IP address conflicts if any other PC uses this IP address.

The screenshot shows the 'Set Product' configuration window with the following fields and options:

- Product IP Setting:** IP Address: 192 . 168 . 0 . 3; Netmask: 255 . 255 . 255 . 0; Gateway: 192 . 168 . 0 . 1. Radio buttons for  Static IP and  DHCP.
- Remote PC Setting:** IP Address: 192 . 168 . 0 . 4; Data Port: 9723;  button.
- RS485 Setting:** Baudrate: 38400 (dropdown).
- Product Information:** Station: RRA3000; Product: RRA3000; Firmware Version: 1.40; Protocol: RCS (dropdown); Serial Number: W02A000016; Upgrade Count: 0.
- Radio Information:** CommID: 4D9D; PanID: 779 (0~999); Channel: 09 (Hex.00~0A); Mode:  Reader,  Reader (Remote),  Router; Radio Type: RM900A.
- MAC Address:** 2E:2A:D3:A6:51:3E.
- Buttons:** , , , .

# RadiantReader User's Guide

## 5.5.6 Set The RadiantReader's Channel

Set the channel to match your network's channel. This varies according to the frequency of your RadiantReader.

The screenshot shows the 'Set Product' configuration window. It is organized into four main sections:

- Product IP Setting:** IP Address (192 . 168 . 0 . 3), Netmask (255 . 255 . 255 . 0), Gateway (192 . 168 . 0 . 1). Radio buttons for  Static IP and  DHCP.
- Remote PC Setting:** IP Address (192 . 168 . 0 . 4), Data Port (9723) with a **Recommend** button.
- Product Information:** Station (RRA3000), Product (RRA3000), Firmware Version (1.40), Protocol (RCS), Serial Number (W02A000016), Upgrade Count (0).
- Radio Information:** CommID (4D9D), PanID (779) (0~999), Channel (09) (Hex.00~0A), Mode ( Reader,  Reader (Remote),  Router), Radio Type (RM900A).

At the bottom, there is a MAC Address field (2E:2A:D3:A6:51:3E) and buttons for **Load**, **Save**, **Set**, and **Cancel**.

These are the channels that can be used:

868MHz: Channel 0 only

900MHz: Channels 1 through 10

2.4GHz: Channels 11 through 26

## RadiantReader User's Guide

The channel number must be input using hexadecimal values (hex):

Channel	Hex Value	Channel	Hex Value
0	00	14	0E
1	01	15	0F
2	02	16	10
3	03	17	11
4	04	18	12
5	05	19	13
6	06	20	14
7	07	21	15
8	08	22	16
9	09	23	17
10	0A	24	18
11	0B	25	19
12	0C	26	1A
13	0D		

Click “Set” to finish the configuration.

Click “Save” to save the RadiantReader's settings to a .rcf file.

Click “Load” to load the reader settings from a .rcf file.

# RadiantReader User's Guide

## 5.5.7 Checking After Configuration

With the RadiantReader configured with an IP Address, PAN ID, and Channel, you can now connect the RadiantReader to the network on which ProRAE Guardian will be running.

Remove the Internet router from your setup.

If the PC you used to configure the RadiantReader is not the same one that is running ProRAE Guardian, disconnect the configuration PC and connect the PC running ProRAE Guardian to the network that the RadiantReader will be operating on.

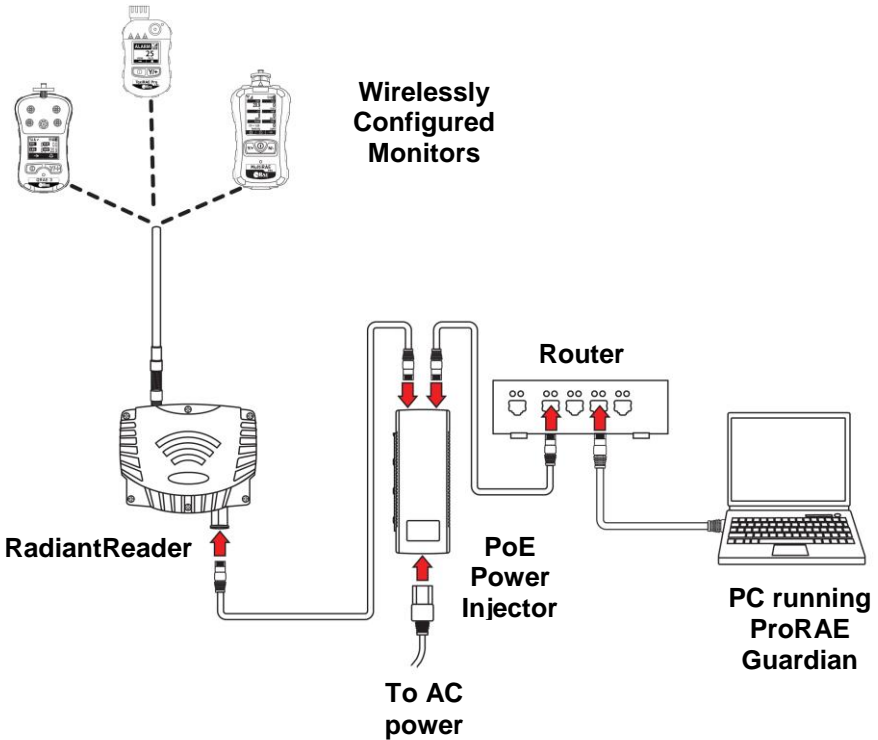

**Note:** If the RadiantReader is connected to a network that provides Power over Ethernet, do not include the PoE Power Injector. Instead connect the RadiantReader straight to the network.

## RadiantReader User's Guide

### 5.5.8 Connecting Ethernet For Permanent Installation

After you have configured the RadiantReader and have it in place for actual use, wire the Ethernet cable through the gland, which acts as a strain relief and a way of keeping contamination out of the Ethernet port.

String the cable through the parts as follows, plug the cable's RJ-45 connector into the Ethernet port, and then tighten the gland's components.

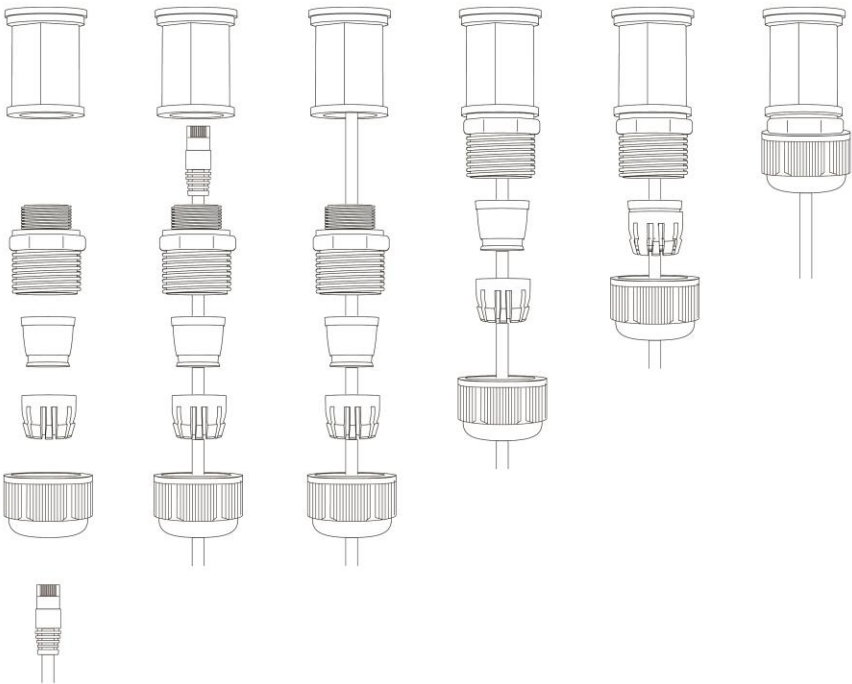

# RadiantReader User's Guide

## 6 Using RadiantReaders In A Network

Employing a router or switch and a TCP/IP network, it is possible to use multiple RadiantReaders (for instance, in large facilities). The diagram below shows a simple view. More “branches” can be added.

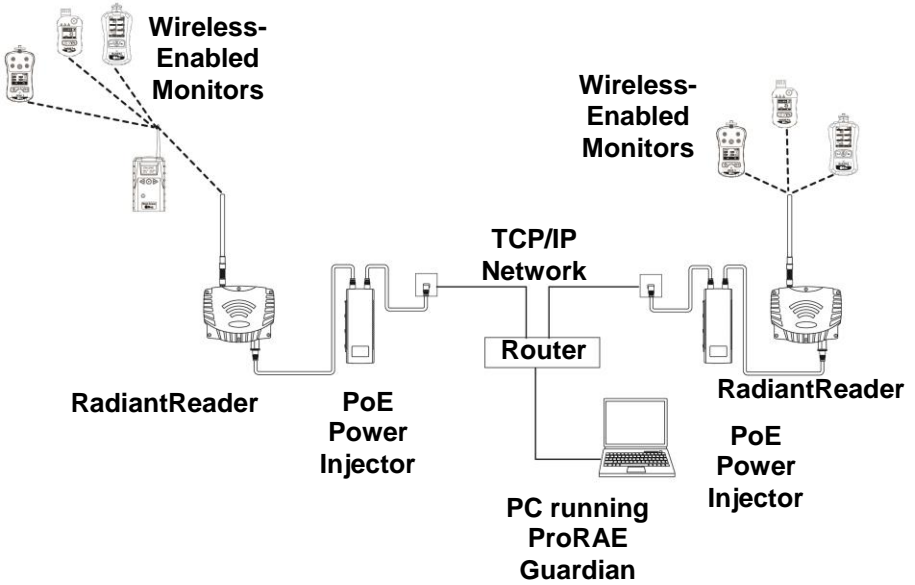

**Note:** If the network provides Power over Ethernet, then you do not need to include a PoE Injector with each RadiantReader. Simply use an Ethernet cable to connect to the network directly from the RadiantReader.

# RadiantReader User's Guide

## 7 Using Modbus Protocol

To use the Modbus protocol for RadiantReader, follow these instructions.

### 7.1 Communication Setting

The two communication modes can be set in the Reader Utility. If changing protocol to MODBUS in Utility, the RadiantReader supports Modbus RTU over RS-485 interface and Modbus TCP over Ethernet interface. Refer to this picture:

The screenshot shows the 'Set Product' configuration window. It contains the following settings:

- Product IP Setting:** IP Address: 10 . 78 . 121 . 243; Netmask: 255 . 255 . 255 . 0; Gateway: 10 . 78 . 121 . 54. Radio buttons for  Static IP and  DHCP.
- Remote PC Setting:** IP Address: 10 . 78 . 121 . 54; Data Port: [empty]; .
- RS485 Setting:** Baudrate: 19200 (dropdown); Slave ID: 1 (text field).
- Product Information:** Station: RRA3000; Product: RRA3000; Firmware Version: 1.40; Serial Number: 915-000001; Upgrade Count: 0; Protocol: MODBUS (dropdown). Buttons for  and .

#### **Mode 1: Modbus RTU over RS485 interface:**

RadiantReader: Slave

Baud Rate: 2400, 4800, 9600, 19200 (default), 38400

Client ID: 1~247(0x01~0xF7)

Data Format:

Data bits: 8

Check bits: none

Stop bits: 1

#### **Mode 2: Modbus TCP over Ethernet interface**

(1) It is the standard Modbus TCP.

(2) The RadiantReader is a server (the default listen port is 502, configurable).

(3) Once a client connects to the server, the client needs to send the request command to RadiantReader to get the monitor information.

# RadiantReader User's Guide

## 7.2 Message Frame/Communication Procedure

**Important!** RadiantReader supports Function Code 0x03 only.

### 7.2.1 ModBus RTU

The Requesting Message:

Device Address	Function Code	Starting Address high byte	Starting Address low byte	Quantity of Registers high byte	Quantity of Registers low byte	CRC low byte	CRC high byte
Client ID	CMD	Addr_H	Addr_L	Qty_H	Qty_L	Crc_L	Crc_H

The Answering Message:

Device Address	Function Code	Byte Count	Register Values	CRC low byte	CRC high byte
Client ID	CMD	len	MSB first	Crc_L	Crc_H

#### Notes:

1. The maximum Quantity of registers value is 48, so Qty H should always be 0.
2. Function code CMD should always be 0x03.

### 7.2.2 ModBus TCP

The Requesting Message:

Transaction Identifier (2 bytes)	Protocol Identifier (2 bytes)	Length field (2 bytes)	Unit identifier (1 byte)	Function code (1 byte)	Starting Address (2 bytes)	Quantity of Registers (2 bytes)
The requestor setting	0x0000	Number of bytes	Client ID	CMD	MSB first	MSB first

# RadiantReader User's Guide

## The Answering Message:

Transaction Identifier (2 bytes)	Protocol Identifier (2 bytes)	length field (2 bytes)	unit identifier (1 byte)	function code (1 byte)	Byte Count (1 bytes)	Register Values (2 bytes)
Copied from requestor	0x0000	Number of bytes	Client ID	CMD	len	MSB first

### Notes:

1. The transaction identifier is produced by the requester. Generally, it is 0.
2. The protocol identifier should be 0x00 for Modbus TCP.
3. The maximum Quantity value is 48, so the quantity of registers high byte should always be 0.
4. Function code CMD should always 0x03.

## 7.3 Registers Table

### (1) 0x03 (Read Holding Registers)

The entire register space is divided into blocks, and each block is a monitor. All monitor data is in one block. One block register space corresponds to a monitor's data registers. A monitor's basic address is located from 0x0000 to 0x05D0 (#1 basic address: 0x0000, #2 basic address: 0x0030, #3 basic address: 0x0060 . . . , #32 basic address: 0x05D0), step value is 0x30.

### Terminology:

**Monitor.** Refer to the actual unit like MeshGuard.

**Sensor.** Refer to the sensor inside the monitor. One monitor may has more than 1 sensor and up to 8

# RadiantReader User's Guide

## The monitor data and register's offset address

Start offset address	Length (2 Bytes)	Response data	Remarks
0x0000	0x0001	byte[0] = Status byte[1] = SysOnlineNum	<b>Status:</b> the monitor data Availability 0: unavailable; 1: available;  <b>SysOnlineNum :</b> the number of online monitors in RadiantReader
0x0001	0x0001	byte[0] = SlaveID high byte[1] = SlaveID low	Monitor unit ID,data format: Hex. Example: UnitID = 0x4011 means the monitor wireless ID is "4011".
0x0002	0x0005	byte[0 ~ 9] = SN[0 ~ 9]	Monitor's serial number:  ASCII, 10 bytes
0x0007	0x0001	byte[0] = InstrID byte[1] = SenSkt	Instrument ID: refer to Appendix 1 Sensor mask to tell you how many sensors.
0x0008	0x0001	byte[0] = UnitErr byte[1]: 0	Monitor unit error status Refer to Appendix 4
0x0009	0x0001	byte[0] = DutyCycle high byte[1] = DutyCycle low	How often the monitor updates its reading
0x000A	0x0001	byte[0] = PwrStatus byte[1] = PwrPer	<b>PwrStatus:</b> 0: Battery only; 1: charging; 2: fully charged+AC 3: AC only  <b>PwrPer:</b> the battery capacity in percentage
0x000B			Field 0x000B reserved for future use

# RadiantReader User's Guide

0x000C	0x0004	byte[0] = SenID byte[1] = UnitID byte[2] = DataFormat B0..B1: DataLength B2..B4: DevideFactor B5..B7: DecimalPoint byte[3] = SenErr byte[4] = Rding higher byte[5] = Rding high byte[6] = Rding low byte[7] = Rding lower	<p><b>First sensor info. Total 8 bytes</b>          SenID: refer to Appendix 2          UnitID: refer to Appendix 3</p> <p><b>For byte2 bit definition:</b>  <b>DataLength :B0:B1</b>          Always          B0:0          B1:1          means 4 bytes</p> <p><b>DivideFactor = 10^n:</b>  <b>B4 B3 B2</b>          0 0 0 - 1          0 0 1 - 10          0 1 0 - 100          0 1 1 - 1000;          1 0 0 ~ 111: reserved for future use</p> <p><b>DecimalPoint:</b>  <b>B7 B6 B5</b>          0 0 0 - 0          0 0 1 - 1          0 1 0 - 2          0 1 1 - 3          1 0 0 ~ 111: reserved for future use</p> <p><b>Note:</b> For instructions on how to perform sensor data calculations, refer to Appendix 6</p> <p><b>SenErr</b>          Refer to Appendix 5</p>
...	...	...	...
0x0028	0x0004	byte[0] = SenID byte[1] = UnitID byte[2] = DataFormat B0..B1: DataLength B2..B4: DevideFactor B5..B7: DecimalPoint byte[3] = SenErr byte[4] = Rding higher byte[5] = Rding high byte[6] = Rding low byte[7] = Rding lower	<p><b>The 8<sup>th</sup> sensor info.</b></p>
0x002C	0x0004	byte[0 ~ 7] = Location String[0 ~ 7]	Location: ASCII & CHN Font code, 8 bytes

# RadiantReader User's Guide

## Appendix 1: Supported Instrument ID

0x00	Unknown
0x01:	MeshGuard
0x02:	RAEWatch
0x03:	RAEtag
0x04:	Router
0x05	ToxiRAE Pro
0x06	MultiRAE
0x07	QRAE3
0x08	RAEPoint Switch

## Appendix 2: Supported Sensor ID

0x00:	Unknown
0x01:	CO
0x02:	H2S
0x03:	LEL
0x04:	GAMMA
0x05:	SO2
0x06:	TEMP
0x07:	MOTION
0x08:	VOC
0x09:	IR
0x0A:	CO2
0x0B:	O2
0x0C	NH3
0x0D	NO2
0x0E	NO
0x0F	Cl2
0x10	ClO2
0x11	ETO
0x12	H2
0x13	HCl
0x14	HCN
0x15	HF
0x16	CH3SH
0x17	COCl2
0x18	PH3
0x19	N2
0x1A	HCHO
0x1B	Neutron

# RadiantReader User's Guide

## Appendix 3: Supported Unit ID

0x00:	" " (Unknown)
0x01:	ppm
0x02:	%
0x03:	uSv/h
0x04:	uR/h
0x05:	DegC
0x06:	w_m2
0x07:	ppb
0x08:	DegF
0x09:	mg/m^3
0x0A:	" " (Space)
0x0B:	%LEL
0x0C:	%VOL

## Appendix 4: Unit error definition

Unit Error byte:

Bit	Description
0 (LSB)	Power – 1 = ON, 0 = Off
1	Battery – 1=Low, 0= Normal
2	Pump – 1=Stall, 0=Normal or not installed
3	Memory – 1=Full, 0=Normal or not installed
4	Sensor mask = bit map for 1-8 sensors
5	Unit Failure – 1=Failure, 0=OK
6	0, reserved for future use
7 (MSB)	0, reserved for future use

# RadiantReader User's Guide

## Appendix 5: Sensor error definition

Sensor Error byte:

Bit	Description
0 (LSB)	Over Range – 1=fail, 0=normal
1	MAX – 1=fail, 0=normal
2	Sensor Failure – 1=fail, 0=normal If Sensor = PID Failure = Lamp Alarm Else if Sensor = LEL Failure = Off Else Failure (General)
3	High limit – 1=fail, 0=normal
4	Low limit – 1=fail, 0=normal
5	STEL limit – 1=fail, 0=normal
6	TWA limit – 1=fail, 0=normal
7 (MSB)	Drift – 1=fail, 0=normal

# RadiantReader User's Guide

## Appendix 6: Sensor data calculation

**Example:** Calculate a sensor data of MeshGuard LEL. The requesting message and the answering message are shown here:

**The Requesting Message :**

01 03 00 C0 00 30 45 E2

**The Answering Message:**

00 01 03 60 01 02 0F E6 64 30 31 35 30 30 31 32 6E 36 01 01 01 00 00 1E 03  
 64 00 00 03 02 06 08 00 00 01 51 00 00 00 00 00 00 00 00 00 00 00 00 00  
 00  
 00 00 00 00 00 00 00 00 00 00 00 00 00 00 00 00 23 23 23 23 23 23 23 62 27 00

0x000C	0x0004	byte[0] = SenID byte[1] = UnitID byte[2] = DataFormat B0..B1: DataLength B2..B4: DevideFactor B5..B7: DecimalPoint byte[3] = SenErr byte[4] = Rding higher byte[5] = Rding high byte[6] = Rding low byte[7] = Rding lower	<p><b>First sensor info. Total 8 bytes</b>                  SenID: Refer to Appendix 2                  UnitID: Refer to Appendix 3</p> <p><b>For byte2 bit definition:</b>  <b>DataLength :B0:B1</b>                  Always                  B0:0                  B1:1                  means 4 bytes</p> <p><b>DivideFactor = 10^n:</b>  <b>B4 B3 B2</b>                  0 0 0 - 1                  0 0 1 - 10                  0 1 0 - 100                  0 1 1 - 1000;                  1 0 0 ~ 111: reserved for future use</p> <p><b>DecimalPoint:</b>  <b>B7 B6 B5</b>                  0 0 0 - 0                  0 0 1 - 1                  0 1 0 - 2                  0 1 1 - 3                  1 0 0 ~ 111: reserved for future use</p> <p><b>Note:</b> For instructions on how to perform sensor data calculations, refer to Appendix 6</p> <p><b>SenErr</b>                  Refer to Appendix 5</p>
--------	--------	---	---

# RadiantReader User's Guide

From the answering message, we can find the DataFormat byte and the reading bytes.

The DataFormat is 06. The reading bytes are 00 00 01 51. Through these bytes and the forward table, it is possible to calculate the reading = 337 and the divider = 10, the DecimalPoint= 0.

The sensor data follows this equation:

$$\text{Sensor Data} = (\text{float})(\text{int})\left(\left(\frac{\text{float data}}{10^{\text{DF}}} + 0.5\right)\right) / 10^{\text{DP}}$$

through the equation

$$\text{Sensor Data} = (\text{float})(\text{int})(337/10+0.5)/1 = (\text{float})(\text{int})34.2/1 = 34$$

# RadiantReader User's Guide

## 8 Wiring For RS-232 Or RS-485

If you need to wire the RadiantReader for RS232 or RS-485 connection, the gland with the RJ-45 jack can be removed and replaced with a gland or similar access junction that accommodates the wiring.

**Note:** All wiring must meet local code requirements.

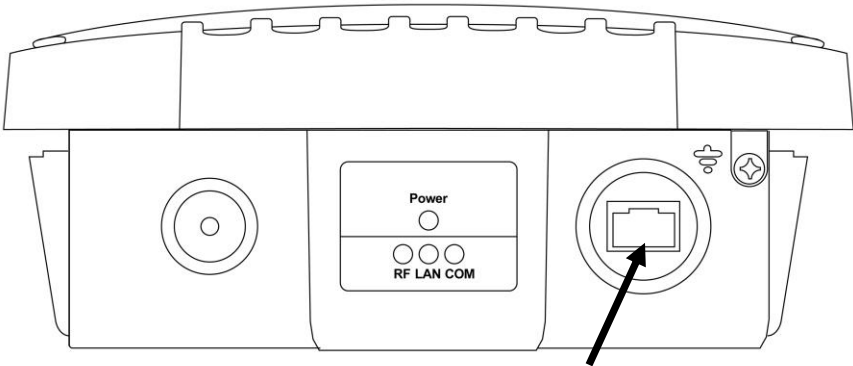

**RJ-45 jack  
in gland**

### 8.1.1 Wiring Without Ethernet

If the RadiantReader is not going to use Ethernet or PoE, then you can remove the RJ-45 module and replace it to accommodate other wiring. Make sure you wrap the cable with sealant before tightening parts. This will help to ensure that water does not get into the RadiantReader where the wires enter.

1. Open the RadiantReader.
2. Disconnect the RJ-45 Ethernet module from the PC board.
3. Loosen the nut that secures the gland to the RadiantReader housing.
4. Disassemble the gland and pass a cable through as shown.
5. Wrap the cable with sealant at the point where the gland will grip the cable.

## RadiantReader User's Guide

6. Tighten the nut to “shrink” the gland’s clamp around the cable.
7. Pass the gland and cable through the RadiantReader’s opening and tighten the nut.
8. Connect the wires to the power and RS-232 or RS-485 blocks.

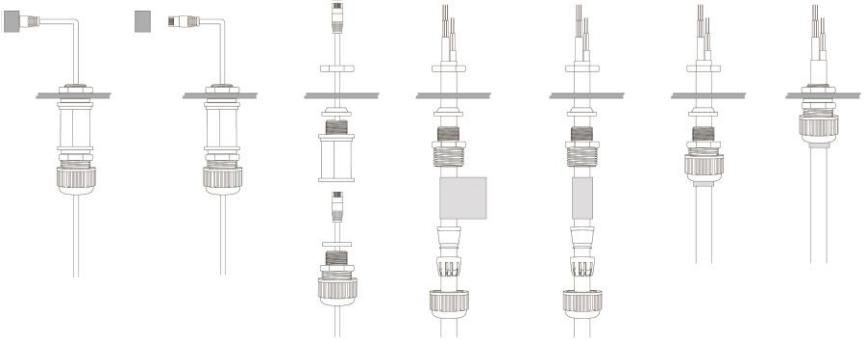

# RadiantReader User's Guide

## 8.2 Wiring Blocks

On the main PC board inside the RadiantReader are two wiring blocks for RS-232 and RS-485. Place wires into the openings on the front of the blocks and then tighten the screws to hold them securely.

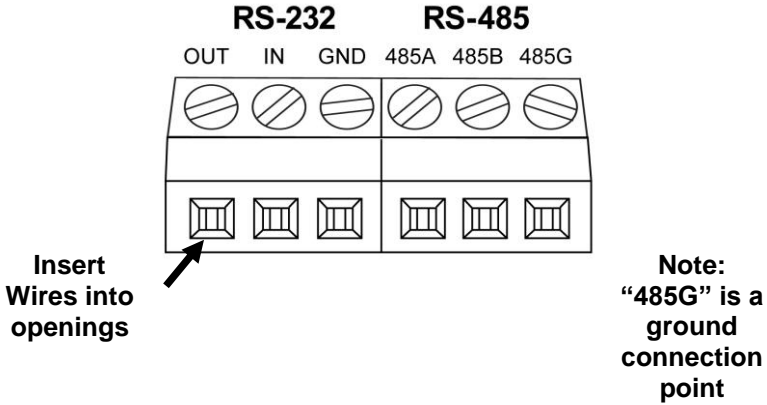

### Schematic diagram of PC board locations

Note: SW2 and P5 (card reader slot) are for factory service only.

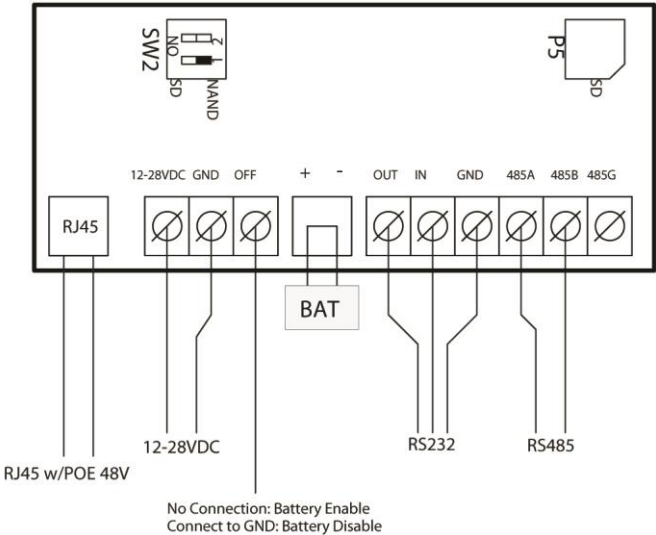

# RadiantReader User's Guide

## 8.3 Grounding

Follow local electrical codes when installing and using the RadiantReader. If direct grounding is required, connect a ground wire to the screw on the bottom of the instrument to ground the chassis.

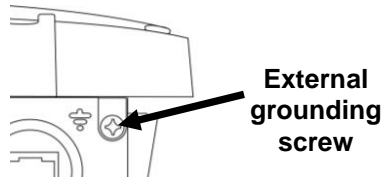

## 9 Mounting The RadiantReader

The RadiantReader may be placed on top of any stable platform, wall-mounted, or pole-mounted. A mounting kit (P/N: W02-3004-000) includes all parts necessary for mounting the RadiantReader to the mounting plate for wall mounting or attaching to a pole. The kit includes two bracket clips for pole attachment.

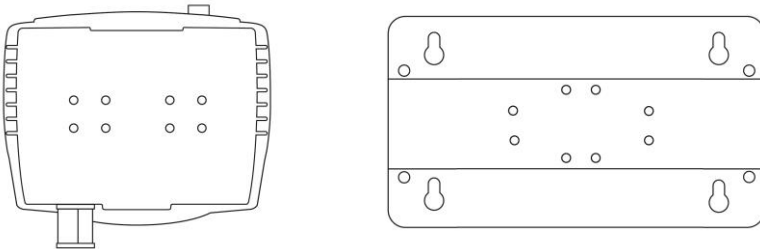

**Eight drilled, tapped holes on the rear of RadiantReader are designed to accept the screws that hold the mounting plate.**

# RadiantReader User's Guide

The mounting plate can be attached two ways, allowing the plate to be positioned for vertical mounting (to a pole) or for horizontal mounting (to a wall).

## Wall Mounting

1. Use the plate as a template to mark and drill holes in the wall to accommodate screws to hold the mounting plate. If necessary, install anchors (if mounting plate is to be fastened to a masonry or brick wall).
2. Fasten the mounting plate to the RadiantReader, using four screws as shown below.
3. Fasten the mounting plate to the wall with four screws through the keyhole-shaped holes.

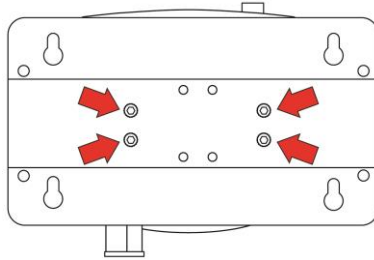

**Position screws for attaching the RadiantReader for wall mounting.**

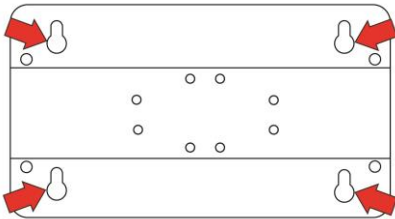

**Attach the mounting plate to the wall using the screws that pass through the four keyhole-shaped holes.**

# RadiantReader User's Guide

## Pole Mounting

1. Fasten the mounting plate to the RadiantReader, using four screws as shown below.
2. Hold the RadiantReader and plate unit against the pole where it is to be mounted, and slide the U-shaped mounting screws' ends through the top and bottom holes of the plate as shown.
3. Put washers and nuts on the ends of the mounting screws and tighten them until the entire unit is firmly attached to the pole.

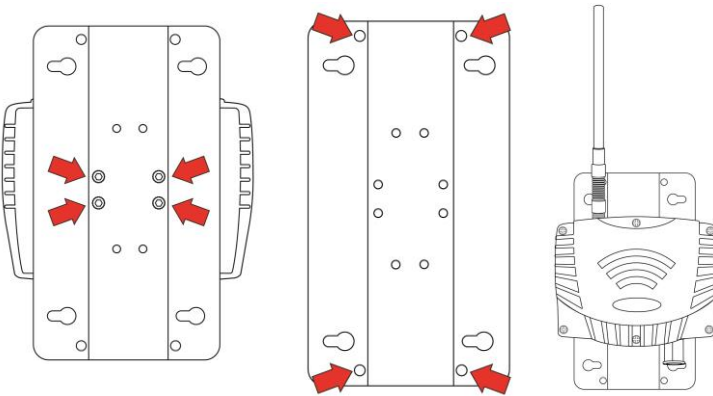

**Insert and tighten four screws as shown. Then mount the combined RadiantReader/mounting plate assembly.**

# RadiantReader User's Guide

## 10 Technical Support

To contact RAE Systems by Honeywell Technical Support:

Monday through Friday, 7:00AM to 5:00PM Pacific (US) Time

**Phone (toll-free):** +1 888-723-4800

**Phone:** +1 408-952-8461

**Email:** RAE-tech@honeywell.com

Outside the Americas:

**E-Mail:** HAexpert@honeywell.com

### **Honeywell Analytics Ltd.**

4 Stinsford Road

Nuffield Industrial Estate

Poole, Dorset, BH17 0RZ

United Kingdom

Tel: +44 (0) 1202 645 544

Fax: +44 (0) 1202 645 555

### **Honeywell Analytics**

Elsenheimerstrasse 43

80687 München

Germany

Tel: +49 89 791 92 20

Fax: +49 89 791 92 43

### **Honeywell Analytics**

ZAC Athélia 4 – 375 avenue du  
Mistral

Bât B, Expace Mistral

13600 La Ciotat

France

Tel: +33 (0) 4 42 98 17 75

Fax: +33 (0) 4 42 71 97 05

### **Honeywell Analytics**

P.O. Box-45595

6th Street

Musaffah Industrial Area

Abu Dhabi

UAE

Tel: +971 2 554 6672

Fax: +971 2 554 6672

## 11 RAE Systems Contacts

### **RAE Systems by Honeywell World Headquarters**

1349 Moffett Park Dr.  
Sunnyvale, CA 94089 USA

**Phone:** 408-952-8200

**Toll-Free:** 888-723-4800

**E-mail:** [RAE-tech@honeywell.com](mailto:RAE-tech@honeywell.com)

**Web Site:** [www.raesystems.com](http://www.raesystems.com)

# Honeywell

## **RAE Systems by Honeywell**

### **World Headquarters**

1349 Moffett Park Dr.

Sunnyvale, CA 94089 USA

Phone: 408.952.8200

Toll-Free: 888.723.4800

**E-mail (technical support):** [RAE-tech@honeywell.com](mailto:RAE-tech@honeywell.com)

**Web Site:** [www.raesystems.com](http://www.raesystems.com)

## **WORLDWIDE SALES OFFICES**

**USA/Canada** 1.877.723.2878

**Europe/Africa** 00800.333.222.44 (freephone)

+41.44.943.4380

**Middle East** +971.4.450.5852 (portables)

**China** +86.10.5885.8788-3000

**Asia Pacific** +852.2669.0828

Rev. B

November 2017

P/N 031-4007-001



**D**ETECTION | **S**AFETY | **P**ROTECTION

For Pricing or Further  
Information Please Contact Us.



**+441158390495**



**[www.manonglobal.com](http://www.manonglobal.com)**



**[sales@manonglobal.com](mailto:sales@manonglobal.com)**

---

**Leading UK Suppliers In  
Gas Detection, Safety & Protection  
Products  
Brand New & Genuine OEM Parts  
UK & Worldwide Deliveries Available**



Worldwide Delivery



1000+ Genuine Parts & Equipment