



Touchpoint Plus Wireless

Revision History

Issue	Comment	ECO no.	Date
1	Initial Release	HAA190023	Mar 2019
2	Second Release for Portable Products	HAA190054	Sep 2019

Disclaimer

In no event shall Honeywell be liable for any damages or injury of any nature or kind, no matter how caused, that arise from the use of the equipment referred to in this manual.

Strict compliance with the safety procedures set out and referred to in this manual, and extreme care in the use of the equipment, are essential to avoid or minimise the chance of personal injury or damage to the equipment.

The information, figures, illustrations, tables, specifications, and schematics contained in this manual are believed to be correct and accurate as at the date of publication or revision. However, no representation or warranty with respect to such correctness or accuracy is given or implied and Honeywell will not, under any circumstances, be liable to any person or corporation for any loss or damages incurred in connection with the use of this manual.

The information, figures, illustrations, tables, specifications, and schematics contained in this manual are subject to change without notice.

Unauthorised modifications to the gas detection system or its installation are not permitted, as these may give rise to unacceptable health and safety hazards.

Any software forming part of this equipment should be used only for the purposes for which Honeywell supplied it. The user shall undertake no changes, modifications, conversions, translations into another computer language, or copies (except for a necessary backup copy).

In no event shall Honeywell be liable for any equipment malfunction or damages whatsoever, including (without limitation) incidental, direct, indirect, special, and consequential damages, damages for loss of business profits, business interruption, loss of business information, or other pecuniary loss, resulting from any violation of the above prohibitions.

Warranty

Honeywell Analytics warrants the Touchpoint Plus Wireless system against defective parts and workmanship, and will repair or (at its discretion) replace any components that are or may become defective under proper usage within 12 months from the date of commissioning by a Honeywell Analytics approved representative* or 18 months from shipment from Honeywell Analytics, whichever is sooner.

This warranty does not cover consumable, batteries, fuses, normal wear and tear, or damage caused by accident, abuse, improper installation, unauthorized use, modification or repair, ambient environment, poisons, contaminants or abnormal operating conditions.

This warranty does not apply to sensors or components that are covered under separate warranties, or to any 3rd-party cables and components

Any claim under the Honeywell Analytics Product Warranty must be made within the warranty period and as soon as reasonably practicable after a defect is discovered. Please contact your local Honeywell Analytics Service representative to register your claim.

This is a summary. For full warranty terms refer to the Honeywell Analytics' *General Statement of Limited Product Warranty*, which is available on request.

* A Honeywell Analytics approved representative is a qualified person trained or employed by Honeywell Analytics, or a qualified person trained in accordance with this manual.

Copyright Notice

Microsoft, MS and MS-DOS are registered trademarks of Microsoft Corp.

Other brand and product names mentioned in this manual may be trademarks or registered trademarks of their respective companies and are the sole property of their respective holders.

Honeywell is the registered trademark of Honeywell Safety and Productivity Solutions (SPS).

Find out more at www.honeywellanalytics.com

Contents

Chapter 1 – Important Safety Information	1
1.1 Cautions	3
1.1.1 Intended Readers	3
1.1.2 Conventions Used	3
1.1.3 Associated Manuals	3
Chapter 2 – Safety Hazards, Warnings and Cautions	4
2.1 Safety	4
2.1.1 Warnings and Cautions	4
2.1.2 Safety Hazards	5
2.2 Location and Description of Warning Labels	7
2.2.1 Safety Warning Labels	7
2.3 Electrical Hazards	8
2.3.1 General Precautions	8
2.3.2 Component Testing and Replacement	8
2.3.3 Antistatic Precautions	9
2.3.4 Good Practice	9
2.3.5 Lithium Battery Hazard	9
2.4 Product Compliance	10
2.5 Conditions of Use	11
2.5.1 Training of Personnel	11
2.5.2 Conditions Satisfying Local, National and International Safety Regulations	11
2.5.3 Due Authorisation	11
2.5.4 Approved Maintenance and Servicing Procedures	11
2.6 Security Guide	11
Chapter 3 – System General Description	12
3.1 Equipment Specification	14
3.1.1 Power Requirements	14
3.1.2 Weights	15
3.1.3 Dimensions	15
3.1.4 Ambient Operating Temperature	15
3.1.5 Overall Ambient Operating Humidity	15
3.1.6 Storage Conditions (Without batteries)	15
3.1.7 Storage Conditions (With batteries)	15
3.1.8 IP Rating	15
3.1.9 Construction	16
3.1.10 Touchpoint Plus Wireless Packaging	16
3.1.11 Packaging Components for Return to Manufacturer	16
3.1.12 Disposal (WEEE Directive)	16
3.2 System Construction	17
Chapter 4 – System Mechanical Installation	18
4.1 How to Open and Close the Enclosure	19
4.2 Wall Mounting Requirements	20
4.2.1 Wall Mount Fixings	21
Chapter 5 – Electrical Power Connection and Interfacing	23
5.1 Power Connection	23
5.1.1 AC Power Supply	24
5.1.2 DC Power Supply	25
5.1.3 Backup Battery Pack	25
5.2 Cabling Requirements	26
5.2.1 AC Mains Voltage Power Cables	26
5.2.2 DC Power Cables	26
5.2.3 Field Device Cables	26
5.2.4 Main Module Connections	27
5.2.5 mA Input Module Connections	29
5.2.6 Grounding	31
5.2.7 Wireless Module Connections	33

Contents

5.2.8 Antenna Installation.....	34
5.2.9 Antenna Extension Connection.....	34
5.2.10 FA324 Connection.....	35
5.2.11 RAEMet Wind Sensor Connection.....	37
5.2.12 Relay Output Module Connections.....	39
Chapter 6 – Touchpoint Plus Wireless Operating Instructions.....	41
6.1 User Interface General.....	41
6.2 Menu Items and Access Levels.....	42
6.2.1 Touchscreen (Colour Resistive).....	45
6.3 SD Card.....	45
6.4 Normal Operation (Safety Functions).....	46
6.5 Overview – Touchscreen Interface.....	46
6.5.1 User Interface Screen.....	46
6.5.2 Navigation – Active Events and Filtering.....	48
6.5.3 Navigation – Menu.....	49
6.5.4 Navigation – Active Access Level Icons.....	50
6.6 Alarms.....	50
6.6.1 View active alarms.....	50
6.6.2 Acknowledge an active alarm.....	51
6.6.3 Reset a latched alarm.....	51
6.7 Faults and Warnings.....	52
6.7.1 View Faults and Warnings.....	52
6.7.2 Acknowledging an Active Fault or Warning.....	52
6.7.3 Reset a Latched Fault or Warning.....	52
6.8 Inhibit.....	53
6.9 Viewing Input Channels and Input Details.....	53
6.10 Viewing the Trend Graph.....	55
6.11 Viewing Event History and Export.....	55
6.12 Checking the Capacity of the SD Card.....	55
6.13 Accessing the System Information and Service Contact Details.....	56
6.14 System State Relays.....	56
Chapter 7 – Commissioning.....	57
7.1 Introduction.....	57
7.2 First Time Switch On.....	57
7.3 Date, Time and Language Settings.....	58
7.3.1 How to Set or Change Date, Time and Language Settings:.....	58
7.4 Program Passwords.....	58
7.5 Commission Input / Output Modules.....	59
7.6 Channel Configuration.....	60
7.6.1 Introduction.....	60
7.6.2 Wireless Network Setting (Mesh Network).....	61
7.6.3 Configuring a Channel.....	62
7.6.4 Editing a Configured Channel.....	63
7.6.5 Configuring Wireless inputs.....	64
7.6.6 Configuring Relay Output Channels.....	65
7.6.7 Configuring Wireless output.....	68
7.6.8 Programming FA324.....	69
7.7 Data Logging.....	72
7.8 Touch Panel Configuration.....	73
7.8.1 How to Calibrate the Touch Panel.....	73
7.9 Service Contact Settings.....	73
7.10 Back up Configuration.....	74
7.11 Calibrate mA Input Channel Loops.....	75

Contents

7.12 Calibrate Wireless Input Channel	75
Chapter 8 – Maintenance	76
8.1 Routine Maintenance	76
8.1.1 Weekly Checks	76
8.1.2 Exercising the Relays	77
8.1.3 Exercising Audio/Visual Alarm	77
8.1.4 LCD Test	77
8.1.5 LED and Buzzer Test	77
8.1.6 Mesh Network Test	77
8.2 Testing the Touchpoint Plus Wireless System	78
8.2.1 Introduction	78
8.3 How to Replace a Faulty I/O Module	79
8.4 How to Add a New I/O Module	80
8.5 How to Remove or Decommission an I/O Module	81
8.6 How to Update the Sensor Catalogue	81
8.7 How to Backup / Restore Configuration	82
8.8 How to Update Firmware	83
8.8.1 How to Check System Compatibility	83
8.8.2 How to Update the Firmware	83
8.9 How to Change the SD Card	84
8.10 Back up Battery Maintenance	85
8.10.1 Recommended Scheduled Maintenance	85
8.10.2 How to Replace the Battery Pack	85
8.11 Return to Factory Setting	86
Chapter 9 – Troubleshooting	87
9.1 Calling for Technical Support	87
Chapter 10 – Technical Specifications	88
10.1 Environmental	88
10.2 User Interface and Main Module	88
10.3 I/O Modules	89
10.3.1 mA Input Module	89
10.3.2 Relay Output Module	89
10.3.3 Wireless Module	89
10.4 Power Supplies	90
10.4.1 External Supplies	90
10.4.2 Backup Battery	90
10.5 Enclosures	90
10.5.1 Wall Mount Enclosure	90
Chapter 11 Certifications	91
11.1 EC Declaration of Conformity	91
11.2 National and International Certificates of Compliance	92
Chapter 12 Replacement Parts and Optional Extras	93
Chapter 13 – Glossary of Icons	95
Chapter 14 Configurable Parameter Reference Guide	99
Chapter 15 Event Codes	110
Chapter 16 – List of Figures	118
Chapter 17 – List of Tables	119

Important Safety Information

Chapter 1 – Important Safety Information

The Equipment referred to in this manual contains components and assemblies that are each certified for use in a variety of differing environments, and it is the site owner's responsibility to confirm the suitability of the equipment prior to its installation and use.

The Equipment assemblies referred to in this manual are collectively certified for use in a flammable gas detection system only. Any other use is not currently certified and is not authorised by the manufacturer.

Check the product rating plate and look for the following marks to ensure that the supplied equipment is suitable for its intended location and purpose:

 Products bearing the CE mark conform to all applicable European Directives as stated on the Honeywell product specific EC Declaration of Conformity.

 Products bearing the UL mark conform to the requirements for Ordinary Locations. The letters C and US mean that the product is certified for use in Canada and the United States of America.

WARNING

FOR SAFETY REASONS THIS EQUIPMENT MUST BE OPERATED BY QUALIFIED PERSONNEL ONLY.
READ AND UNDERSTAND THE INSTRUCTION MANUAL COMPLETELY BEFORE OPERATING OR
SERVICING THE EQUIPMENT.

ATTENTION

POUR DES RAISONS DE SÉCURITÉ, CET ÉQUIPEMENT DOIT ÊTRE UTILISÉ, ENTRETENU ET RÉPARÉ
UNIQUEMENT PAR UN PERSONNEL QUALIFIÉ. ÉTUDIER LE MANUEL D'INSTRUCTIONS EN ENTIER
AVANT D'UTILISER, D'ENTREtenir OU DE RÉPARER L'ÉQUIPEMENT.

Important Safety Information

WARNINGS

- 1) The equipment specified in this manual is only to be installed by the Manufacturer's trained personnel, or by competent persons trained in accordance with the Manufacturer's installation instructions.
- 2) Installation must be in accordance with the recognized standards of the appropriate authority in the country concerned. Refer to local, national and company regulations.
- 3) Do not operate the Touchpoint Plus Wireless system or its components outside of their rated operating specification.
- 4) Touchpoint Plus Wireless must not be operated in Oxygen enriched atmospheres, i.e. greater than 25% v/v Oxygen.
- 5) All equipment containing a User Interface must be suitably protected from direct sunlight and rain.
- 6) Power Supply Fluctuations are not to exceed DC 18 – 32 V SELV Supply or ± 10 % of nominal.
- 7) All versions of Enclosure apparatus are electrical Class 1, and must be connected to Protective Earth (Ground).
- 8) The Touchpoint Plus Wireless installation must include a means of isolating or disconnecting the input voltage supply. The isolation or disconnection device must be conveniently located close to the system and be clearly labelled. For an AC mains voltage supply, the isolation or disconnection device must disconnect both the line and neutral poles, but maintain earth (ground) continuity.
- 9) The Touchpoint Plus Wireless input voltage supply must include over-current protection.
- 10) All cabling must be appropriately rated and approved in accordance with local, national and company regulations, and suitable for the installation. Additionally, cabling must satisfy requirements defined in the manuals of connected field devices, in particular if the field device is certified for use in a hazardous location.
- 11) All signal cables and interconnections must be shielded and the shields terminated only at the unified earth (ground) bus bar situated inside the enclosure
- 12) All conduits and cable armour shall be bonded to protective earth (ground), and care must be taken to avoid ground loops and to avoid contact with cable shielding.
- 13) Cable entry glands, blanking plugs, reducers, adaptors and breather devices must be suitably approved and must not reduce the IP rating or protection levels. Items should not be used if there is a high risk of mechanical damage to the equipment or enclosure.
- 14) Access doors and entry points must be kept closed when the system is energised in normal operation.
- 15) Enclosure locking handle security screws must be fully tightened during normal operation.
- 16) All equipment in this manual is rated to +2000 m (6562 ft) altitude maximum.
- 17) For safety reasons this equipment must be operated by qualified personnel only. Read and understand the Instruction Manual completely before operating or servicing the equipment.
- 18) Touchpoint Plus Wireless systems may contain hazardous live terminals. Appropriate precautions should be taken during operation, installation, and maintenance and servicing. Specifically, operators must have appropriate training and experience to be aware of the hazards to which they may be exposed, and of measures to minimise risk to themselves or other people.
- 19) The protection provided by the equipment may be impaired if the equipment is used in a manner not specified or authorised by the manufacturer.
- 20) Be aware that extended exposure of a detector element to certain concentrations of combustible gases and air can introduce stress to the element that may seriously affect its performance, and therefore recalibration should be carried out or the sensor replaced, or both, after an alarm due to an indication of a high concentration.
- 21) When used in a Gas Detection summing up role, the gas reading may be higher than the actual concentration

Important Safety Information

1.1 Cautions

- 1) Touchpoint Plus Wireless SMPS and Input / Output Modules have no user serviceable parts. In the unlikely event of a failure, the item must be replaced using only manufacturer supplied parts.
- 2) Do not use sharp objects to operate the touchscreen as this could irreparably damage the User Interface and adversely affect its IP rating.
- 3) Use only soft, damp cloths or screen wipes to clean the Touchpoint Plus Wireless. Do not use solvents or abrasives as they will damage the User Interface.
- 4) Once commissioned, Touchpoint Plus Wireless is intended for continuous operation.
- 5) Undo the security screws before pulling the locking handle. Failing to do so may irreparably damage the enclosure.

1.1.1 Intended Readers

This Manual should be read by everyone who operates or monitors the Touchpoint Plus Wireless gas detection system.

Only personnel who have been fully trained by Honeywell are authorised to Install, Set-up, Service, and Test, Repair, or Recondition Honeywell gas detection systems.

IMPORTANT

Personnel, who work on, or in the area of, the Touchpoint Plus Wireless Gas detection system must be made aware of the contents of Chapter 1 – Important Safety Information

Before unpacking the system, read the documentation that accompanies it.

1.1.2 Conventions Used

The following conventions are used in this manual:

'Start up' refers to the action of switching on the system ready for use.

'Restart' refers to cycling the power off and then on again.

'Boot up' refers to the action of starting the software from cold.

'Reboot' refers to shutting down and restarting the software without interrupting the power supply.

'TPPLW' refers to Touchpoint Plus Wireless.

1.1.3 Associated Manuals

This manual should be used in conjunction with any manuals provided with ancillary components and sensors.

Safety Hazards, Warnings And Cautions

Chapter 2 – Safety Hazards, Warnings and Cautions

2.1 Safety

Incorrect set-up, maintenance, operation or modification of the Touchpoint Plus Wireless gas detection system *or its installation* may constitute a serious hazard to the health and safety of personnel and their environment. It is therefore imperative that the contents of this chapter are thoroughly understood by everyone who has access to the gas detection system or its associated equipment.

This equipment is suitable for use in Class I, Division 2, Groups A, B, C, and D or non-hazardous locations only.

When properly installed, this gas detection system enclosure is rated as IP65.

It may be installed in a Pollution Degree 2 (i.e. laboratory, office or control room) or Pollution Degree 3 (i.e. unheated boiler room) environment as defined by IEC/UL/EN 61010–1: Safety requirements for electrical equipment for measurement, control and laboratory use.

In all cases, several hazards may be present when operating or servicing the equipment and extreme caution must be exercised at all times. The hazards that may be encountered include:

- Class 1 electrical hazards (AC 110/220 V, DC 18–32 V)
- Mechanical hazards (Heavy components, swinging access doors)
- Environmental hazards (toxic atmospheres)
- Fire and Ignition hazards (Touchpoint Plus Wireless is **not** ATEX/IECEx Zone 1 certified, and cannot be used in flammable atmospheres, or where oxygen concentrations >25% v/v O₂)

2.1.1 Warnings and Cautions

Safety of this equipment is reinforced by the use of safety labels that are fixed to the equipment in a visible manner. The type of safety labels used and their location is detailed in this chapter. The degree of seriousness of the hazard is indicated in this manual by the use of the following signal words accompanied by a suitable hazard symbol:

DANGER

Indicates an imminent hazard that, if not avoided, is **extremely likely to result** in death or serious injury.

WARNING

Indicates a potentially hazardous situation that, if not avoided, **could result** in death or serious injury.

CAUTION

Indicates a potentially hazardous situation that, if not avoided, **may result** in minor or moderate injury. It is also used to alert the user against unsafe working practices and potential damage to equipment.

Safety Hazards, Warnings And Cautions

2.1.2 Safety Hazards

The following specific hazards are associated with the installation and use of this equipment:

DANGER – IGNITION HAZARD

Touchpoint Plus Wireless is **not** ATEX/IECEX certified, and it may only be installed in safe areas where there are no flammable atmospheres, and no oxygen concentrations >25% v/v O₂.

WARNING – LETHAL VOLTAGE PRESENT

All power supplies must be hard wired and must include a circuit breaker (RCD / RCCB) and, close by and unobstructed, a means of manually isolating and locking-out the power supply without breaking the protective earth (ground) connection.

Removable plug/socket connection is not permitted under any circumstance.

WARNING – LETHAL VOLTAGE PRESENT

Lethal current may be present in this equipment when electrical power is applied. There is a danger of death or injury from electrical shock. Isolate power before opening electrical access panels. Ensure residual current is fully discharged before touching live terminals.

WARNING – LETHAL VOLTAGE PRESENT

Lethal current may be generated both internally and externally to the system. All installations, including enclosure, external units, must be grounded to protective earth, and must be capable of staying earthed (grounded) when the power supply is interrupted.

The Protective Earth (Ground) symbol is shown to the left, and always has a green background. Do not confuse it with the chassis earth symbols shown below it.

WARNING – TOXIC WASTE AND HARMFUL BY-PRODUCTS

The Touchpoint Plus system and/or its sensors may become contaminated by the ambient environment in which it or they are used. It is the Customer's sole responsibility to ensure that all appropriate safety precautions are taken before handling any components or transferring them to any other party.

Safety Hazards, Warnings And Cautions

2.1.2 Safety Hazards (Cont.)

The following general hazards are associated with the use of this equipment:

WARNING – FIRE OR EXPLOSION HAZARD

Battery may explode if mistreated. Do not disassemble or dispose of in fire.

WARNING – DO NOT USE WATER

DO NOT USE WATER if a lithium battery overheats or burns, as this may make the fire worse and may cause an explosion.

Evacuate the area and call Emergency Services.

CAUTION – HEALTH AND ENVIRONMENTAL HAZARDS

This equipment contains a number of potentially toxic substances that may pose a health or environmental hazard if exposed to very high temperatures, VOCs or corrosives, or if improperly handled or carelessly disposed of.

CAUTION – RISK OF INJURY AND DAMAGE

Each Touchpoint Plus enclosure is heavy and weighs considerably more when packed. Ensure that a Manual Handling Risk Assessment is carried out before moving or installing the system, and ensure that the enclosure is fitted securely to a suitable surface.

CAUTION – RISK OF EYE INJURY

Touchpoint Plus uses high energy AC and DC currents that may cause arcing and sparks if shorted out. Always wear eye protection when the enclosure is open.

CAUTION – RISK OF HEARING DAMAGE

Touchpoint Plus can be used to control loud alarms and sirens. Always wear hearing protection when working in the vicinity of loud noises.

Safety Hazards, Warnings And Cautions

2.2 Location and Description of Warning Labels

2.2.1 Safety Warning Labels

In accordance with the requirements of the European Standard EN 60825–1, appropriate warning labels are mounted in specified locations on the equipment. This is to indicate conditions under which the user could be subjected to electrical hazards.

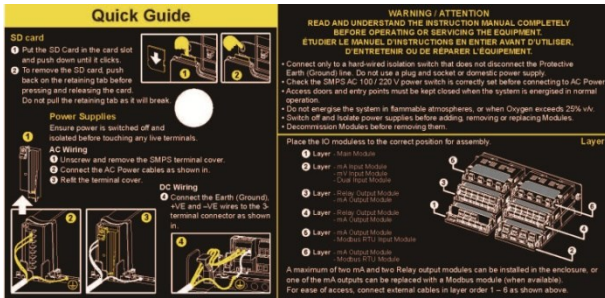

Figure 1. Quickstart Guide Label (Not to Scale)

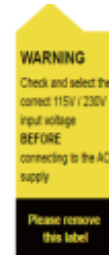

Figure 2. SMPS Voltage Warning Label (Removed During Installation)



Figure 3. Protective Earth (Ground) Point



Figure 4. Equipment Earth (Ground) Point

This Protective Earth (Ground) location point label is used inside the system and is not normally visible to the operator.

This Equipment Earth (Ground) location point label is used inside the system and is not normally visible to the operator.

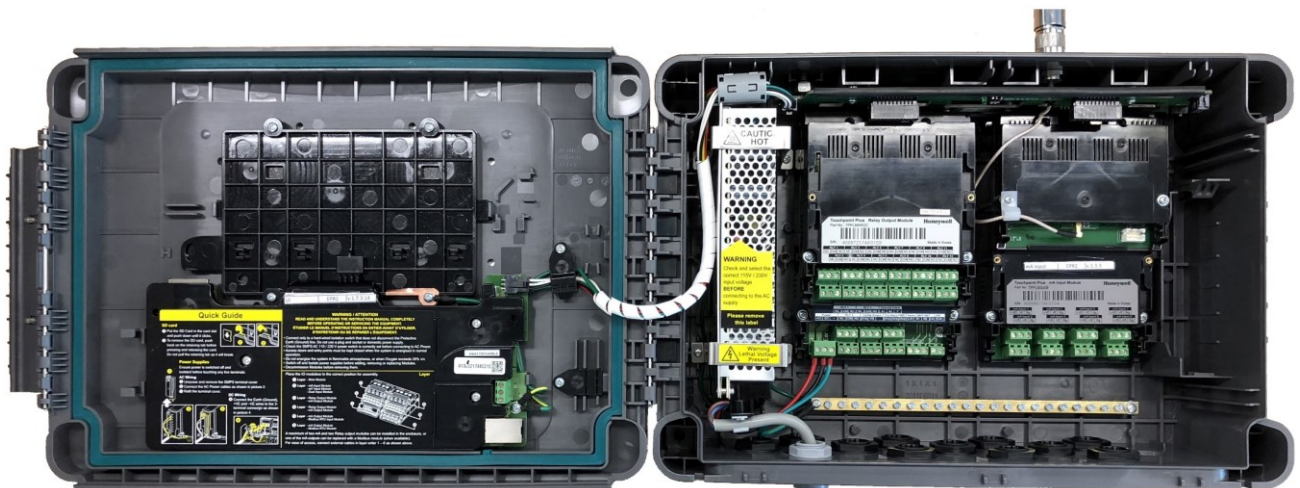

Figure 5. Internal Label Positions

Safety Hazards, Warnings And Cautions

2.3 Electrical Hazards

Gas detection systems contain electrical supplies that are potentially dangerous and hence precautions must be taken to prevent the risk of electrocution.

2.3.1 General Precautions

- Read the relevant manual before beginning any operating or service procedures.
- Only personnel trained and certified by Honeywell are authorised to service, fit or remove internal parts.
- Only the minimum number of trained personnel, consistent with safety, should have access to the area while work is being carried out. If necessary, erect warning signs and barriers.
- Follow accepted working procedures and codes of practice as well as the electrical safety code for the site where the equipment is installed.
- Never operate the equipment under normal conditions with access panels removed or shorting links fitted.
- Do not 'Live Test' without a Safe System of Work (SSoW).
- Always keep the area around the equipment dry and free of obstructions.
- Switch off and Isolate the equipment if water ingress is suspected or confirmed.
- Never operate the equipment if any Mains power cable is frayed or damaged.
- Never wear wristwatches, rings, bracelets, or other jewellery when working around electrical circuits or moving parts.
- Take anti-static precautions when working on electronic circuits.
- Never work on electrical equipment alone.

2.3.2 Component Testing and Replacement

Before carrying out any electrical testing or component replacement:

- Read this Manual to become familiar with the location of high voltage components.
- Isolate the system at the main circuit breaker, lock it in the 'Off' position, and attach a notice indicating that maintenance work is in progress.
- Always wait for 5 minutes after isolating the equipment to ensure that stored energy has dissipated.
- Never assume the polarity of cabling or replacement components. Refer to electrical schematics or contact Honeywell for confirmation.
- Use only Honeywell approved replacement parts.

WARNING – UNAUTHORISED PERSONNEL

Only Honeywell trained and certified maintenance technicians are authorised to carry out component testing and replacement. Unauthorised work may result in a potentially dangerous situation and will invalidate the manufacturer's warranty.

ANTI-STATIC PRECAUTIONS

Antistatic Precautions are required to prevent severe damage to electronic components.

Safety Hazards, Warnings And Cautions

2.3.3 Antistatic Precautions

As with all modern electronic circuits, the Printed Circuit Boards (PCBs) in Touchpoint Plus Wireless systems utilise some static-sensitive components that can be severely damaged if subjected to static discharge. Static can be generated on the human body by friction or movement and is discharged through the first contacted route to earth. It can also jump gaps between items of differing electrical potential.

Static damage is not always immediately apparent and can cause component failure at any time after the static discharge has occurred. It is, therefore, very important that everyone takes the following precautions when handling PCBs:

- An industry approved antistatic wrist strap, containing a resistive component greater than 1Megaohm, must be worn and connected to an effective earth (ground) point. The continuity between the strap and earth (ground) must be checked regularly.
- PCBs must only be handled by their non-conductive edges. Do not allow any components, conductive tracks or contacts to come into proximity with the body, clothing, machinery, power source or any material other than a static-dissipative mat.
- With the exception of assemblies containing batteries, anti-static packaging must be used for transporting PCBs and Integrated Circuits (ICs). All Touchpoint Plus Wireless electronic components are shipped in appropriate packaging that can be re-used when returning items for test or repair.
- Avoid wearing clothing manufactured from, or containing a high proportion of, man-made fibres. These can build up a high static potential that may not be discharged through the body or wrist strap.

An effective earth (ground) point is the protective earth (ground) bus bar inside the enclosure. This can be used to connect a suitable anti-static wrist strap provided that the Gas detection system is connected to protective earth (ground) via the mains power supply cable.

IMPORTANT

If installed correctly, the equipment earth (ground) point is connected directly to mains earth (ground) via protective earth and the mains power supply cable. It is not dependent on the position of the Isolator switch or circuit breaker.

2.3.4 Good Practice

After switching off the system, it is good practice to wait at least 15 seconds before switching it on again. This allows the circuits and RAM to discharge adequately before being powered-up again. Failing to do so may cause data corruption.

2.3.5 Lithium Battery Hazard

Lithium batteries are fitted to Touchpoint Plus Wireless as backup power sources.

Replace the battery pack with Honeywell Analytics part no. TPPL0IBB (order number: TPPLSIBB) and the PCB coin battery with type CR2032 only.

Use of other batteries may present a risk of fire or explosion.

LITHIUM BATTERY TOXIC AND FIRE HAZARDS

Lithium batteries may cause severe injury or death if ingested, and may catch fire or explode if mishandled, recharged, burned or disposed of incorrectly.

Always handle lithium batteries with care, keep them out of the reach of children, and dispose of them carefully in accordance with local regulations.

Safety Hazards, Warnings And Cautions

2.4 Product Compliance

This product complies with the following standards and directives.

Other safety directives may apply to the complete system installation if an OEM's product is integrated into other equipment or machinery.

Title	Standards	Certificates
Ingression protection	IP65	
Hazardous Locations (Non-Incendive)	Class 1, Division 2, Group A, B, C, D, Temp. Code T4 UL 121201, CAN/CSA C22.2 No. 213-17	UL File E480011
Electrical Safety	UL/IEC/EN 61010-1 CSA C22.2 No.61010-1-12/No.142, and UL 508	UL File E466771, E470577 and E480011
EMC/RFI	EMC Directive (EN 50270:2015)	
Battery Pack	UN 38.3 (IEC 62133), UL 2054, UL 60950-1 and CSA C22.2 No.60950-1-07	UL File MH60522
Low Voltage Directive	IEC/EN 61010-1 (3rd Edition)	
Wireless	FCC 15C, IC RSS-247 2.4 GHz and sub 1 GHz	
Performance	CSA 22.2 No. 152-M1984	UL File E480011

Note: FA324 is not available in Class 1 Division 2.

Note: The Equipment referred to in this manual contains components and assemblies that are each certified for use in a variety of differing environments, and it is the site owner's responsibility to confirm the suitability of the equipment prior to its installation and use.

Check the product rating plate and look for the following marks to ensure that the supplied equipment is suitable for its intended location and purpose:



Products bearing the CE mark conform to all applicable European Directives as stated on the Honeywell product specific EC Declaration of Conformity.



Products bearing the UL mark conform to the requirements for Ordinary Locations. The letters C and US mean that the product is certified for use in Canada and the United States of America.

IMPORTANT

Read and understand the instruction manual before operating or servicing the equipment.

Safety Hazards, Warnings And Cautions

2.5 Conditions of Use

This Touchpoint Plus Wireless equipment should only be operated under the following circumstances:

- By properly trained personnel.
- Under approved conditions.
- With due authorisation.
- Using approved maintenance and servicing procedures.

2.5.1 Training of Personnel

Honeywell and / or its distributors can provide training for operators and maintenance personnel. Personnel who have been trained in operation and maintenance shall be limited to carrying out only those procedures and tasks taught during the training course. Honeywell certified maintenance technicians must carry out all other tasks.

Honeywell can also provide additional or advanced training. Retraining is recommended periodically and whenever equipment is upgraded.

2.5.2 Conditions Satisfying Local, National and International Safety Regulations

Approved conditions must satisfy the requirements of applicable national and international safety standards and statutory requirements relating to electrical, EMC, and health hazards. In addition, they must satisfy the requirements of the Site Safety Officer and the local safety regulations.

2.5.3 Due Authorisation

Before any production, maintenance, or servicing procedure is carried out; written authorisation must be obtained from one of the following personnel to confirm that the proposed task satisfies the necessary safety conditions:

- A competent authorised person having a professional qualification in an appropriate technical discipline.
- The Factory, Technical or Engineering Manager responsible for the working area.
- The Site Safety Officer or an authorised Honeywell representative or approved distributor.

2.5.4 Approved Maintenance and Servicing Procedures

Approved Maintenance and Servicing Procedures are those stipulated in this manual or as authorised separately by Honeywell.

It may be necessary to establish a temporary Locally Controlled Area (LCA) to restrict access during maintenance, testing or service of this equipment.

2.6 Security Guide

Establishing an Ethernet connection to Touchpoint Plus Wireless may expose the system to vulnerabilities. Honeywell recommends against connecting Touchpoint Plus Wireless to untrusted computers or equipment without taking appropriate measures to ensure security.

System General Description

Chapter 3 – System General Description



Figure 6. Touchpoint Plus Wireless Wall-Mounted Controller

The Touchpoint Plus Wireless is an entry level (or upgrade) touch-screen digital Controller for general industrial and commercial gas detection systems hybrid wireless gas detection systems. It has eight wired and 64 wireless input channels.

It can handle 4-20 milliamp analogue inputs and wireless gas detectors, and it can control various outputs such as audible and visible signals and solenoid valves.

The cabinets are constructed from high-impact plastic and have fully-sealed, easy opening access. They are supplied with a wall mounting or can be directly mounted to any solid vertical surface or rack. Cable entry is via entry glands on the lower side.

Touchpoint Plus Wireless is rated IP65, which means that it is dustproof and can be subjected to low-pressure water without significant ingress. This makes it particularly suited to offices, control rooms and unheated boiler rooms.

System General Description

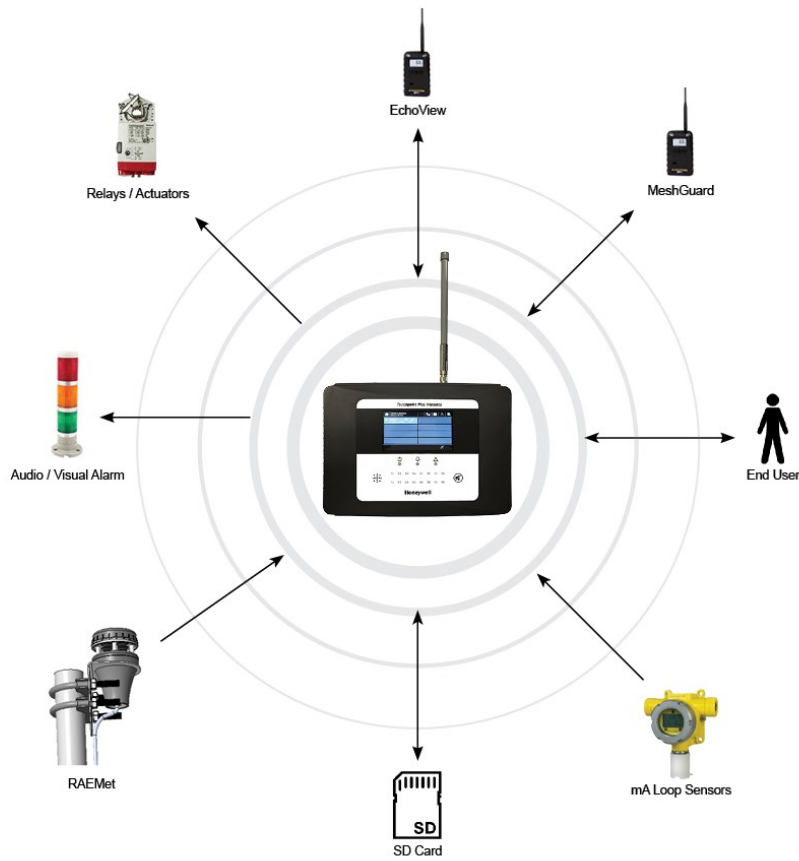

Figure 7. Typical Installation Options

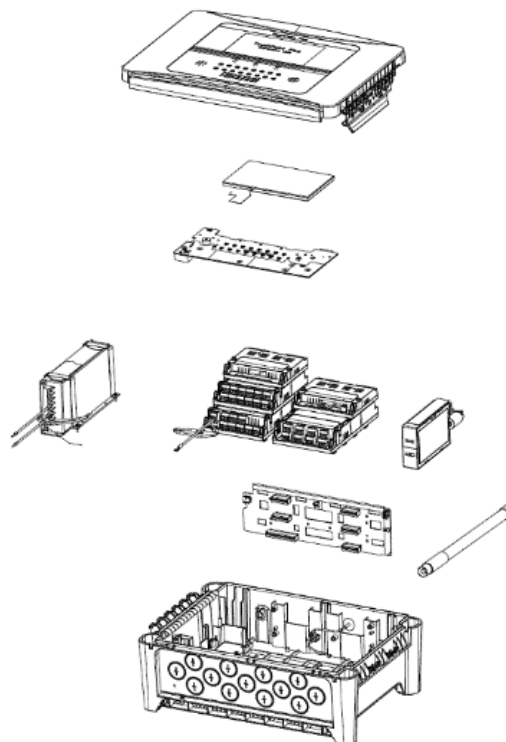

Figure 8. Controller Exploded View

System General Description

Other features:

- Colour LCD Touch Screen with multi-language GUI and menus
- Password protection
- Flexible Mains Power Input: 50 – 60 Hz 110/220V ~ (AC), 18 – 32V $\overline{\text{DC}}$ (DC), Max 105W
- Up to 8 channels of Analogue Input (0–22mA)
- 2 or 3-wire signal inputs
- Up to 14 channels of user configurable relay controlled Output
- Alarm update on Acknowledge
- Automatic Self-Diagnostic with error codes
- Event recording
- SD Card

3.1 Equipment Specification

3.1.1 Power Requirements

The Touchpoint Plus Wireless system is designed to operate on a single phase, 50 to 60 Hz, 110/220 V~(AC) supply with a typical power consumption of less than 105 W.

Alternatively it can be connected to a 18–32V $\overline{\text{DC}}$ (DC) supply with a typical power consumption less than 105W

The system can contain an optional backup battery to guard against short-term power disruption.

Nr.	Power Usage	Module Qty	Power	Total Power (Max) W	Remarks
				mA in	
1	UI Module	1	3.4	3.4	
2	Main Module	1	1.0	1.0	
3	mA Input Module	1	0.3	0.3	8 ch, Not including Field Device power
	mA Field Devices	-	40	40	Field Device power (8 ch* 5W)
	WIO module	1	1.2	1.2	
5	Relay Output Module	1	2.5	2.5	
6	Charging power for backup battery pack	1	6	6	
7	Audio/Visual Alarm	-	28.8	28.8	When alarm devices are connected
8	SMPS Power Loss	-	14.0	14.0	
MAXIMUM CONSUMPTION				97	

Table 1. System Power Calculations

System General Description

Input	Voltage Range AC	AC 110/220 V manually switchable 300 VAC surge for 5 sec without damage
	AC Frequency Range	50 – 60 Hz ± 6%
Output	DC Voltage	24 V
	Rated Current	6.5 A
	Current Range	0 – 6.5 A
	Rated Power	156 W
Protection	Overload	110 – 150 % rated output power
	Over-Volt	27.6 – 32.4 VDC Hiccup mode, which recovers automatically when the fault is removed.

Table 2. Power Supply (SMPS RS–150–24) Electrical Ratings

3.1.2 Weights

	TPPLW basic unit	Remark
System alone	8.5 Kg (18.7 lbs)	
System with packaging	9 Kg (20 lbs)	

Table 3. System Weights

Note: One input module, one relays, one WIO module, AC power and backup battery based for basic

3.1.3 Dimensions

External Dimension	Millimetres	Inches
Depth	156	6.2
Length	426	16.9
Width	300	11.8

Table 4. System Dimensions

3.1.4 Ambient Operating Temperature

–10 °C to +55 °C (14 °F to 131 °F) Certified range

3.1.5 Overall Ambient Operating Humidity

5 % to 95 %RH, non-condensing

3.1.6 Storage Conditions (Without batteries)

–25 °C to +60 °C (–13 °F to 140 °F), @ 5 % to 95 %RH, non-condensing

3.1.7 Storage Conditions (With batteries)

1 year: –20 °C to +25 °C (–4 °F to +077 °F)
 3 months: –20 °C to +45 °C (–4 °F to +113 °F)
 1 month: –20 °C to +60 °C (–4 °F to +140 °F)

3.1.8 IP Rating

The system is sealed to IP65 when appropriate cable entry glands are used.

System General Description

3.1.9 Construction

The system cabinets are constructed from PC ABS plastic with a secured quick release front access door panel.

The Controller door panel holds a touch sensitive colour LCD with a membrane cover over additional buttons, LEDs and an audible warning horn.

Inside the Controller cabinet is a Switched-Mode Power Supply (SMPS) providing a nominal DC 24 V output, an optional Lithium-ion backup battery, a Main Module, a mA Input Module, one Relay Modules, protection fuses, and the control and user interface electronics.

Both cabinets contain a common Earth (ground) rail that must be bonded to Protective Earth (Ground) through an isolation switch that does not disconnect the Earth line.

3.1.10 Touchpoint Plus Wireless Packaging

- Touchpoint Plus Wireless outer packaging is made from cardboard. Facilities for recycling are widely available.
- Touchpoint Plus Wireless inner packaging is made from Stratocell®, Low-Density Polyethylene (LDPE) foam. The foam can be recycled into new Stratocell® where such recycling facilities exist.
-

3.1.11 Packaging Components for Return to Manufacturer

Honeywell is unable to accept any consignment that does not conform to the European Classification, Labelling and Packaging (CLP) Regulations (EC) 1272/2008.

Consult your distributor, supplier, or the manufacturer if you require further advice.

3.1.12 Disposal (WEEE Directive)



The system contains Lithium batteries and a number of homogenous hazardous materials. These should be disposed of carefully in accordance with the WEEE Directive and local laws and guidelines. Under no circumstances can they be disposed of as domestic waste.

System General Description

3.2 System Construction

This figure shows the basic building blocks of the Touchpoint Plus Wireless system.

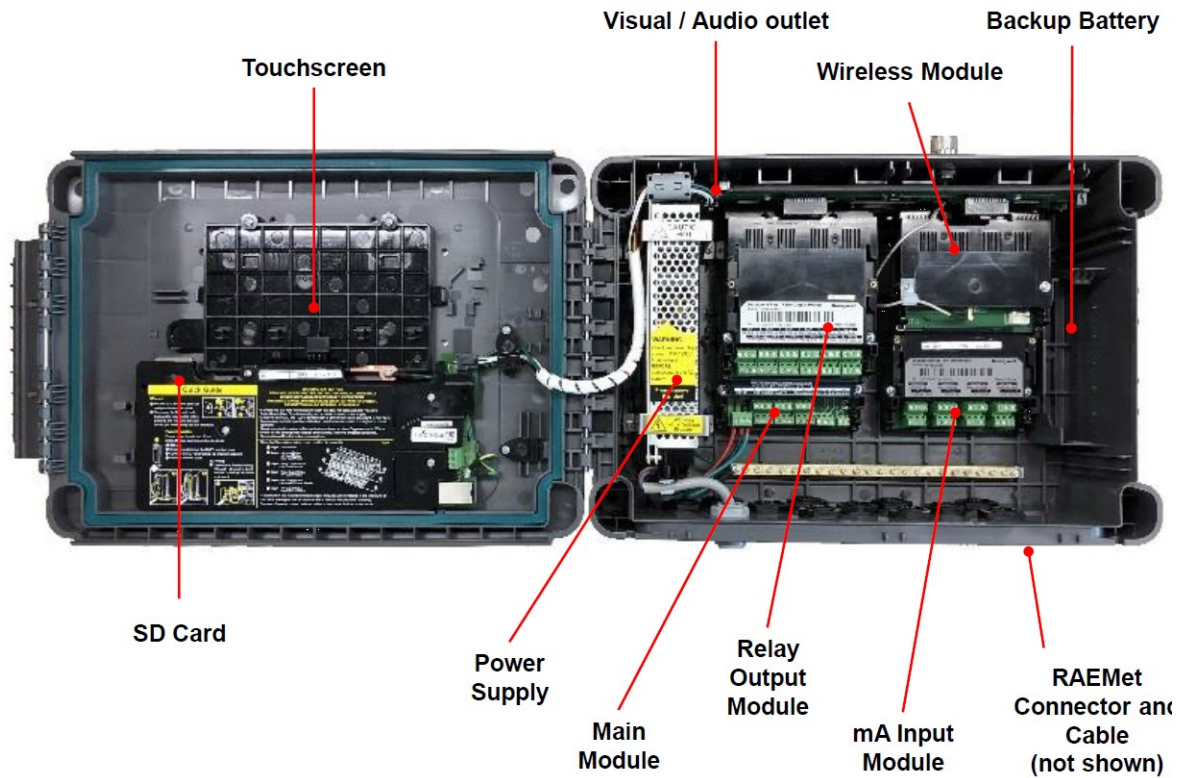

Figure 9. System Layout Before Installation

System Mechanical Installation

Chapter 4 – System Mechanical Installation

The system can be directly wall-mounted, mounted on an optional mounting fixture. Whichever method is chosen, the mounting must be sound, secure, and capable of supporting the weight of the enclosure plus the weight of any cables and glands.

When choosing a location, it must be easily visible and accessible, with room to mount an external power isolator. There must also be room to fully open the access door, which opens to the left, and room to easily access the door locking handle and its securing screws, which are situated on the right.

The units should be mounted so that the screen can be easily accessed and seen, but they should not obstruct accesses, walkways or exits.

Although the units are IP65 when installed correctly, they should be mounted away from heat sources, out of direct sunshine, and should be protected from rain, severe weather, steam or excess humidity and condensation.

These units have only passive cooling, so an adequate airflow must be maintained to prevent overheating.

Assembly	IP	Pollution Degree	Remarks
Wall mounted cabinet	65	2	When properly installed using the appropriate cable entry glands

CAUTION

It is the Customer's responsibility to ensure that the equipment is correctly installed, and that cable entry glands or blanks of the appropriate IP rating are correctly used.

Failure to do so will invalidate the quoted IP / NEMA / Pollution ratings and may invalidate the warranty.

CAUTION

The units as supplied have two hex-socket securing screws in the access door handle, and these have to be undone prior to opening the handle. Failing to do so could cause irreparable damage to the housing.

The handle must be correctly locked and the screws must be correctly tightened when the unit is in operation. Failing to fully secure the enclosure is unsafe and will invalidate product certification.

System Mechanical Installation

4.1 How to Open and Close the Enclosure

- 1) Ensure that it is safe to open the enclosure and, if necessary switch off and isolate electrical power.
- 2) Unscrew the two 3mm Hex socket security screws (1) until they become loose (2).
- 3) With a gloved hand only, pull the handle until it comes free (3). Do not apply undue force.
- 4) Open the enclosure door fully.



Figure 10. Undoing the Security Screws and Opening the Enclosure

- 5) Closure is the reverse of this procedure, but care must be taken not to exert undue force, and **do not** press on the membrane or touch screen areas.

Note: The door recess has an environmental seal that requires some pressure to close the door correctly. The enclosure handle is the primary method of applying this pressure but you can assist it by pressing on the door edge directly above the handle as you press on the handle itself.

System Mechanical Installation

4.2 Wall Mounting Requirements

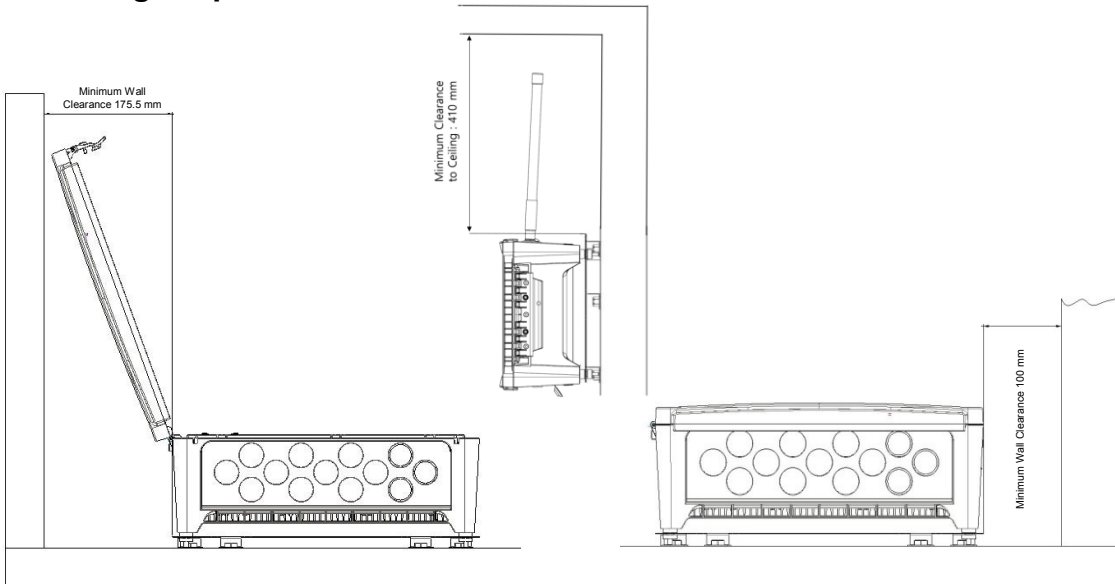

Figure 11. Installation Clearance Measurements

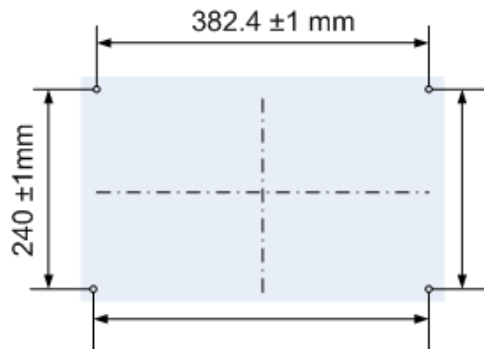

Figure 12. Wall Mounting Points

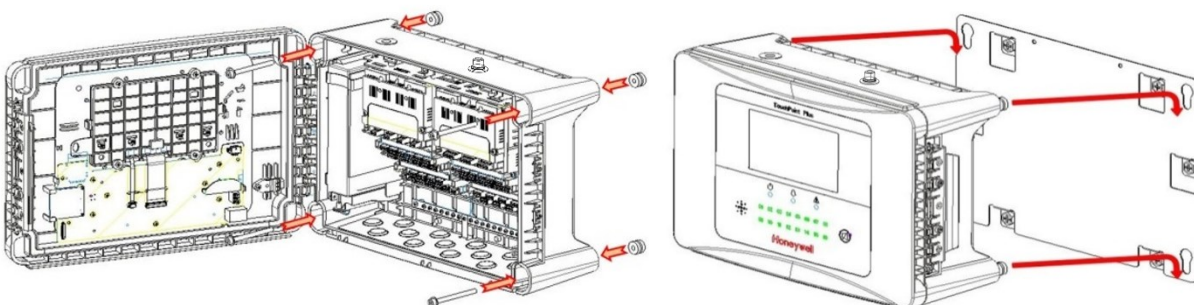

Figure 13. Wall Mounting Plate Option

You can use the wall mounting plate as a template and location guide, and you should ensure that the mounting bolts are adjusted to fit the plate bayonet holes before fixing the plate to the wall.

System Mechanical Installation

4.2.1 Wall Mount Fixings

You will require the following locally sourced items to install the Touchpoint Plus Wireless:

Tool to undo the enclosure access handle security screws:

- 3 mm Hex key

Suggested Fixings to screw the enclosure to the wall only:

- Screw Max. Dia: 6.4 mm (#14) dome or cheese head screw
- Screw Min. Length: 76 mm (3 in.) – Normal fix
- Washer Max. Dia: 14.3 mm (0.56 in.)

Note: The sizes above are given to allow for clearance in TPPLW Enclosure. The actual length and type of fixing should be determined by the surface material and the type of anchor required.

Suggested Fixings for using the Mounting Plate:

For the plate, choose fixings appropriate to the surface and the weight of the enclosure plus cables. You will also need to use suitable bolts, washers and lock nuts (see diagram below).

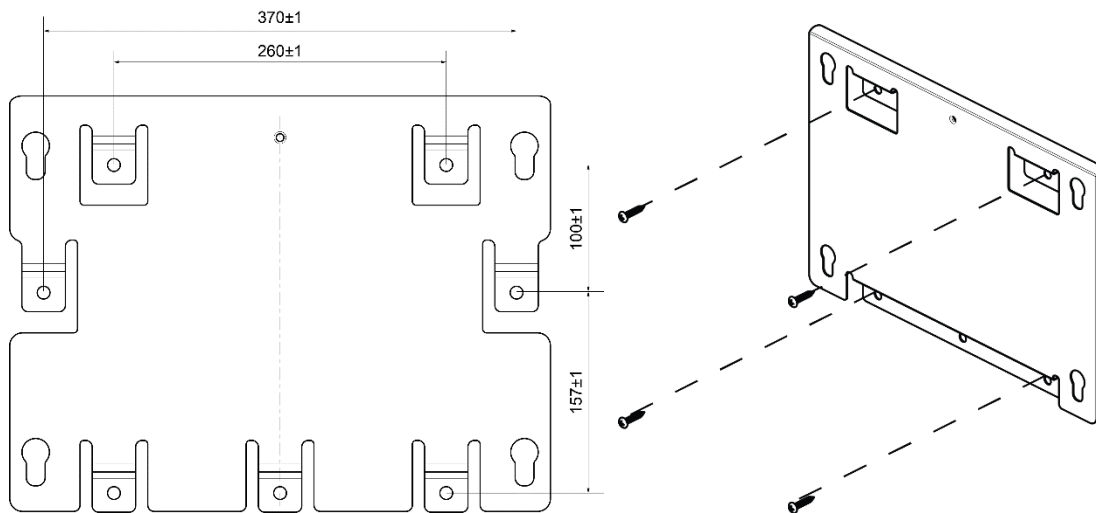

System Mechanical Installation

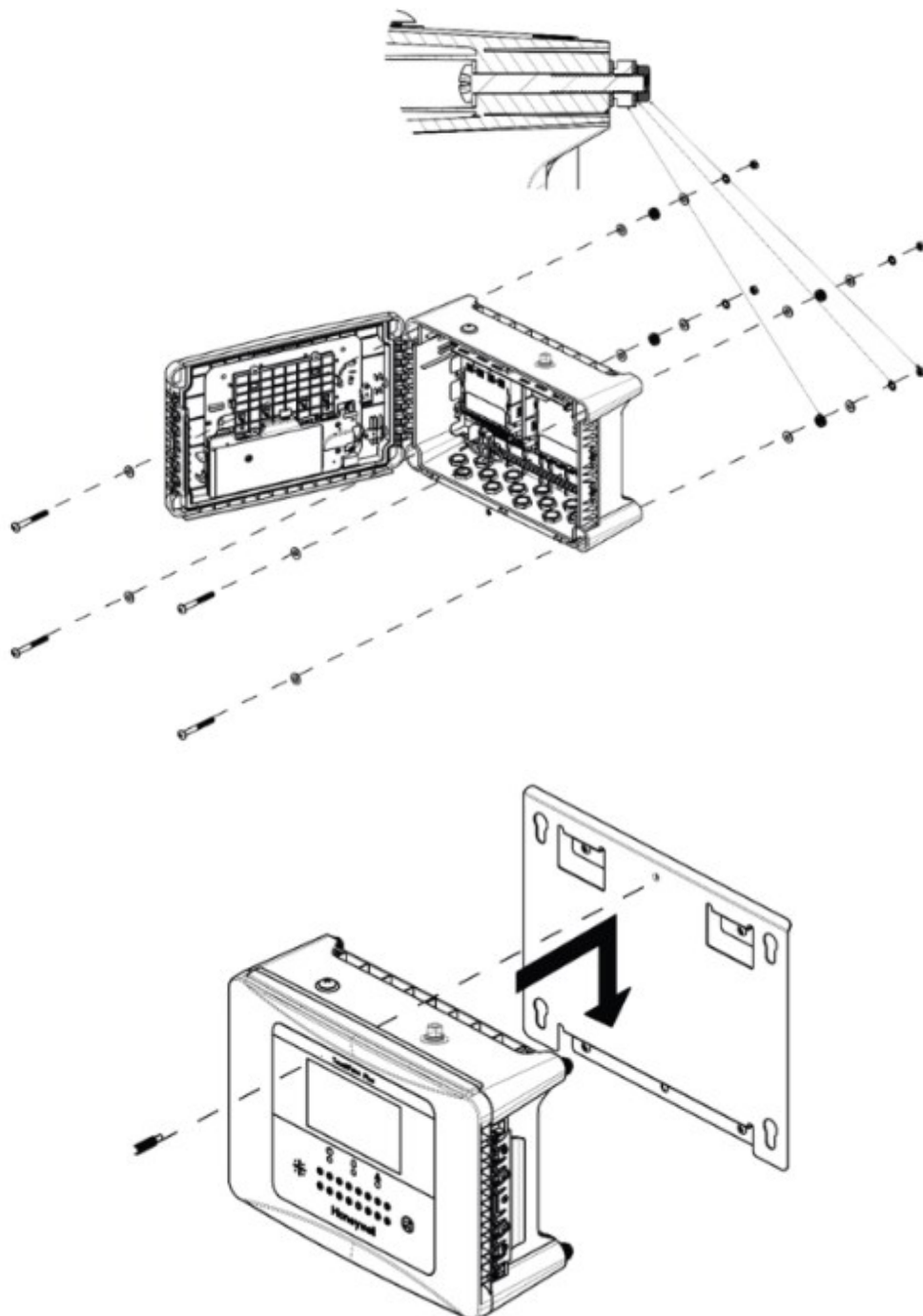

Figure 14. Fixing Orientation When Using the Optional Mounting Plate

Note: You should ensure that washers between TPPLW enclosure and the wall or mounting plate are sufficiently large to spread the load evenly.

- For metal conduit, use a metal ground plate (i.e. PN: TPPLMGND).
- For external visual/audio outlet, ensure IP65 is maintained (i.e. PN: M-700123).
- For cable gland, use type PG16 and tighten to 44.2 lb-in (5 N-m) torque.
- For antenna extension, use 10 m antenna extension cable (PN: TPPLWOCBL).
- For lightning surge protection, install a coaxial lightning surge protector inline between the antenna and TPPLW. Refer to Ch.5.2.6 Grounding for detailed information.

Electrical Power And Interfacing

Chapter 5 – Electrical Power Connection and Interfacing

WARNING – ELECTRICAL SHOCK HAZARD

All power supplies must be hard wired and must include a circuit breaker (RCD / RCCB), and (close by and unobstructed) a means of manually isolating and locking out the power supply without breaking the protective earth (ground) connection.

Removable plug and socket connection is not permitted under any circumstance.

WARNING – ELECTRICAL SHOCK HAZARD

Lethal current may be present in this equipment when electrical power is applied. There is a danger of death or injury from electrical shock. Isolate power before opening electrical access panels. Ensure residual current is fully discharged before touching live terminals.

WARNING – ELECTRICAL SHOCK HAZARD

Lethal current may be generated both internally and externally to the system. All installations, including remote units and cables, must be connected to protective earth, and must be capable of remaining so when the power supply is interrupted.

Protective earth is shown by the green symbol on the left.

WARNING

Honeywell can accept no responsibility for any damage or injury caused by incorrect or faulty wiring.

5.1 Power Connection

The TPPLW systems are factory set to operate at a manually switchable voltage of AC 110/220 V on single phase, 50 to 60 Hz supplies. They can also be connected to DC 18 – 32 V SELV without backup battery or DC 24 – 32 V SELV if using the backup battery option.

All systems have a typical peak power consumption of less than 105 W, and must be directly connected to supplies via a Main Isolator Switch that leaves protective earth (ground) permanently connected. The circuit should incorporate a Residual Current Device or Residual Current Circuit Breaker (RCD or RCCB).

TPPLW systems are not certified for connection to domestic power supplies.

WARNING

The system is normally supplied with the voltage pre-set to the customer's specification. If the supplied voltage is incorrect, it must be altered prior to connecting to the mains power supply.

It's customer's responsibility to provide appropriate power supply to detectors and controller.

Electrical Power And Interfacing

5.1.1 AC Power Supply

To confirm or alter the pre-set operating voltage, open the system front cover, locate the SMPS transformer on the left side and, if required, change the voltage selector using a screwdriver at the point shown by the yellow and black label below:

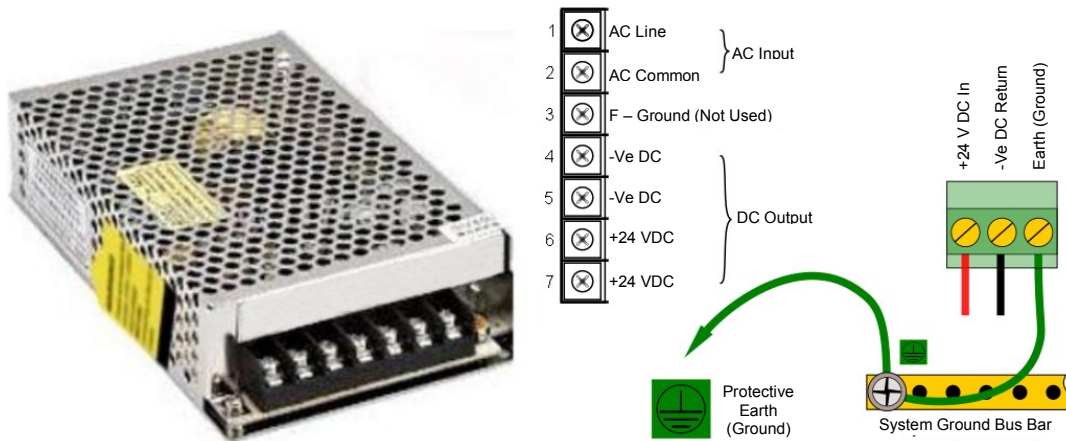

Note: Mains Earth (Ground) must only be connected to the protective earth (ground) rail, and not to the SMPS.

Regional power cable wires are coloured in accordance with the following code:

Wire	Europe	USA	CAN	India/Pakistan
Protective Earth (Ground)	Green + Yellow	Green	Green	Green
Isolated Earth (Ground)	—	Green + Yellow	Green	—
Neutral	Blue	White	White	Black
Line	Brown	Blue, Red, or Black	Red or Black	Red, Yellow, or Blue

Table 5. Regional Power Cable Colours

Before making any electrical connections or changes ensure that:

- the mains supply isolator switch is in the **Off** position
- the system is set up to operate at the correct voltage

Refer to Ch.3.1.1 Power Requirements for further information on system electrical specifications and power requirements.

Note 1: Input voltage of less than DC 23.5 V will fail to charge the backup battery, and it will cause battery unchargeable warning.

Note 2: Field detectors may need their own power supplies if they exceed 15 W per channel to a combined total of 40 W. Refer to Ch.5.2.5 mA Input Module Connections.

Electrical Power And Interfacing

5.1.2 DC Power Supply

It is possible to power the Touchpoint Plus Wireless controller directly from a DC 18 – 32 V supply without using AC supplies at all. However, batteries alone may quickly drop below the minimum DC 18 V requirement when under load.

Note: The system must still be connected to protective earth (ground) when using an external DC supply.

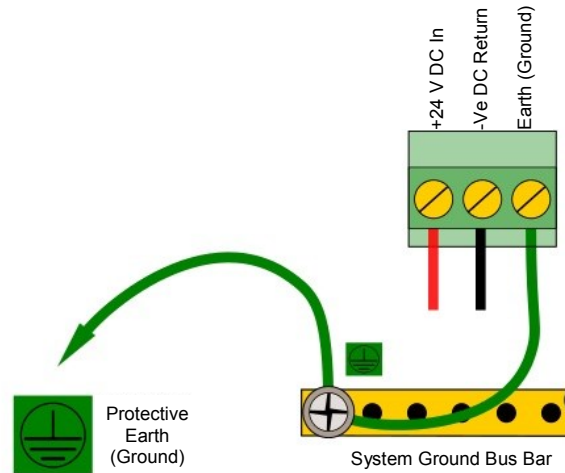

Figure 16. Connections for DC 24 V Supply

5.1.3 Backup Battery Pack

The Touchpoint Plus Wireless can have an optional rechargeable 24 volt Lithium-Ion Battery Pack. This would normally be charged by the SMPS, but can be charged by a separate DC 23.5 – 32 V supply.

Note: The backup battery requires minimum 24 V input to fully charge, and it has a non-replaceable 15 A over-current protection fuse so do not exceed 32 V, 5 A charging input.

DANGER

In the event of Lithium batteries overheating:
DO NOT USE WATER as this can cause them to burn violently or they may explode.

IMPORTANT

The battery should be charged at **DC 24 – 32 V**. The backup battery will not be fully charged and the backup time will be reduced if the charging supply is <24 V.

Electrical Power And Interfacing

5.2 Cabling Requirements

WARNING

All cabling shall be appropriately rated and approved in accordance with national and local regulations. Additionally, cabling must satisfy the requirements defined in the manuals of connected field devices, particularly if the field device is certified for use in a hazardous location.

Signal cables should be shielded to avoid spurious signals, and shall be bonded to protective earth (Ground). Care must be taken to avoid Ground feedback loops.

5.2.1 AC Mains Voltage Power Cables

Use a properly rated AC power (mains) cable, certified and installed in accordance with local and national regulations. The Touchpoint Plus Wireless terminals will accept only copper wire sizes in the range 0.4 – 4 mm² (solid core), 0.4 – 3 mm² (stranded core), or 22 – 12 AWG (> 80 °C). The mains terminals should be torqued to 11.9 lb-in (1.35 N-m), modules are 4.4 lb-in (0.5 N-m).

5.2.2 DC Power Cables

Use a properly rated DC power (mains) cable, certified and installed in accordance with local and national regulations. The Touchpoint Plus Wireless terminals will accept only copper wire sizes in the range 0.9 – 3.3 mm² (solid core), 0.9 – 3.3 mm² (stranded core), or 18 – 12 AWG (> 80 °C). The mains terminals should be torqued to 4.4 lb-in (0.5 N-m).

5.2.3 Field Device Cables

Field Device cabling (sensors, lights, solenoids, etc.) should be appropriate to the zone classification, and in accordance with the device manufacturer's recommendations. Refer to local and national regulations where appropriate, and to the device user manual.

All sensor field cables must be screened and earthed (grounded) in order to:

- ensure correct operation of the system
- avoid spurious signals
- provide lightning protection
- Meet European Standards for RFI and EMC.

The I/O modules will accept only copper wire sizes to a maximum of 2 mm² or 14 – 30 AWG, with the terminals torqued to 4.4 lb-in (0.5 N-m).

Ensure that the maximum loop resistance is not exceeded, as specified by the device manufacturer.

Ensure that the correct power level is present at the field device, as specified by the device manufacturer, and does not exceed TPPLW supply limit of 15W per channel individually or 40 / 68 W in total. (See the notes under **5.2.5 Main Module Connections** for more details about power consumption and availability.)

I.e. if a device's supply requirement is 24 VDC 0.5 A, then the power requirement is 24 V x 0.5 A (V x I) = 12 W. If you use 240 m of AWG 22 cable (R = 0.05 Ω/m), the power line dissipation is 0.05 Ω/m x 240 m x 0.5² A (R x I²) = 3 W. Therefore the total power requirement is 15 W (12 + 3).

You should also test the cable resistance in situ as its Ω/m will increase in line with T_{amb}.

Electrical Power And Interfacing

5.2.4 Main Module Connections

Input / Output	Field device	Label	Terminal
Power	24 VDC	+DC	1
	GND	-DC	2
	Earth	-	3
Channel Relay 001 (Alarm, Fault, Warning Or Inhibit)	—	NC	4
	—	COM	5
	—	NO	6
Channel Relay 002 (Alarm, Fault, Warning Or Inhibit)	—	NC	7
	—	COM	8
	—	NO	9
System Relay 003 (System Failure)	—	NC	10
	—	COM	11
	—	NO	12
Dedicated Alarms (Max 300 mA per channel)	Visible	+24 VDC	13
		VIS	14
		Unused	15
	Audible 1	A1	16
	Audible 2	A2	17
	Audible 3	F	18
External Alarm Power	—	+24 VDC	19
	—	+24 VDC	20
	—	+24 VDC	21
Remote Inputs (Note 4)	Common	3.3 V	22
	Reset	R1	23
	Inhibit	R2	24

Table 6. Main Module Connections

Note 1: +24 VDC Nominal = Controller Input (18 to 32 VDC) – 1.8 VDC (the max voltage drop in TPPLW)

Note 2: Alarm Terminals 13, 19, 20, and 21 can supply +24 VDC at ≤ 28 W combined but this 28 W can instead be used to increase the power available to field sensors if external audible and visible alarms are not connected.

i.e. the 8 sensor channels would normally have ≤40 W of combined available power, but this can be increased to 68.8 W if terminals 13 – 21 are unused.

Note 3: Supply sensors with external power if more than 40 / 68 W total power is required. (If there is no power consumption at terminal 13 to 21, total 68W can be used to power field detector)

Note 4: R_{loop} resistance for remotes reset/inhibit is 18 ohm. i.e. Using 1 mm² shielded cable can be used for 500 m.

Electrical Power And Interfacing

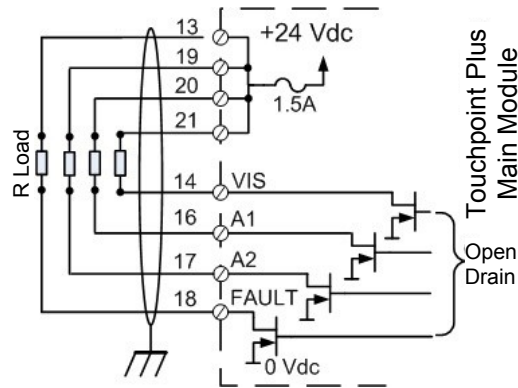

Figure 17. Dedicated Alarm Circuit Connections

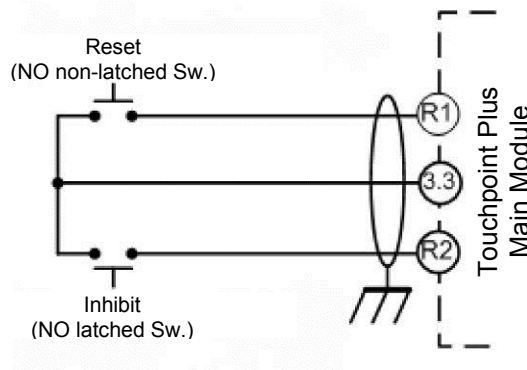

Figure 18. Optional Remote Reset and Inhibit Switch Connections.

IMPORTANT

Remote inhibit and reset switches need protection to protect unauthorized usage because it has engineer level access. It is user responsibility

Electrical Power And Interfacing

5.2.5 mA Input Module Connections

Note: mA input channels are limited to 15 W per channel to a combined total of 40 W (68 W if Main Module Terminals 13 to 21 are not used). Sensors requiring more than 15 W (i.e. IR-F9 (Max 28W) must have their own power supplies.

mA Input Channel	Field device	Label	Terminal
1	+24 VDC	+DC	1
	0 VDC	-DC	2
	4 – 20 mA signal	Sig	3
2	+24 VDC	+DC	4
	0 VDC	-DC	5
	4 – 20 mA signal	Sig	6
3	+24 VDC	+DC	7
	0 VDC	-DC	8
	4 – 20 mA signal	Sig	9
4	+24 VDC	+DC	10
	0 VDC	-DC	11
	4 – 20 mA signal	Sig	12
5	+24 VDC	+DC	13
	0 VDC	-DC	14
	4 – 20 mA signal	Sig	15
6	+24 VDC	+DC	16
	0 VDC	-DC	17
	4 – 20 mA signal	Sig	18
7	+24 VDC	+DC	19
	0 VDC	-DC	20
	4 – 20 mA signal	Sig	21
8	+24 VDC	+DC	22
	0 VDC	-DC	23
	4 – 20 mA signal	Sig	24

Table 7. mA Input Module Connections

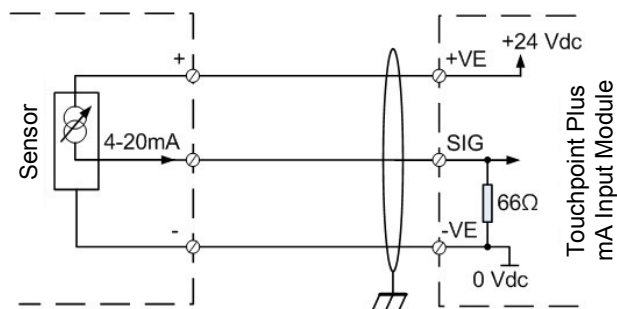

Figure 19. Three Wire Device Powered by a mA Input Module

Electrical Power And Interfacing

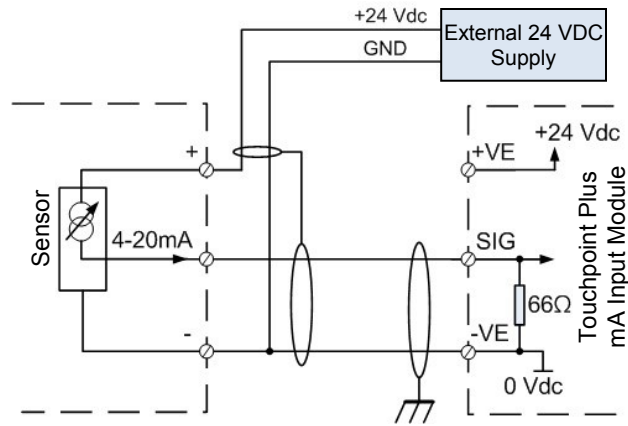

Figure 20. Three Wire Device Powered by an External Source

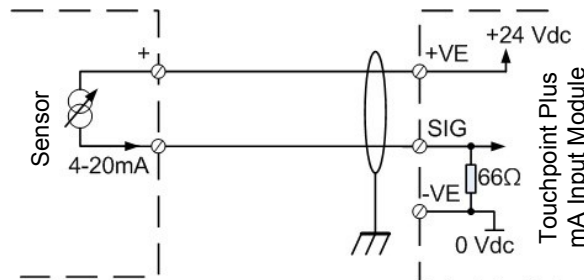

Figure 21. Two Wire Device Powered by a mA Input Module

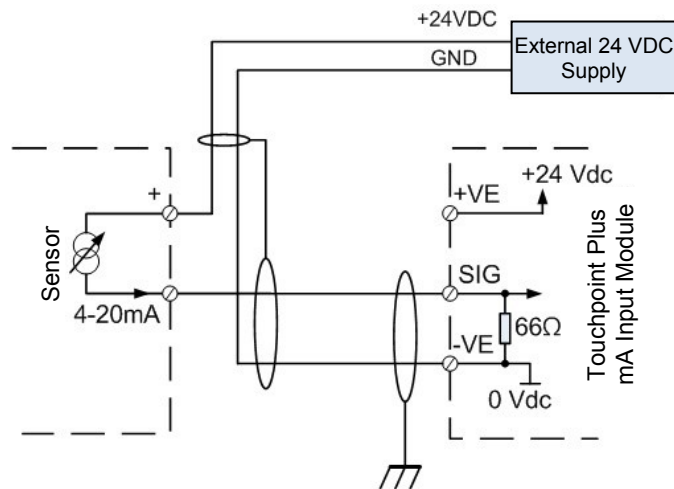

Figure 22. Two Wire Device Powered by an External Source

Electrical Power And Interfacing

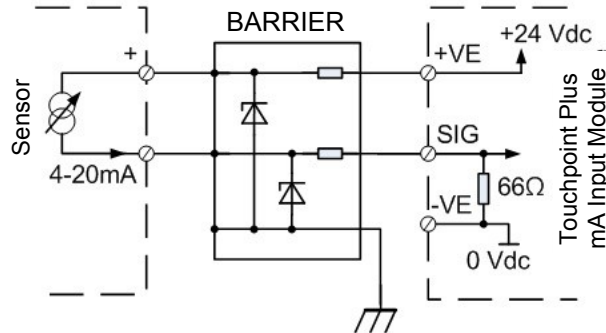

Figure 23. Two Wire Device Barrier Device Powered by a mA Input Module

Note: For intrinsically safe (I.S.) field devices, refer to the device manufacturer’s instructions for details of suitably approved I.S. barriers and interconnections.

5.2.6 Grounding

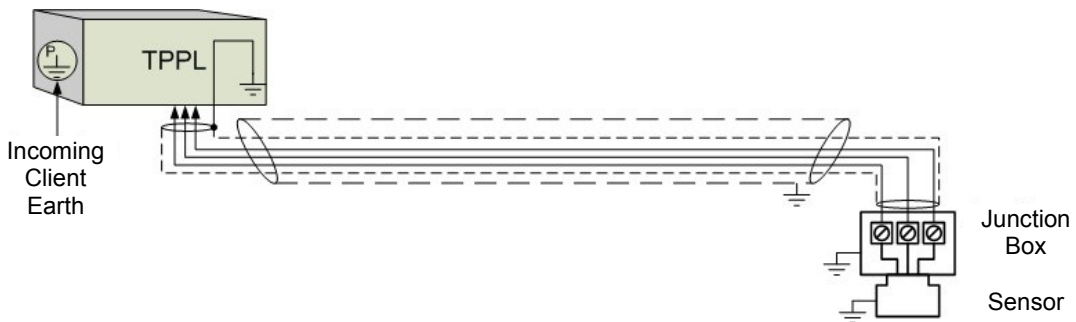

Figure 24. Grounding for Screened Cable with Armour and with Metal Junction Box and Sensor

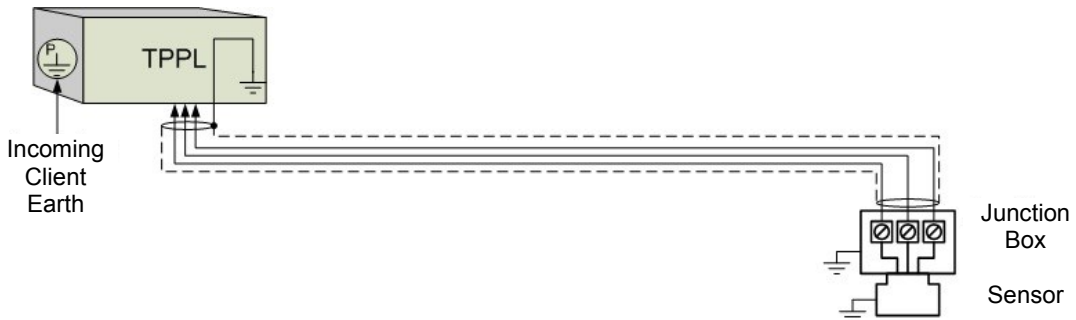

Figure 25. Grounding for Screened Cable, No Armour, with Metal Junction Box and Sensor

Electrical Power And Interfacing

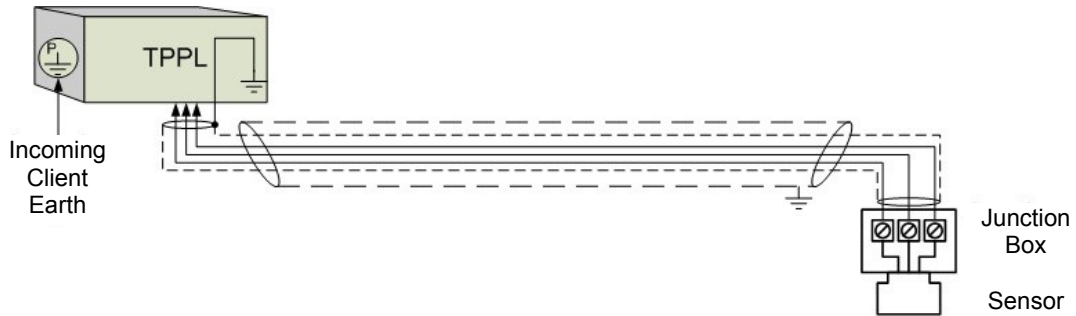

Figure 26. Grounding for Screened and Armoured Cable with Plastic Junction Box and Sensor



Figure 27. Grounding for Screened Cable with Plastic Junction Box and Sensor

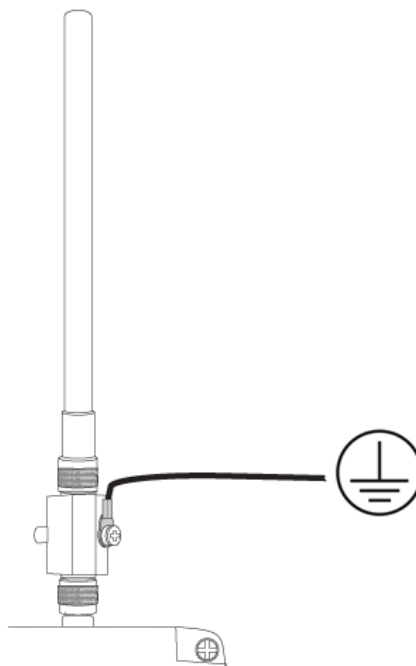

Figure 28. Grounding for Antenna

Electrical Power And Interfacing

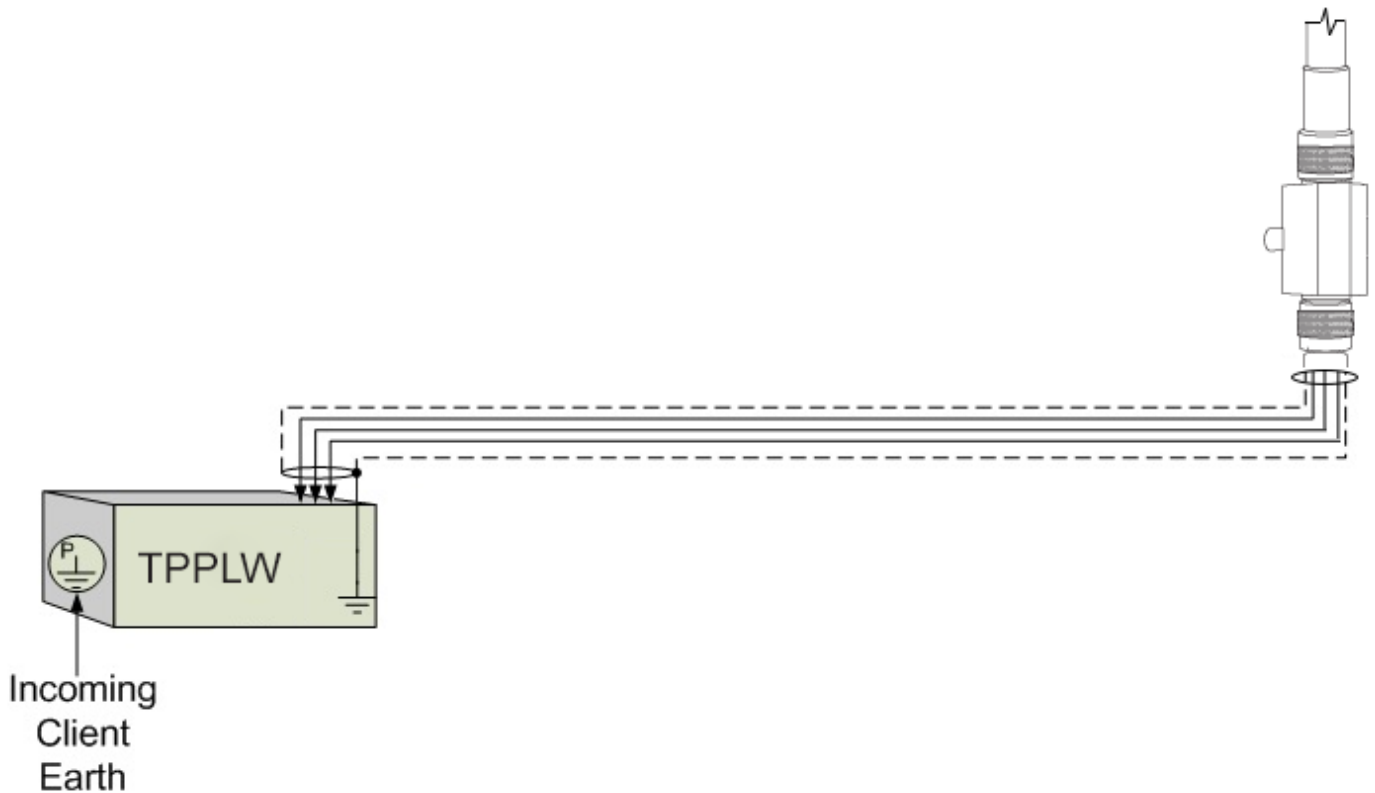

Figure 29. Grounding for Antenna Extension

For lightning surge protection, install a coaxial lightning surge protector inline between the antenna and TPPLW. The lightning surge protector must be earth-grounded: A wire must run directly from the lightning surge protector to a verified ground source such as a copper or copper-clad rod that is set into the ground. A minimum wire gauge of 10AWG or heavier (depending on local electrical ordinance) must be used.

5.2.7 Wireless Module Connections

Input/Outputs	Label	Terminal Identification
Antenna	ANT	1
RAEMet	WIND	2

Electrical Power And Interfacing

5.2.8 Antenna Installation

Install the antenna by screwing it onto TPPLW towards the right.

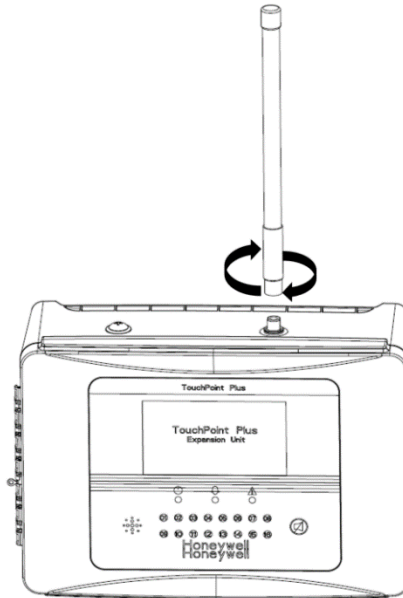

5.2.9 Antenna Extension Connection

WARNING – EXPLOSION HAZARD

Do not disconnect equipment unless power has been removed or the area is known to be non-hazardous.

For antenna extension, use 10 m antenna extension cable (PN: TPPLWOCBL). If an extension antenna is to be used outdoors, especially if it is to be located in an area prone to lightning, a coaxial lightning surge protector must be installed inline between the antenna and TPPLW.

Refer to the end of Ch.5.2.6 Grounding for instructions on installation of lightning surge protection.

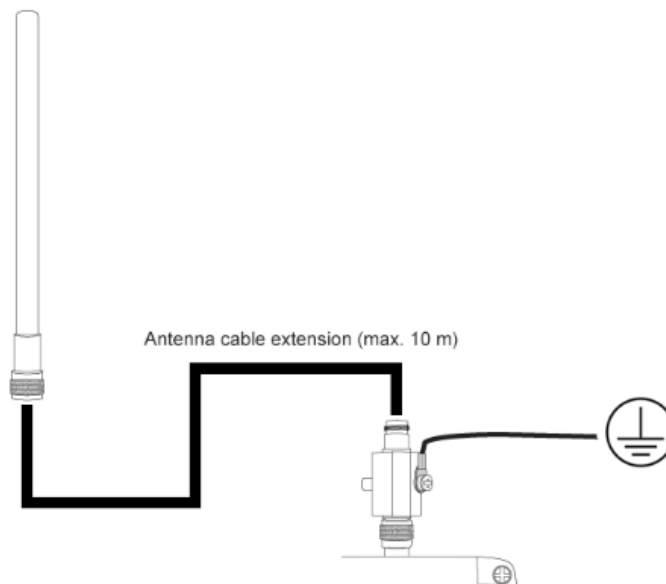

Electrical Power And Interfacing

5.2.10 FA324 Connection

WARNING

Connecting FA324 to TPPLW invalidates certification of TPPLW.

WARNING – EXPLOSION HAZARD

FA324 is not available in Class 1 Division 2. Do not use FA324 in hazardous area.



Figure 30. FA324 Connection

1. Make sure that TPPLW is powered off.
2. Connect FA324 Connector Cable 1 referring to Figure 1.
3. Connect FA324 Connector Cable 2 referring to Figure 2.
4. To anchor the FA324 Connector Cable 2's end(female type) to the TPPLW bottom enclosure, remove a plug from one of cable entry gland of the enclosure first. Fix the FA324 Connector Cable 2 to the enclosure (refer to DETAIL A).
5. Connect FA324 Cable's end(male type) to the enclosure and fasten its nut (refer to DETAIL A).

Electrical Power And Interfacing

Figure 31. FA324 Connector Cable 1 Wiring

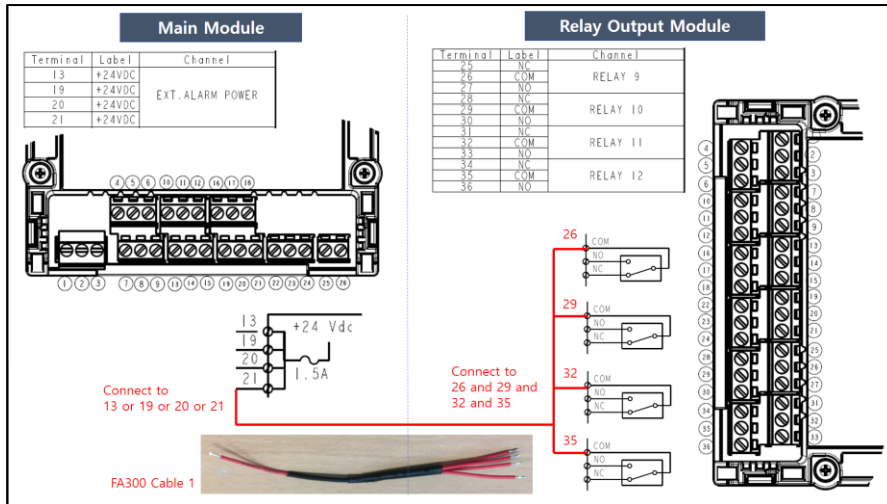
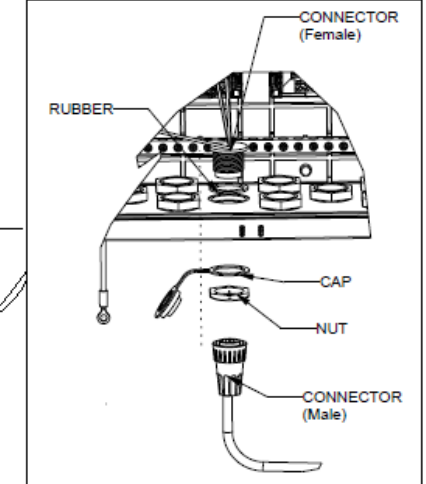
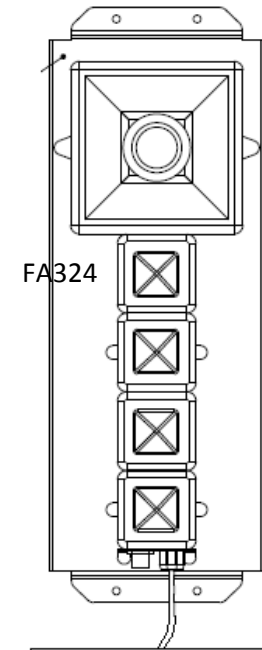
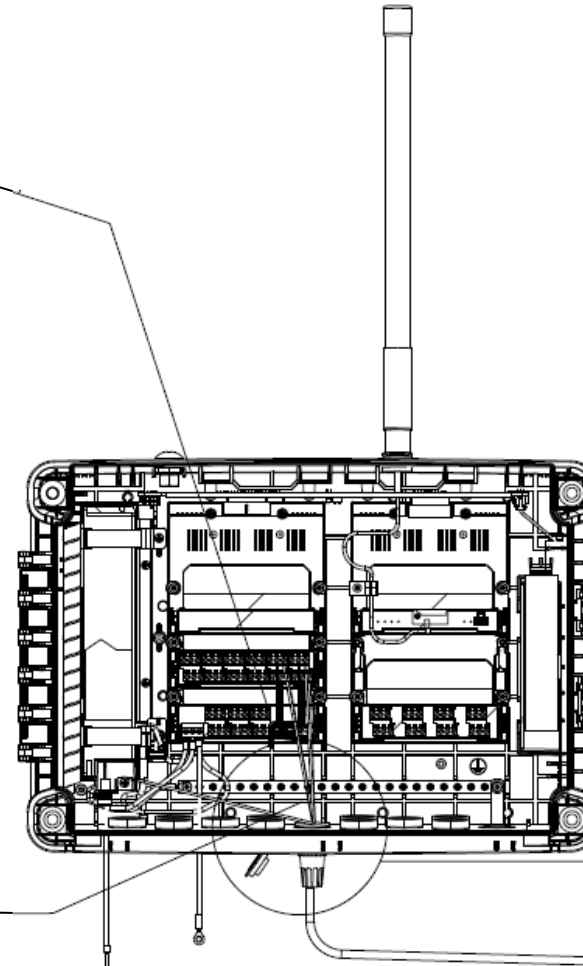
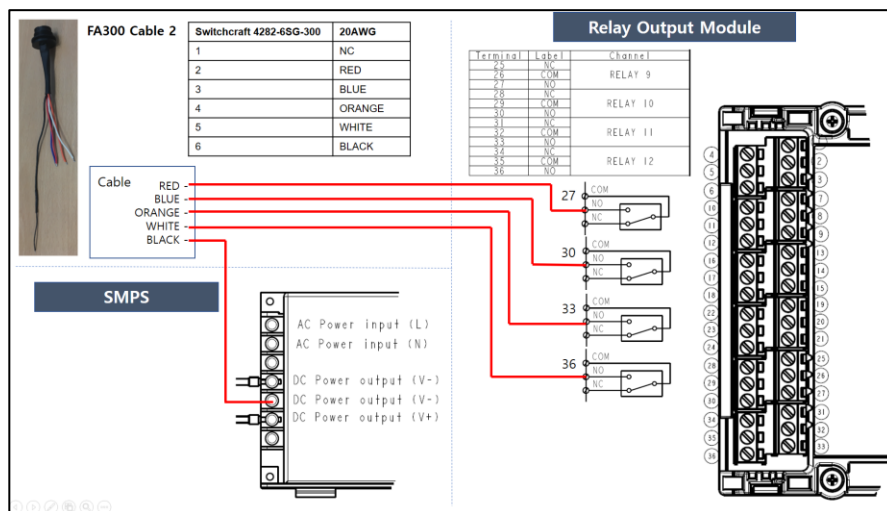

Figure 32. FA324 Connector Cable 2 Wiring



- Contents**
- ❶ FA324 Connector Cable 1
 - ❷ FA324 Connector Cable 2

Electrical Power And Interfacing

5.2.11 RAEMet Wind Sensor Connection

WARNING – EXPLOSION HAZARD

Do not disconnect equipment unless power has been removed or the area is known to be non-hazardous.

WARNING

For Touchpoint Plus Wireless I/O Module, the Wind Sensor must be connected through Sensor Connector (J5) only with maximum wire length of 10 m (32.8ft).

1. Make sure that TPPLW is powered off.
2. Plug the Connector Cable to Wireless Module (refer to DETAIL A).
3. Connect the Connector Cable's ground cable to the earth rail (refer to DETAIL B).
4. To anchor the Connector Cable's end(female type) to the TPPLW bottom enclosure, remove a plug from the most right cable entry gland of the enclosure first. Fix the Connector Cable to the enclosure (refer to DETAIL C).
5. Connect Wind Sensor Cable's end(male type) to the enclosure (refer to DETAIL C).
6. Fasten the Mounting bracket to the pole using U-clamps (Pole Mounting Case).
7. Put the Wind Sensor Cable through the Wind Sensor Cone.
8. Place the Wind Sensor(RAEMet) on the Mounting Bracket plate and fix it tight screwing into the Wind Sensor Cone. Make sure the Wind Sensor is placed in a horizontal position.

Electrical Power And Interfacing

Figure 33. RAEMet Wind Sensor Connection

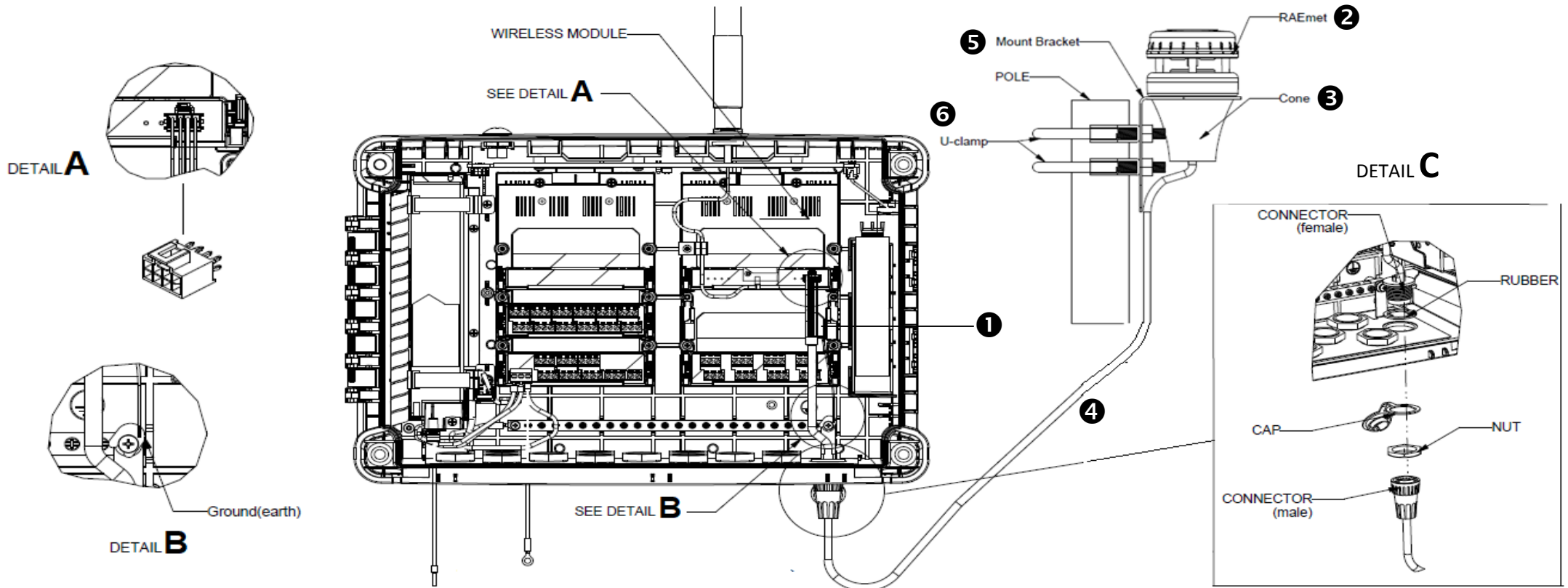

- Contents**
- ① Connector Cable
 - ② Wind Sensor (RAEMet)
 - ③ Wind Sensor Cone
 - ④ Wind Sensor Cable
 - ⑤ Mounting Bracket
 - ⑥ U-clamp (2EA)

Electrical Power And Interfacing

5.2.12 Relay Output Module Connections

Relay Outputs	Label	Terminal Identification
RLY 1	NC	1
	COM	2
	NO	3
RLY 2	NC	4
	COM	5
	NO	6
RLY 3	NC	7
	COM	8
	NO	9
RLY 4	NC	10
	COM	11
	NO	12
RLY 5	NC	13
	COM	14
	NO	15
RLY 6	NC	16
	COM	17
	NO	18
RLY 7	NC	19
	COM	20
	NO	21
RLY 8	NC	22
	COM	23
	NO	24
RLY 9	NC	25
	COM	26
	NO	27
RLY 10	NC	28
	COM	29
	NO	30
RLY 11	NC	31
	COM	32
	NO	33
RLY 12	NC	34
	COM	35
	NO	36

Table 8. Relay Output Module Connections

Electrical Power And Interfacing

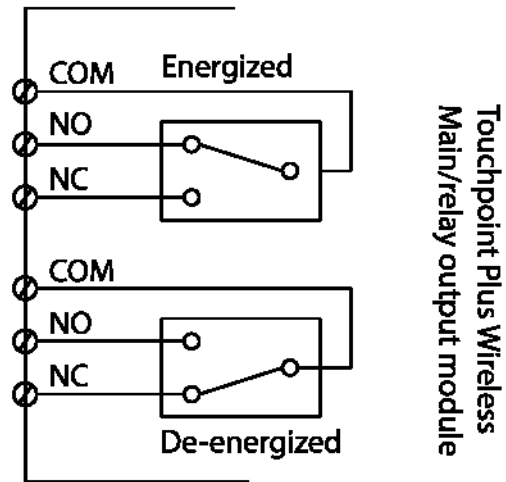

Figure 34. Relay States

Operating Instructions

Chapter 6 – Touchpoint Plus Wireless Operating Instructions

6.1 User Interface General



Figure 35. Touchpoint Plus Wireless Controller User Interface

The User Interface panel (shown above) has:

- A colour touchscreen for normal system operation, maintenance and configuration
- Power, Alarm / Fault and Inhibit state LEDs
- Active Channel (01 to 08) status indicators (Ch. 07 is NOT commissioned in this example)
- R1 to R8 indicate active RAEPint in the system
- Accept (Silence) and Reset membrane button (Right side)
- Integral Alarm Buzzer (Left side)

Further System Interfaces consist of:

- Remote inhibit and remote reset terminals on the Main module
- One fixed relay and two configurable relays on Main Module for system Failure, Alarm and inhibit
- Three dedicated alarm outputs for visual and audio alarms on Main module
- An optional SD card

The interface firmware has two distinct modes of operation – Configuration Mode and Visualisation Mode, and access to certain functions is restricted by the use of password protected access levels. There are four hierarchical access levels: View mode is available to all users while Operator, Service and Administrator modes are password protected. Password holders can be assigned one access level only.

CAUTION

Direct sunlight, solvents, abrasives and sharp edged or metal tools may cause irreparable damage to the LCD panel and membrane.

Use only damp cloths or computer screen wipes to clean it.

Operating Instructions

6.2 Menu Items and Access Levels

The table below details the menu items and access levels for the User Interface. The password hierarchy is Administrator, then Service, then Operator. Broadly speaking, the Administrator can commission modules and configure channels, the Service can edit channel configuration and do calibration, and the Operator can interact with the system during normal day-to-day operation such as acknowledging and resetting events.

A user can log in by selecting an access level and then inputting a password that is valid for that access level.

Note: The default password is 'TPPL' for all access levels. Refer to Ch.7.4 Program Password for more information.

Note: LCD backlight timeout : 30 seconds, Menu timeout: 90 seconds, Authentication timeout:15 minutes. Items shown with a clock symbol timeout after 15 minutes of inactivity.

Key: ● = Allowed, ○ = Denied, ⌚ = Fixed timeout.

↪ = sub-menu, ↪↪ = sub-sub-menu

Menu Item	Admin.	Service	Operator	Others
Login ⌚	●	●	●	○
Menu Home	●	●	●	●
Information	●	●	●	●
↪ System Info	●	●	●	●
↪↪ Summary Info	●	●	●	●
↪↪ Software Info	●	●	●	●
↪↪ Parameter Info	●	●	●	●
↪ Event History	●	●	●	●
↪↪ Filter View	●	●	●	●
↪↪ Export History	●	●	●	●
↪ Trend/Plot	●	●	●	●
↪ Channel Info	●	●	●	●
↪ Module Info	●	●	●	●
↪ Relay Status	●	●	●	●
↪ Additional Status	●	●	●	●
↪ Network	●	●	●	●
↪ Service Contract	●	●	●	●
Event History	●	●	●	●
Channel View Home	●	●	●	●
↪ List View	●	●	●	●
↪ Tile View	●	●	●	●
↪ Summary View	●	●	●	●
Configuration	●	●	○	○
↪ Channel Settings	●	●	○	○
↪↪ mA Input Channel	●	●	○	○
↪↪ mV Input Channel	●	●	○	○

Operating Instructions

Menu Item	Admin.	Service	Operator	Others
↔↔ Relay Output	●	●	○	○
↔↔ Wireless Module	●	●	○	○
↔ HW Module Control Panel	●	●	○	○
↔ General	●	●	○	○
↔↔ Date / Time	●	●	○	○
↔↔ Language	●	●	○	○
↔↔ Service Contract	●	●	○	○
↔↔ Home Settings	●	●	○	○
↔↔ Timeout	●	●	○	○
↔↔ Display	●	●	○	○
↔↔ Outputs	●	●	○	○
↔ Log Interval and Threshold	●	●	○	○
↔↔ mA Input	●	●	○	○
↔↔ Wireless Input	●	●	○	○
↔ Security	●	●	○	○
↔↔ Password	●	●	○	○
↔↔ Remote Access (Buttons)	●	●	○	○
↔↔ Pre-shared Key	●	●	○	○
↔ Config Manager	●	●	○	○
↔↔ Import	●	●	○	○
↔↔ Export	●	●	○	○
↔ Network	●	●	○	○
↔↔ Ethernet	●	●	○	○
↔↔ Modbus RTU	●	●	○	○
↔↔ Modbus TCP/IP	●	●	○	○
↔↔ Mesh network	●	●	○	○
↔↔ Refresh network	●	●	○	○
Maintenance	●	●	●	○
↔ Reset Alarms / Faults	●	●	●	○
↔ Reset All Peaks	●	●	●	○
↔ Gas Calibration ⚠	●	●	○	○
↔ Service Mode ⚠	●	○	○	○
↔↔ Electronic Adjustment ⚠	●	○	○	○
↔↔ Reset to Defaults ⚠	●	○	○	○
↔ Update System ⚠	●	○	○	○
↔↔ Software ⚠	●	○	○	○
↔↔ Language ⚠	●	○	○	○
↔↔ Sensor Catalogue ⚠	●	○	○	○
↔↔ Module Data ⚠	●	○	○	○

Operating Instructions

Menu Item	Admin.	Service	Operator	Others
↵ SD Card	●	●	○	○
↵↵ Eject	●	●	○	○
↵↵ Format	●	●	○	○
↵ Power Off ☹	●	●	○	○
System Test	●	●	○	○
↵ Force Relay ☹	●	●	○	○
↵ Dedicated Alarm contact ☹	●	●	○	○
↵ LCD Test ☹	●	●	○	○
↵ LED and Buzzer test ☹	●	●	○	○
↵ Mesh network test ☹	●	●	○	○

Table 9. User / Component Matrix

Operating Instructions

6.2.1 Touchscreen (Colour Resistive)

The touchscreen is activated using a finger or a stylus (only). Do not use sharp or abrasive objects as they may cause irreparable damage.

All interactions are single tap.

6.3 SD Card

The Touchpoint Plus Wireless accepts standard SD cards of 2 to 32 GB (FAT32).

The SD card is used to store the system event history. Touchpoint Plus Wireless logs all events and all changes to input readings. A notification will be given when the SD card is less than 50Mbytes space. If the card is not replaced or not freed up, a further notification will be given when it is full, and when data is being overwritten.

Directory / Filename	Data	Frequency
:\LOG\GASDATA\MMMYYYY\YYMMDD.csv	Gas logging data	Every day
:\LOG\GASDATA\MMMYYYY\YYYYMMDD_ConfigurationExport.TXT	Updated parameters	Power on, User updating
:\LOG\EVENT\EVYYYYMM.csv	Event log	Every month
:\LOG\EXPORT\EVYYYYMMDDHHMMSS.csv	Exported event history	User on demand
:\CFG	Exported configuration	User on demand

Note: “Index” field in Gas logging data, “SD card:\LOG\GASDATA\MMMYYYY\YYMMDD.csv” is for channel numbers (1~8) for analog inputs and sensor count for a wireless node.

Note: The SD Card must remain inserted during normal system operation as the on-board flash memory is limited to a few minutes of events. When the card is full it should be replaced or freed up almost immediately to avoid data loss.

Note: The SD Cards must be empty and setup by TPPLW following first installation, and they should be used for TPPLW data only. Data can be transferred or copied to a PC via a Card Reader and the card reused, but care must be taken not to overwrite previous data files, and a reliable backup system should be used.

Note: The SD card have to set unlocked for data logging

Note: It is recommended to format the SD card before use by selecting TPPLW Menu > Maintenance > SD Card > Format

Operating Instructions

6.4 Normal Operation (Safety Functions)

During normal operation:

- The Touchpoint Plus Wireless system will collect analog input sensor data every 1 second.
- The Touchpoint Plus Wireless system will collect wireless input nodes sensor data every 60 second (depending on node setting: 1 second ~ 600 seconds)
- Input channel gas calculation is compared to alarm setpoints every 500 ms.
- Cycle time of the Main Module is 1 second until data are sent to the output modules (UI, relay, mA)
- Any change in status of an I/O channel will be reported to the User Interface and logged in the event history
- Events (Alarms, Faults, Inhibits, etc.) will be reported to the User Interface and logged in the event history
- Any fault within the system will activate the System Fault relay
- Any failure of the safety function i.e. due to major fault or power loss will activate the System Failure relay

6.5 Overview – Touchscreen Interface

See Ch.12 Glossary of Icons for details about individual icons.

6.5.1 User Interface Screen

The User Interface shows the current status of the Touchpoint Plus Wireless system as follows:

- Channel Summary – Display shows total counts for alarm 1, alarm 2, alarm 3, fault, warning and inhibits
- Channel Tile – Display shows up to eight inputs and events
- Online monitor fault icon(🔌🚨) - Wireless nodes connection counts are less than user setting.

Key to examples below:

- Channel marking in red – one or more input channels are in **Alarm**
- Channel marking in yellow – one or more channels are in **Fault**
- Channel marking in orange – one or more channels are in **Inhibit**
- Channel marking in blue – one or more channels are in **Warning**

Tip: You can use the colour-matched filter icons to list a series of specific event types.

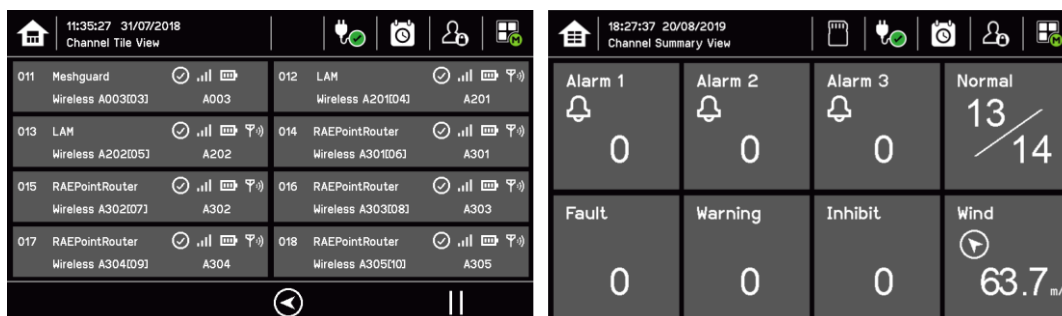

Operating Instructions

The icons in the navigation toolbar are used to navigate through the User Interface options.

Channel Input screen:

	Tile View
	Summary View

Channel detail screen:

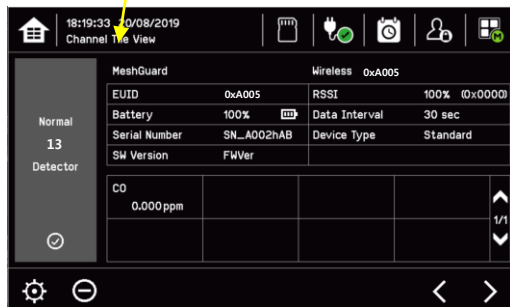
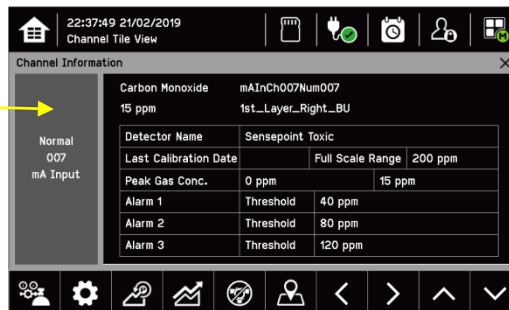
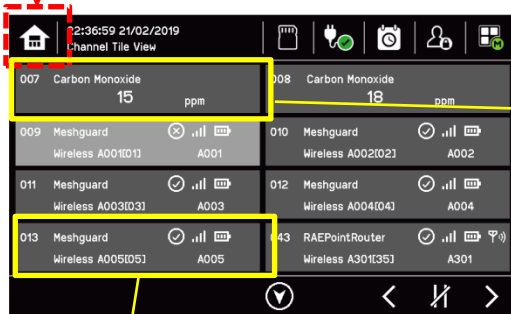
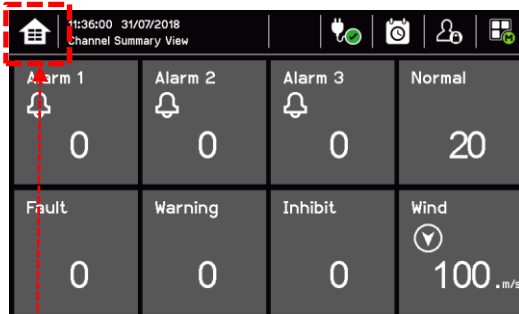

Wireless Node Icons

	Wireless Node Online		Wireless RSSI
	Wireless Node Offline		Wireless Node Battery Level
	Wireless Node Router Mode		Modem ID

Operating Instructions

6.5.2 Navigation – Active Events and Filtering

You can change the list type by using Filters from one of the Tile views:

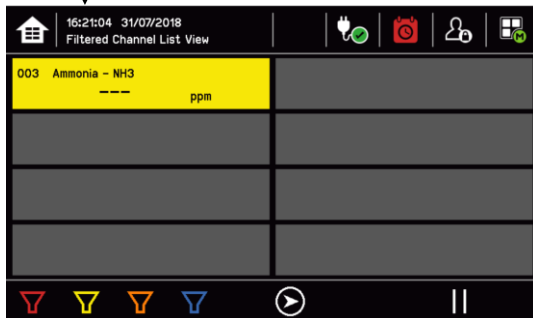
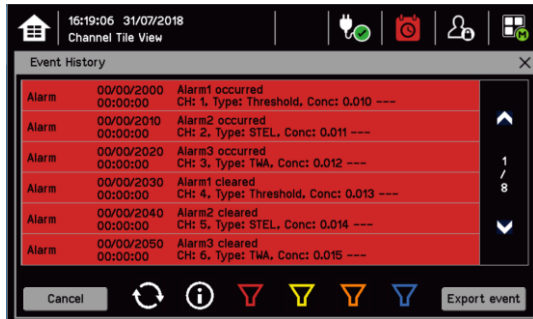

Key to Filters:



- Red: Alarm
- Yellow: Fault
- Orange: Inhibit
- Blue: Warning

Operating Instructions

6.5.3 Navigation – Menu

User must have the appropriate access level password to enter Maintenance, Configuration and System test options.

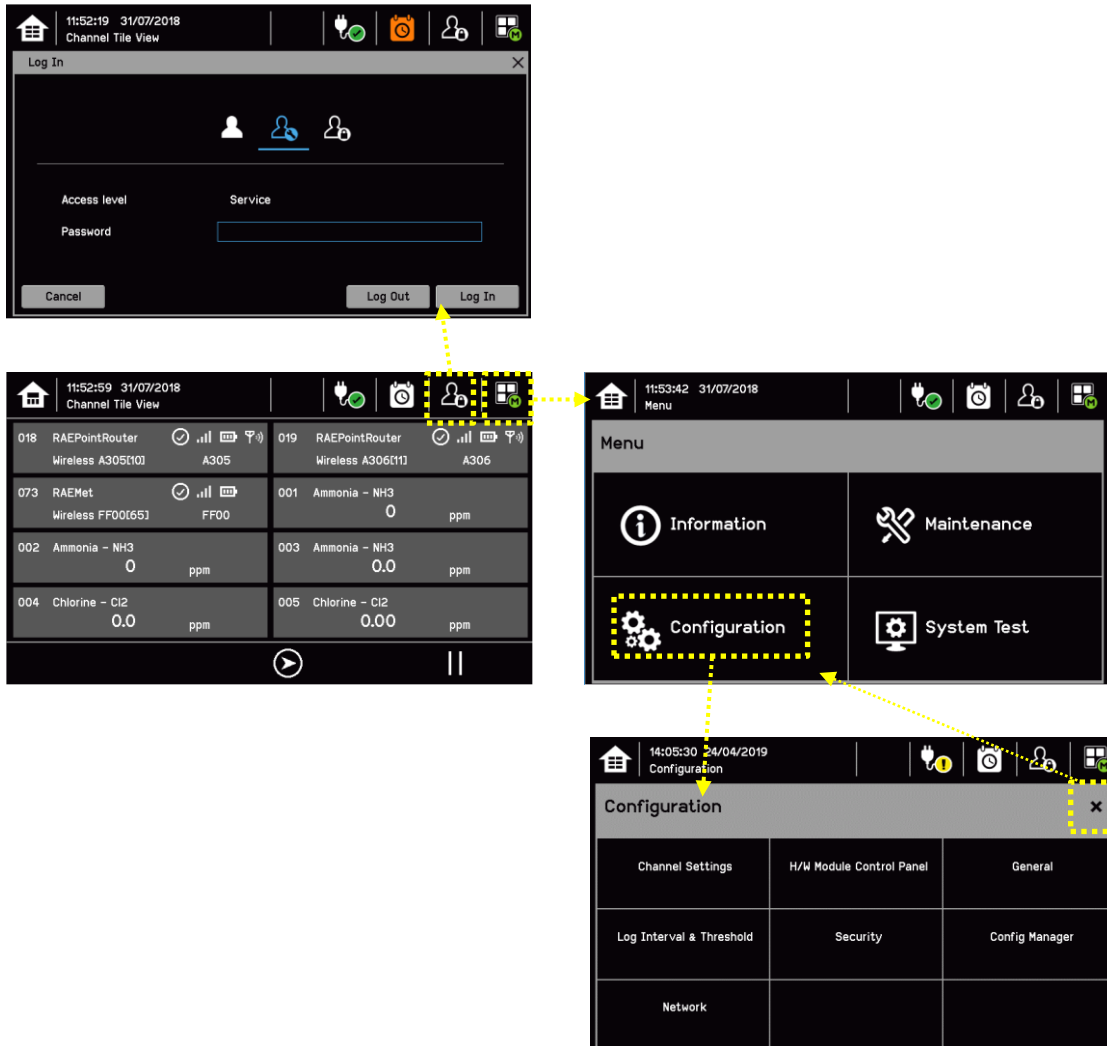





Note: Depending on menu timeout settings, the system will log out and return to Inputs/Outputs screen. The authentication (logout) timeout also depends on user configuration. The default authentication timeout is set to 15 minutes.

Operating Instructions

6.5.4 Navigation – Active Access Level Icons

You must enter a valid password to login.

	No one is logged in
	Operator is logged in
	Service engineer is logged in
	Administrator is logged in

Note: The system will log out after 15 minutes of inactivity. User can adjust the timeout interval

6.6 Alarms

6.6.1 View active alarms

Active alarms can be viewed:

- 1) From the Input screen, select the red filter icon:

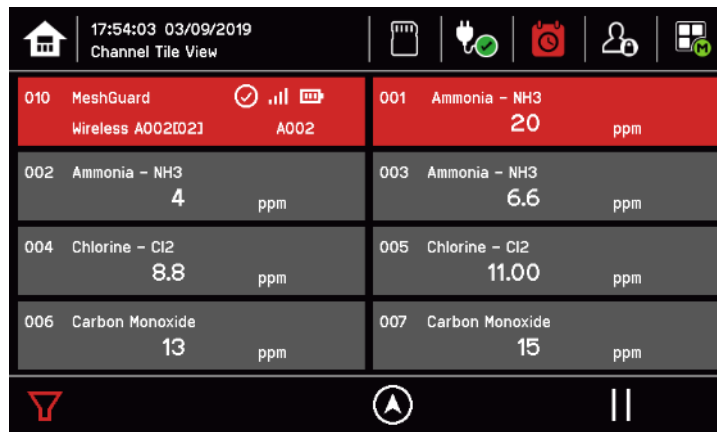

The screen will display a list of the input channels with active Alarms, starting with the most recent event.

Unacknowledged alarms will flash, acknowledged ones will be stay on. Touch the Accept button to acknowledge the alarms.

Note: the display will show the channel ID, location tag. If more than one alarm level has been triggered on the same channel, a high priority alarm levels will be shown.

Operating Instructions

6.6.2 Acknowledge an active alarm

Note: Operator or higher level access is required.

Note: Accept and Acknowledge have the same meaning in this context.

An active Alarm can be acknowledged by touching the **Accept** button for >1 second. This will acknowledge ALL active events and the channel LED and icon will stop flashing.

When an alarm is acknowledged the buzzer will be silenced and the alarm will stop flashing.

Note: If a Relay Output channel has the Alarm Update function enabled, the alarm will be ignored for the Cause and Effect matrix once it is acknowledged.

6.6.3 Reset a latched alarm

A latched alarm is one that cannot automatically reset itself when the triggering event has cleared.

Note: Operator or higher access level is required (optional, see Commissioning, Buzzer Activation and Button Password Protection).

A latched alarm can be reset in three ways by:

- 1) Touching the **Reset** button for >3 seconds. This will reset ALL latched alarms, faults and warnings, provided that the triggering event has cleared. It will also reset any latched relay outputs.
- 2) Selecting Menu > Maintenance > Reset alarms/Faults. This will reset all latched events for the channel, provided that the input signal has returned to Normal status.
- 3) Holding the Remote reset switch for >3 seconds. TPPLW has the option of adding a remote acknowledge / reset switch up to 500 m away from the Controller, but care should be taken to prevent unauthorised people accessing the switch.

Warning

A gas detector may indicate that the gas concentration in its vicinity has dropped to a safe level, but this does not mean that a dangerous atmosphere doesn't persist elsewhere in that area. Do not reset the alarms until the area has been confirmed to be safe or has been adequately ventilated.

Operating Instructions

6.7 Faults and Warnings

6.7.1 View Faults and Warnings

Detailed information about active Faults and Warnings can be viewed:

- 1) From the Input and output screen, select either the Fault (yellow filter) icon, or the Warning (blue filter) icon. The screen will show a filtered list of only the active Faults or Warnings.

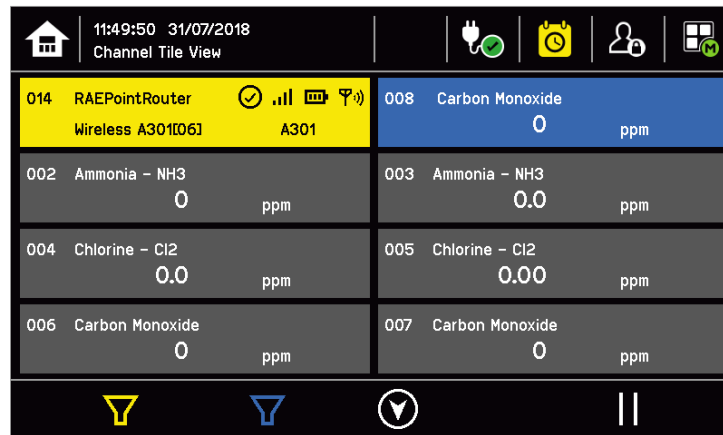

CAUTION

Wireless node disconnections are not fault until online monitor fault  (Disconnected nodes > Online monitor)

6.7.2 Acknowledging an Active Fault or Warning

Note: Operator or higher level access is required

Note: Accept and Acknowledge have the same meaning in this context.

An active fault or warning can be acknowledged by touching the **Accept** button for >1 second. This will acknowledge ALL active events and the channel LED and icon will stop flashing.

6.7.3 Reset a Latched Fault or Warning

Note: Operator or higher access level is required.

A latched fault or warning can be reset in three ways by:

- 1) Touching the Reset button for >3 seconds. This will reset ALL latched alarms, faults and warnings, provided that the event has cleared. It will also reset any latched relay outputs.
- 2) Selecting Menu > Maintenance > Reset alarms/faults. This will reset all latched events for the channel, provided that the input signal has returned to Normal / within tolerance.
- 3) Remote reset input.

Operating Instructions

6.8 Inhibit

Note: Service or higher access level is required. (Analog input only)

Input channels can be inhibited by:

- 1) Selecting a channel and then touching the inhibit icon: 
- 2) Remote inhibit input (locking switch)

To clear inhibits, select the required channel and then select **Clear Inhibit**.

Note: An auto-inhibit cannot be cleared manually. Auto-inhibits may occur during calibration or warm-up, when a transmitter is signalling Inhibit, or when an Inhibit delay time is running.

Note: Inhibit timeouts can be set by configuring the channel, as shown below:

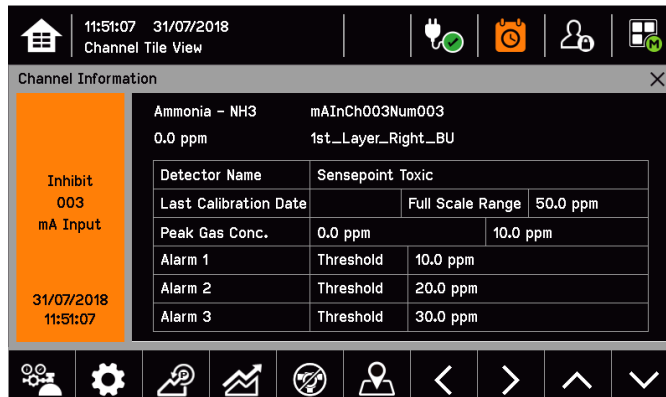

Channel Information			
Inhibit 003 mA Input 31/07/2018 11:51:07	Ammonia - NH3		mAInCh003Num003
	0.0 ppm		1st_Layer_Right_BU
	Detector Name		Sensepoint Toxic
	Last Calibration Date		Full Scale Range 50.0 ppm
	Peak Gas Conc.		0.0 ppm 10.0 ppm
	Alarm 1		Threshold 10.0 ppm
	Alarm 2		Threshold 20.0 ppm
	Alarm 3		Threshold 30.0 ppm

6.9 Viewing Input Channels and Input Details

From the Input screen, toggle the Home icon  between Channel Tile > Channel Summary > Channel Output.

- 1) From the Input screen, select Channel List or Channel Tile.
- 2) A list of all input channels is shown in order of channel ID. The channel ID, gas name, status minimum/maximum peak concentration and current reading will be shown.
- 3) The list can be filtered by status – Alarm, Fault, Inhibit, Warning or All.
- 4) Select a channel and Channel detail screen will show up as shown below. Depending on access level, a number of options will be shown.

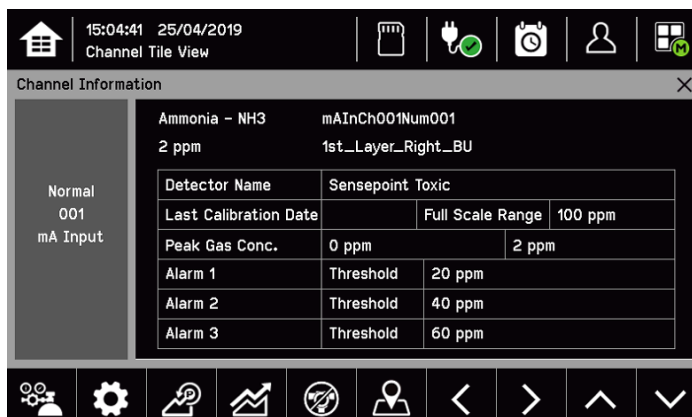

Channel Information			
Normal 001 mA Input	Ammonia - NH3		mAInCh001Num001
	2 ppm		1st_Layer_Right_BU
	Detector Name		Sensepoint Toxic
	Last Calibration Date		Full Scale Range 100 ppm
	Peak Gas Conc.		0 ppm 2 ppm
	Alarm 1		Threshold 20 ppm
	Alarm 2		Threshold 40 ppm
	Alarm 3		Threshold 60 ppm

Operating Instructions

Function	Access Level	Comment
Calibration	Service	Option to calibrate the channel
Channel configuration	Service	Change the input channel configurations
Peak reset	Service	Reset peak reading of the channel
Inhibit	Service	Inhibits the channel. On an inhibited channel, this option is Clear Inhibit. See Normal Operation, Inhibit for more information.
Trend Graph	Viewer	Shows the trend graph for the channel. See Normal Operation, View Trend Graph for more information
Channel location	Viewer	Show physical position of IO Module and channel.
Input Details	Viewer	Shows detailed information about the channel including Custom ID, sensor and gas name, gas reading, configured alarms and alarm levels

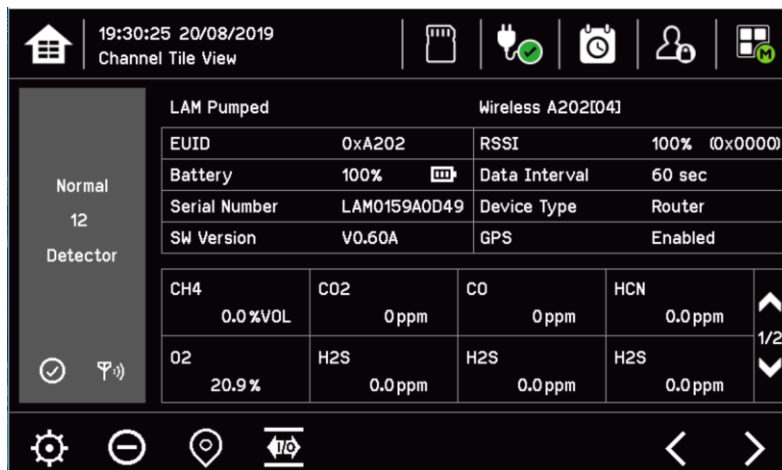

Function	Access Level	Comment
Channel configuration	Service	Change the input channel configurations
GPS location	Service	Show GPS data for an input (GPS enabled products only)
Node detail	Service	Detector type, PAN ID, SN, Battery level, SW version, RSSI, data interval, GPS state and gas readings

Operating Instructions

6.10 Viewing the Trend Graph

Trend graph is drawn using one minute average reading so it is not suitable to view the short-term signal fluctuations.

To view the graph:

- 1) Select the Menu > Information > Trend/Plot.
- 2) Select the required channel, and then select Data range.
- 3) The trend graph will be displayed.

Note: Touchpoint Plus Wireless does not adjust automatically for daylight savings time so Touchpoint Plus Wireless will retain a backup of the earlier data if the clock is backdated (i.e. when ending daylight savings time).

Note: Touchpoint Plus Wireless will retain latest 8 hr data and will be cleared after power reset for trend graph

6.11 Viewing Event History and Export

The event history for the complete system can be viewed in date order (latest first). The history can be filtered by Alarm, Fault, Inhibit, Warning.

To view the event history: select Menu > Information > Event History. Or touch Event icon.

Note: Touchpoint Plus Wireless does not adjust automatically for daylight savings time so Touchpoint Plus Wireless will retain a backup of the earlier data if the clock is backdated (i.e. when ending daylight savings time).

Active event data is saved to the SD card automatically if one is installed. The event history data can also be exported to the SD card on demand.

To export the event history: select Menu > Information > Event History > Export Event.

Note: Make sure a SD card with sufficient empty space is installed before Exporting. See Checking the Capacity of the SD Card below for more information.

Note: Microsoft Excel 2003 is limited to a maximum of 65,526 entries. If the report is larger than this a message 'file not loaded completely' may be generated by Microsoft Excel 2003. Microsoft Excel 2010 has a much larger capacity which should be sufficient for all Touchpoint Plus Wireless generated reports.

Note: Touchpoint Plus Wireless does not adjust automatically for daylight savings time so Touchpoint Plus Wireless will retain a backup of the earlier data if the clock is backdated (i.e. when ending daylight savings time).

6.12 Checking the Capacity of the SD Card

Select Menu > Information > Additional Status. This will show the size and remaining space on the inserted SD Card. Refer to the Maintenance chapter for details of how to replace the card.

The Touchpoint Plus Wireless accepts standard SD cards of 2 to 32 GB (FAT32).

Operating Instructions

6.13 Accessing the System Information and Service Contact Details

Select **Menu > Information > System information > About** to view details about the Firmware, Software and serial numbers.

Select **Menu > Information > Service Contact** for details of how to access technical support.

6.14 System State Relays

The Main Module has three System State relays, rated at 30 VDC, 3 A or 250 VAC, 3 A, that activate under the following conditions:

- One or both System-State relays can activate if there is any active alarm, fault, warning or inhibit in the system (if configured)
- The System-Failure relay can activate if the safety function of the system is not operating, for example due to a major fault or power loss

Commissioning

Chapter 7 – Commissioning

7.1 Introduction

This chapter explains several tasks that may be required during commissioning.

First time switch-on and Commissioning should only be carried out by a Honeywell engineer or someone with System Administrator privileges who has been trained in accordance with this manual.

During First Time Switch On, it will be necessary to confirm or set the Date, Time and Language, to set new passwords and delete the default password.

If the system was ordered from Honeywell Analytics, complete Ch.7.5 Commission Input / Output Modules and Ch.7.6.3 Configuring a Channel before proceeding with Ch.7.6.6 Configuring Relay Output Channels.

7.2 First Time Switch On

Before switching power on, ensure that a qualified person has checked that the wiring is safe and conforms to local regulations, and that all electrical connections are in accordance with Ch.5 Electrical Power Connection and Interfacing. Also check that the battery switches are 'On'. (If a backup battery is fitted)

Switch on the battery switch (if fitted) and apply power. You can use a multi-meter to check that the DC supply to the DC Connector block is between 18 and 32 VDC. (≥24 VDC when a battery is installed.)

The system start up sequence may last for up to 5 minutes depending on the number of channels in use.

When start up is completed, Touchpoint Plus Wireless will display the Input screen, indicating the current status of the system. The Channel tile view is shown below:

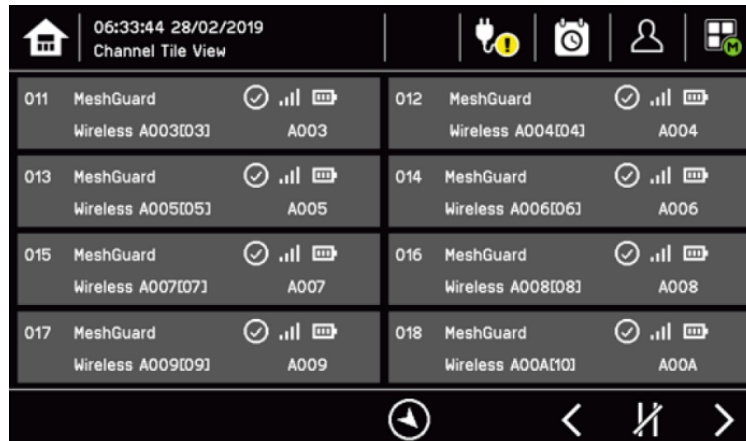

Key to Icons:

	Toggle to select screen layout		Login Status(Admin)
	External main power is provided. Touch for status		Login Status(Service)
	External power is not connected. Touch for status		Login Status(Operator)
	Event History (Inhibit shown)		SD card is detected
	Login Status (Viewer)		Menu
	Toggle auto-scroll on and off		Filter Display (Inhibits shown)
	Online monitoring		Wind direction

Commissioning

7.3 Date, Time and Language Settings

Note: You should replace the coin battery if date and time are not retained after power-cycle

Note: Check regularly that the date and time set for TPPLW are correct, adjust the date and time if needed.

7.3.1 How to Set or Change Date, Time and Language Settings:

- 1) Login with the Service engineer level and default password is 'TPPL' for all access levels.
- 2) Touch the Login icon in the navigation bar and a login will appear for the access level and Password.
- 3) From the navigation bar select Menu > Configuration > General > Date/Time.
- 4) Set the date, time and display format as required.
- 5) Touch Finish.

Note: Touchpoint Plus Wireless does not adjust automatically for daylight savings time so Touchpoint Plus Wireless will retain a backup of the earlier data if the clock is backdated (i.e. when ending daylight savings time).

7.4 Program Passwords

Note: Administrator level access is required to create an Administrator level password. Service level access can create or amend lower levels of password.

Note: Passwords are case sensitive

The following rules apply to user passwords:

- Three password protected levels and one non-password level are available.
- The password must be minimum 8 characters long
- The password must contain a mix of letters, numbers and symbols.
- The password must contain a lower and an upper characters

- 1) Login with a valid Service or Administrator level.
- 2) Select Menu icon > Configuration > Security > Password.
- 3) Select an access level icon and input currently logged user's password, new password and confirm password.
- 4) Touch Change.

Note: Require help from your service contact if you forget a password. The details should have been entered in the Touchpoint Plus Wireless software during commissioning.

CAUTION

Please change the password once you receive TPPLW.
Careless password management can cause unauthorized access to the system which can cause security problem and this is user's responsibility.
If you forget your password please contact Honeywell Analytics service.

CAUTION

To recover your password please contact Honeywell Analytics service.

Commissioning

7.5 Commission Input / Output Modules

Note: Service or higher level access is required

- 1) Login as an Service or higher
- 2) Select Menu > Configuration > H/W Module Control panel
- 3) Select an IO module (a blue block) and touch 'Add'. Select one of the listed I/O Module types.
- 4) Repeat for other installed IO Module.

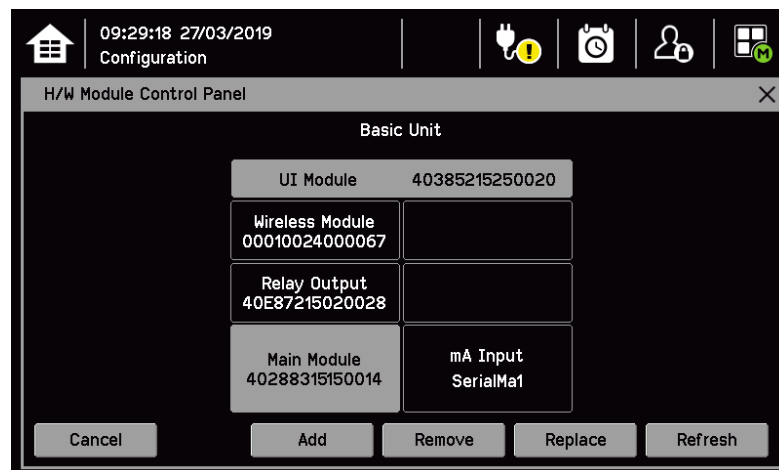

Note: Sky blue blocks show newly installed (i.e. uncommissioned) or decommissioned modules.

Note: To remove a module, Select the Module on the screen and then touch 'Remove'. To replace it with new same type of IO Module, touch 'Replace'.

Commissioning

7.6 Channel Configuration

Note: Service or higher level access is required

Note: There is no calibration reminder in TPPLW. A user can disable the calibration relevant warning by setting the calibration interval to zero.

7.6.1 Introduction

Individual analogue input channel can be configured in two ways – either from the built in sensor catalogue (for Analogue Input modules only), or by completing a full custom configuration.

Individual Wireless input channels can be configured automatically after complete Network setting.

When using the sensor catalogue, channel number and tag must be manually entered and then the rest of the configuration is populated automatically when detector name and sensor type are selected from the pre-defined list.

Note: You can always use the sensor catalogue as a starting point and then amend it afterwards (refer to Ch.7.6.3 Configuring a Channel and Ch.14 Configurable Parameter Reference Guide).

To change any parameter, enter the new value and touch Apply to send it to the system. The system will then return the value, which will be displayed on the screen, and the user must touch Update for the settings to take effect. This requires the user to verify that the correct value has reached the system.

New values can be entered in various ways:

- Free text (i.e. channel tag)
- Numeric keypad
- Check / uncheck a box (i.e. to toggle an alarm between latching and non-latching)
- Select an option by checking a radio button
- Select from a list of available options (i.e. channel number)

The configuration is designed to be simple to follow on the screen. However you can refer to Ch.14 Configurable Parameter Reference Guide to find detailed definitions of all the parameters, default settings and available ranges.

Commissioning

7.6.2 Wireless Network Setting (Mesh Network)

1. Log in as Service or higher level
2. Select menu Configuration > Network > Mesh Network
3. Set PAN ID (0–999)
4. Set wireless Channel (0–26)

Note: Frequency channels 0–11 are assigned for sub 1 GHz depending on region. Frequency channels 12–26 are assigned for 2.4 GHz.

5. Set Radio Power (Max / Middle / Min)
6. Set Online Monitors (0–64). Portable products can be excluded from Online Monitors.

Note: this setting indicates how many monitors the network includes. When the number of online monitors in the network drops below the minimum set here, a Fault is raised.

7. Set Echo View as enabled to initiate Echo View operation
8. Tap on Finish

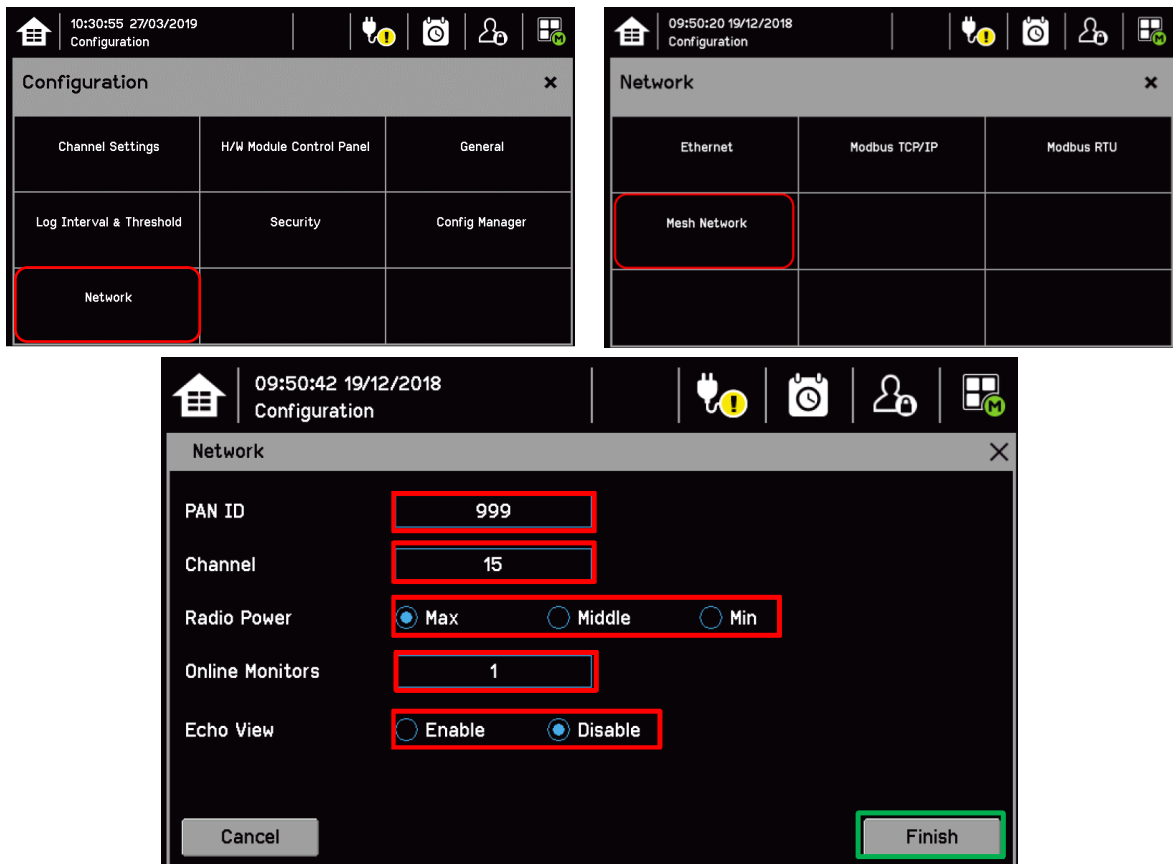

1. User can change key that is used on an encrypted connection. Select menu Configuration > Security > Pre Shared Key
2. Enter the Pre Shared Key and tap on Finish.

Note: Encrypted connection requires accurate date and time settings between controller and nodes. It is only available for products that feature encrypted connection.

Note: Reset all wireless networks when PAN ID has changed.

Commissioning

7.6.3 Configuring a Channel

CAUTION – ALARM INHIBIT

An I/O Module will be set into Configuration State if configuration update is attempted for any of its channels (i.e. Commission Channel or Edit Configuration).

Configuration State means that all commissioned channels on the I/O Module are set into Inhibit state – i.e. the input channels **will not trigger any alarms** and output channels **will not execute any actions**.

You should consider alternative safety measures when performing these procedures.

- 1) Login as an Service or higher access level
- 2) Select Menu > Configuration > Channel settings.
- 3) Select the required Module type.
- 4) Select a required channel and touch 'Select'.
- 5) Select Enable for a required channel
- 6) Select Channel Number and Enter Channel Tag
- 7) Select a detector name and a sensor type to import all relevant configuration parameters from the Sensor Catalog.
- 8) Edit the channel parameters
- 9) Touch Finish if modification of channel settings is complete
- 10) Check whether the channel settings are valid before making it take effect
- 11) Touch Apply

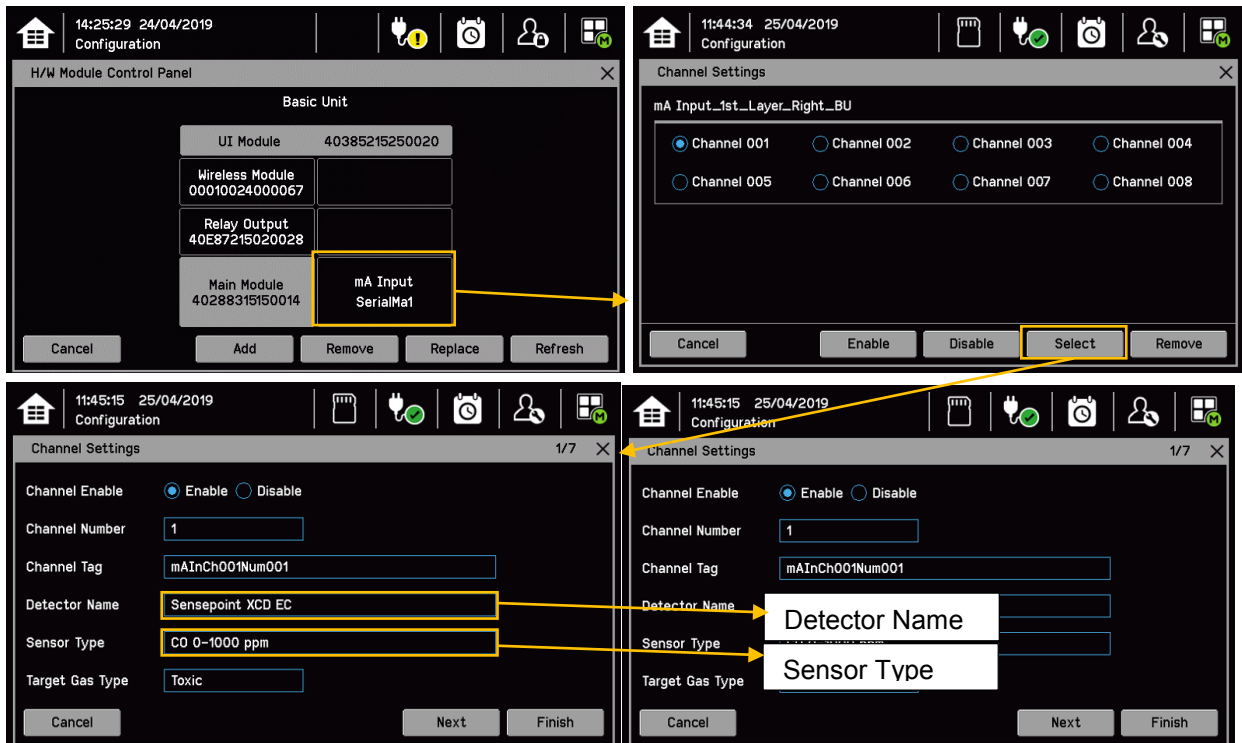

Commissioning

7.6.4 Editing a Configured Channel

WARNING
When selecting a new target gas for units the sensor must be recalibrated.

Note: There was two kinds of timeout in menu mode. One is menu timeout and the other is authentication time out. If there is no touch input, then it will move to upper menu and then finally back to Channel Status screen. The menu timeout can be configured in Configuration > General > Timeout. The default menu timeout is 90 seconds. The authentication timeout is to force the user to log out automatically when there is no activity for the configured duration. If the user logged out automatically due to authentication timeout, a user will be asked to log in again.

To edit an already configured channel:

- 1) Login as an Service or higher access level
- 2) Select the Menu > Configuration > Channel Settings and then select an IO module.
- 3) Select the required channel.
- 4) Select the screen that you want to edit (refer to previous sections of this manual).
- 5) Enter the required values in the field New Value and touch 'Finish'.
- 6) Review all parameters are valid and touch 'Apply'.
- 7) The system will return the new value; touch 'Update' to confirm.

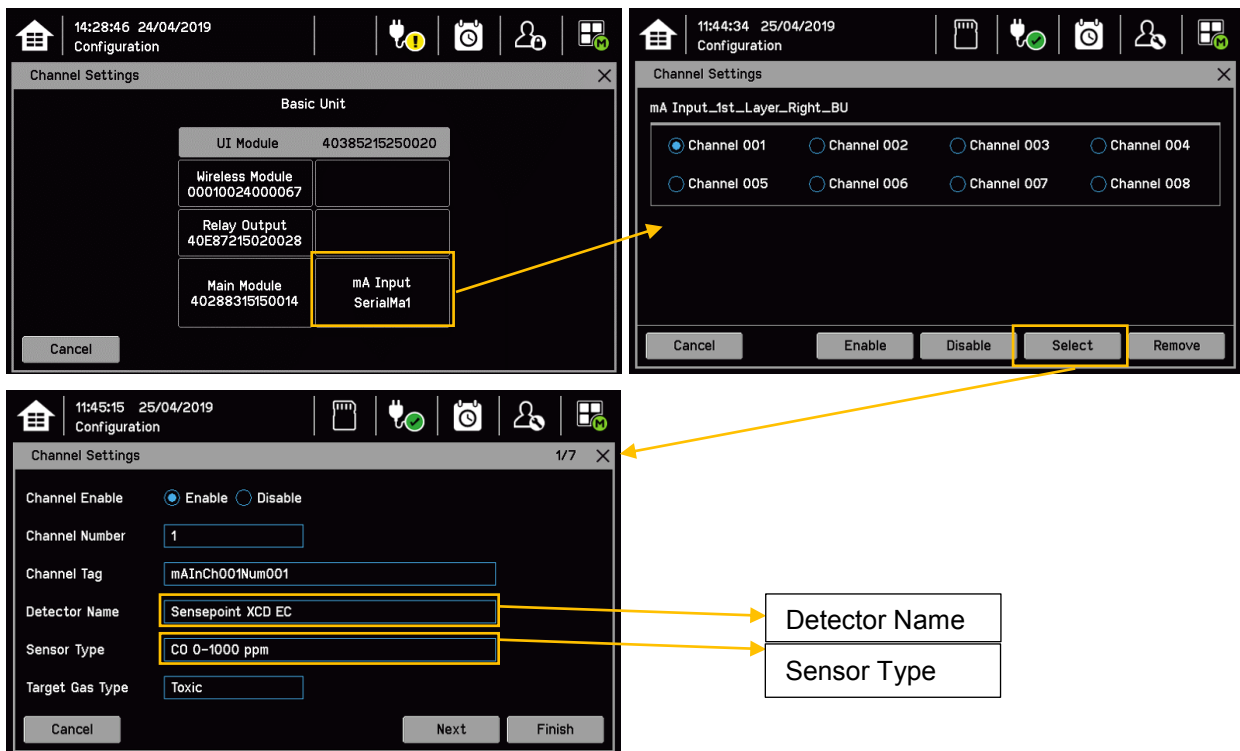

Note: Refer to Ch.14 Configurable Parameter Reference Guide for the list of available detectors. You can also use the TPPL Sensor Catalog to select listed gases, or you can enter 'User gas' details if respective gas is not listed.

Refer to Ch.8.6 How to Update the Sensor Catalogue for further information.

Commissioning

7.6.5 Configuring Wireless inputs

Note: You need to complete Network setting for wireless nodes.

To configure full scale of wireless nodes and tags:

- 1) Login as an Service or higher level
- 2) Select Menu > Configuration > Channel settings
- 3) Select required wireless module
- 4) Select "Wireless Detector" as device type
- 5) Select a detector and choose "Select"
- 6) Set full scales and tags

To configure a Wind sensor (if a RAEMet sensor is used)

- 1) Set Enable or Disable
- 2) Set Direction to trigger a condition in the chosen range
- 3) Set Speed to trigger a condition in the chosen setting
- 4) Set Duration to trigger a condition after the set period

CAUTION – FULL SCALE RANGE

User must set full scale range for every channel.
Trend graph is not available if full scale is not specified by user.
MODBUS register (30001~30064) data is not valid if full scale is not specified by user.

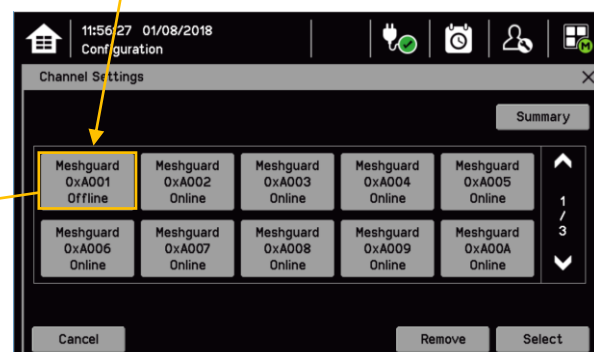
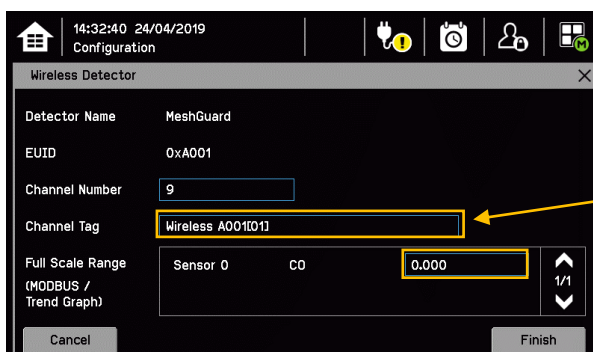
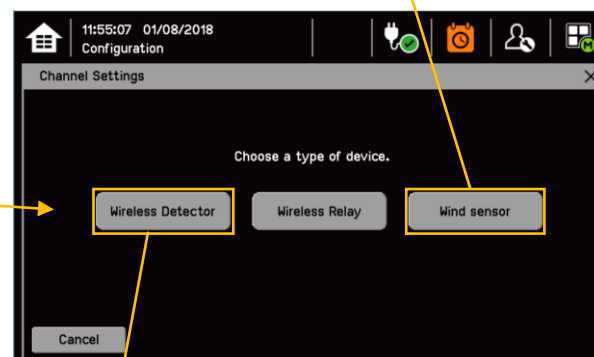
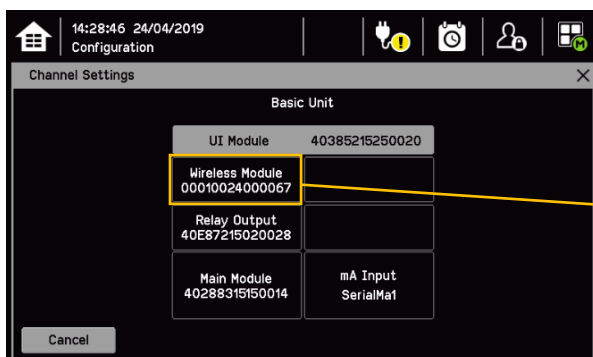
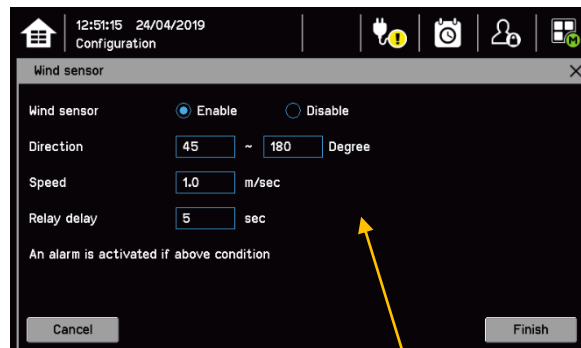

Commissioning

7.6.6 Configuring Relay Output Channels

Note: You need to complete Configuring analog input and wireless channels

Note: You need to complete Network setting for wireless nodes

To configure an individual channel:

- 1) Login as Service or higher level
- 2) Select Menu > Configuration > Channel settings
- 3) Select the required Relay Output Module
- 4) Select the required channel and confirm by touching 'Select'
- 5) Set Enable a channel
- 6) Select 'Assign type' to select among 'Sensor', 'Monitor' or 'Wind sensor', 'Digital In' or 'MANDOWN'.
- 7) Set others and touch 'Finish'
- 8) Check if all settings are correct and select 'Apply'
- 9) Check if all settings are correct and select 'Update'
- 10) Repeat steps 5 to 9 for all Relay channels



Commissioning

To configure an individual channel for MANDOWN events:

The screenshots illustrate the following steps:

- 14:17:00**: Selecting the 'Relay Output 40E87215020028' from the 'Basic Unit' configuration screen.
- 14:17:42**: Selecting 'Relay 1' from the 'Relay Output_2nd_Layer_Left_BU' screen.
- 14:22:59**: Choosing 'MANDOWN' as the 'Assign Type' for the relay channel.
- 14:18:22**: Configuring 'Relay Enable' (Enable), 'Relay Tag' (R0utCh003_Pt1), 'Assign Type' (Monitor), and 'Action Type' (Alarm 1).
- 14:23:44**: Selecting 'Panic' as the 'Action Type'.
- 14:26:17**: Configuring 'Relay Delay Time' (0 seconds), 'Relay Hold Time' (0 seconds), 'Relay Latch' (Disable), and 'Alarm Update Function' (Disable).
- 14:36:31**: Reviewing 'Assigned Monitors' (2 / 2 Selected) and setting the 'Vote' to 1.

CAUTION

Ensure that selected nodes feature Panic, Mandown and Super alarm events.

Commissioning

To configure an individual channel for Digital In events:



CAUTION

Ensure that selected nodes feature Digital Input (e.g. RigRat).

Commissioning

7.6.7 Configuring Wireless output

Note: Before configuring the Wireless Output, complete the Relay Output settings.

To configure a relay to mirror to wireless node relay:

- 1) Login as an Service or higher level
- 2) Select Menu > Configuration > Channel settings
- 3) Select the required Wireless Module
- 4) Select the 'Wireless Relay' as a device type
- 5) Select RAEpoint and touch 'Select'
- 6) Select a RAEpoint relay to be linked to TPPLW



Commissioning

7.6.8 Programming FA324

Power and Relay Wiring

It may be necessary to use an external power supply if fixed gas detectors are used within the same system.

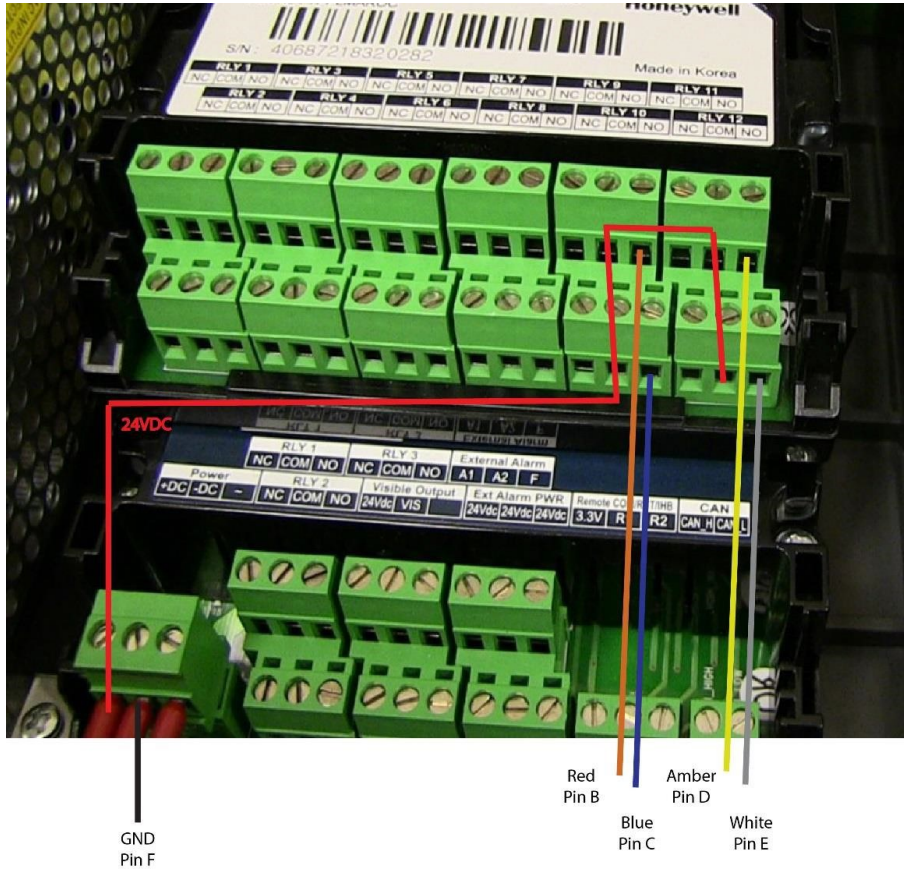

Pin	Wiring
A	No Connection
B	Power switch for Red light
C	Power switch for Blue light
D	Power switch for Amber light
E	Power switch for White light
F	Ground

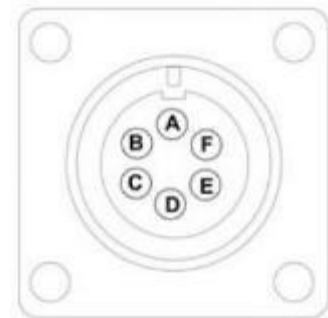

Programming steps

1. Login as Administrator
2. Go to Menu
3. Select "Configuration"
4. Select "Channel Settings"

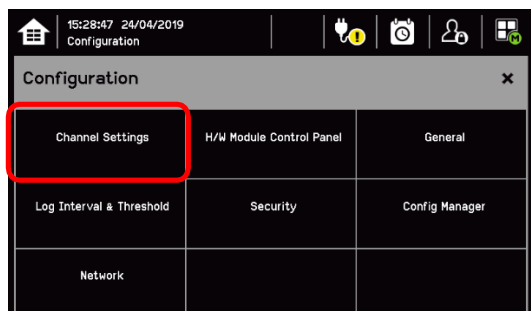
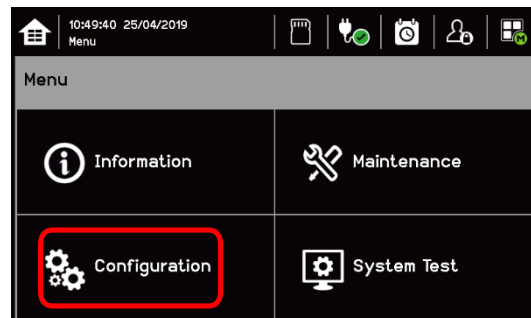

Commissioning

5. Select Relay Output

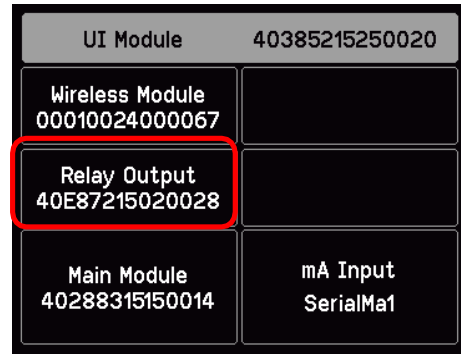

6. Select the desired Relay

- a. There are 12 relays to select from
- b. Relay Assignment is dependent on how the FA324 Alarm Bar connector is wired
- c. Assume the FA324 Alarm is wired to Relays 9, 10, 11 and 12
 - i. User is not limited to using relays 9 – 12
 - ii. Recommended: FA324 Alarm bar
 - Relay 9 – Red light
 - Relay 10 – Blue light
 - Relay 11 – Amber light
 - Relay 12 – White light

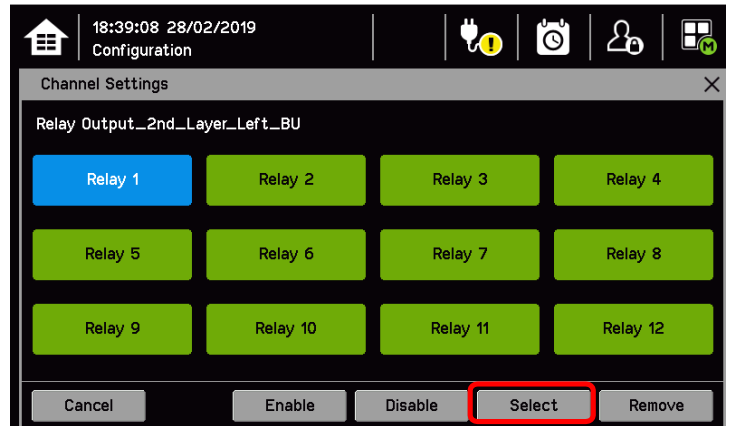

7. Tap on Select

8. Tap on Assign Type or Alarm Type

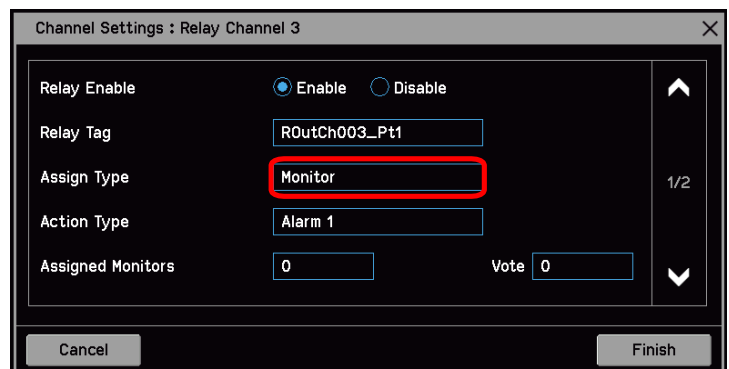

Commissioning

9. Choose Monitor for MeshGuard Detectors

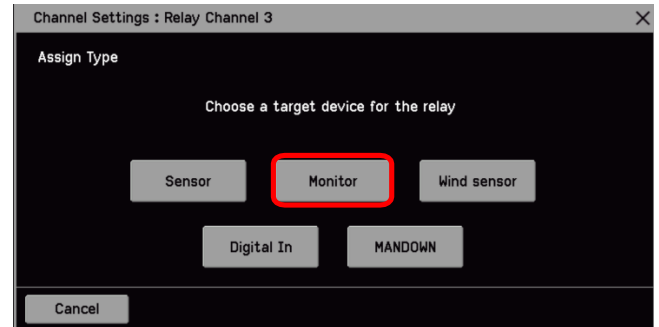

10. Select Alarm Type

- a. Alarm 1 – Low Alarm
- b. Alarm 2 – High Alarm
- c. Alarm 3 – High High Alarm,
Low Low alarm,
STEL/TWA alarm
- d. Fault
 - Low Battery
 - Negative
 - Offline
 - Overange

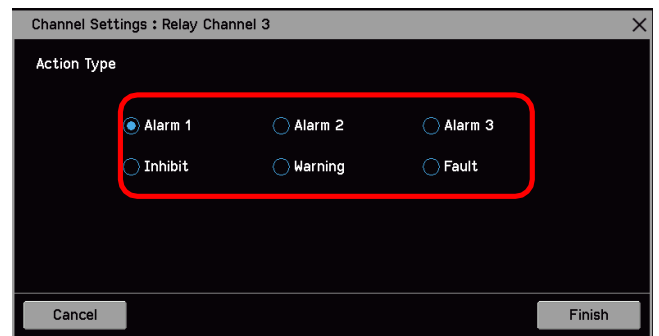

Note: 'Low' alarm, 'High' alarm, 'Low Low' alarm and 'High High' alarm are events related to RAE products (e.g., MeshGuard, MicroRAE and MultiRAE).

11. Assign Meshguard Detector to the relay

- a. Select All, or
- b. Check Include auto joining, or
- c. Select Individual Detector(s), or
- d. Select a Group of Detector Types
 - E.g., select all CO

Note: using EUI number or renaming each detector helps identify sensor type.

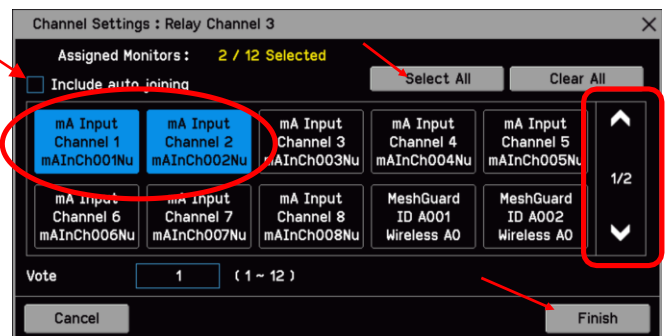

12. Tap on Finish

Commissioning

13. Note the Assigned Monitors value
14. Set Vote (if needed)
15. Page down to second page of Channel Setting screen
16. Set Relay Delay Time (if needed)
17. Set Relay Hold Time (if needed)
18. Set Relay Latch (if needed)
19. Set Update Function (if needed)
20. Select Finish when all conditions are set

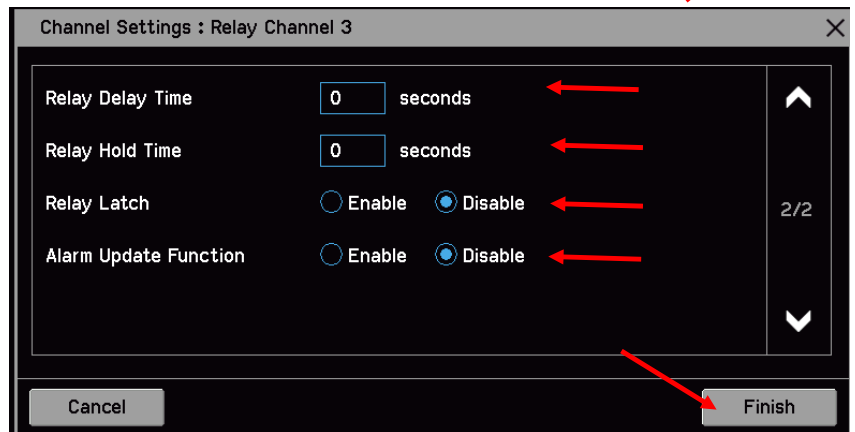
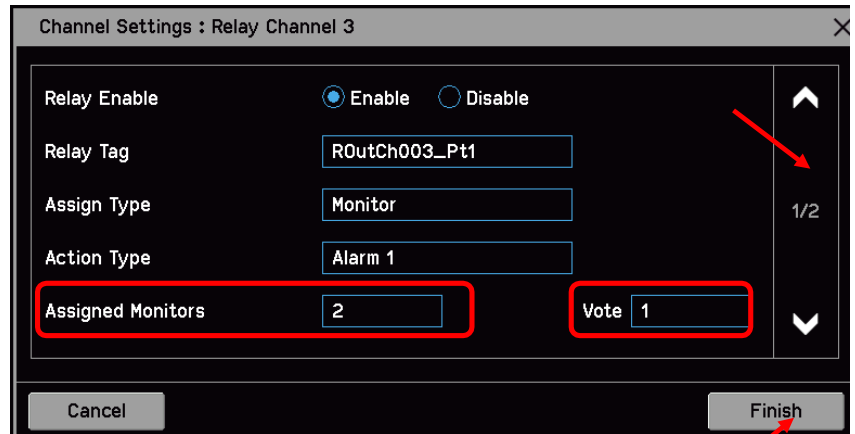

7.7 Data Logging

Set the Data Logging interval and threshold during configuration. A 0.0 %FSD threshold means that TPPLW will log the gas concentration at the specified intervals without checking in gas concentration. In contrast, a non-zero %FSD threshold setting will ignore fluctuations in low ambient gas concentrations and only check for rises in gas above the threshold (i.e. safe) setting.

Leave the setting at 0.0 to log gas concentration at the configured log interval. However, if you do want to monitor changes, you should start with a low threshold setting and slowly increase it by trial and error if you get too many unnecessary warnings.

Note: A low gas concentration %FSD reading at one sensor only applies to the area immediately surrounding that sensor, and may not indicate dangerous concentrations elsewhere in the room. Always consider using multiple sensors at differing heights and locations, be aware that sudden draughts can cause sharp rises in %FSD, and always take other safety measures (i.e. wearing Honeywell personal gas alarms) before entering or working in the monitored location.

Commissioning

To set or change Data Logging:

- 1) Log in as an Administrator or Service
- 2) Select Menu > Configuration > Log Interval & Threshold > mA Input and/or select Menu > Configuration > Log Interval & Threshold > Wireless Input
- 3) Select a box and enter the details using the touchpad
- 4) Select Finish
- 5) Make other changes or Log Out

7.8 Touch Panel Configuration

To access the panel configuration:

- 1) Login as Service or higher access level
- 2) Select the Menu > Configuration > Display.
- 3) Select LCD Backlight Timeout and Brightness settings, or Start to calibrate the Touch Panel (see below)
- 4) Select Finish to return to the Configuration menu

Access Level: Service

Parameter Name	Default Setting	Value Range	Comment
Backlight time out	30 seconds	30 seconds to 10 minutes or Always On	This is the time that the backlight will remain on after the touchscreen is idle. If a new event occurs, the backlight will come on and will remain on as long as the event remains unacknowledged.

7.8.1 How to Calibrate the Touch Panel

Calibrate the touch panel if the screen is not responding as expected.

To calibrate the screen:

- 1) Login as Service or higher access level.
- 2) Select the Menu > Configuration > Display.
- 3) Touch 'Start' next to Touch Panel Calibration.
- 4) Follow the instructions on screen.
- 5) Select Finish to return to the Configuration menu.

7.9 Service Contact Settings

To set the Service contact:

- 1) Login as Service or higher access level.
- 2) Select the Menu > Configuration > General > Service Contact.
- 3) Update the settings with your local service support contact details.
- 4) Select Finish to return to the Configuration menu.

Commissioning

7.10 Back up Configuration

Note: Service or higher access level is required for this procedure.

It is recommended you back up the Touchpoint Plus Wireless configuration once commissioning is completed.

To back up the configuration:

- 1) Take necessary precautions, then unscrew the handle security screws and open the enclosure door.
- 2) Ensure that an empty 2 to 32 GB (FAT32) standard SD Card with sufficient free space is inserted in the User interface module.
- 3) Login as an Service or higher
- 4) Select the Menu > Configuration > Config Manager > Export.
- 5) Enter file name for the backed-up configuration and Touch Finish.
- 6) Touch Export if the file name is valid. The backup may take several minutes, and progress is shown on screen.
- 7) When backup is completed, remove the card and immediately fit a spare card to record event data.
- 8) Close the enclosure door and tighten the two handle security screws.
- 9) Return the system to normal operation.
- 10) Transfer the backup data to a dated folder on a PC or digital device for safekeeping. The Configuration backup file is stored on the SD Card in '\\CFG\[filename.bin]
- 11) You can reuse the SD card once the data has been transferred to a PC or other device and deleted from the card.
- 12) Restoring a configuration is the reverse process, i.e. Import instead of Export, but it can only be done by an Administrator.

Note: The module configurations in the system should be same with ones when the configuration was exported. In other words module installation status and commissioning status should be same. If not the system will not import the previously exported configuration.

Commissioning

7.11 Calibrate mA Input Channel Loops

WARNING

Where the sensor / transmitter has the facility, the mA loop should always be calibrated at the Touchpoint Plus controller by forcing signal levels at the sensor / transmitter. Any gas calibration required must be carried out at the field device according to the manufacturer's instructions.

The Touchpoint Plus controller calibration should not be used to adjust for deficiencies in the sensor / transmitter gas calibration. Failure to observe this can result in significant accuracy errors.

Only trained technicians are authorized to carry out calibration

WARNING

Ensure that any relay activation (drenchers, repeater alarms, etc.) is inhibited before starting this test.

Note: Service or higher level access is required.

If the sensor is an Oxygen sensor that is not being used with a transmitter that has a force mA function, the span gas should normally be air at 20.9% v/v Oxygen.

The Touchpoint Plus Wireless controller calibration should not be used to correct deficiencies in the sensor calibration; instead carry out a gas calibration at the sensor according to the manufacturer's instructions.

To calibrate the mA loop of an input channel, follow the procedure below in combination with the relevant instructions in the sensor manual.

- 1) Login as Service.
- 2) Select the Menu > Maintenance > Gas Calibration. Select the channel to be calibrated.
- 3) Select 'Start' for Zero Calibration.
- 4) Apply zero gas to the sensor / field device so that it can generate 4mA signal.
- 5) View the reading until it is stable, and then touch 'Apply'.
- 6) Select 'Next' to move to the Span Calibration screen.
- 7) Enter the target span gas concentration and touch 'Apply'.
- 8) Select 'Start' for Span Calibration.
- 9) View the reading until it is stable, and then touch 'Apply'.

7.12 Calibrate Wireless Input Channel

1. TPPLW indicates disconnect state of the wireless channel when **local wireless node** is being calibrated.
2. TPPLW indicates disconnect state of the wireless channel when **portable products** are in menu mode.

Maintenance

Chapter 8 – Maintenance

This chapter describes how to perform common maintenance operations and upgrades. The required frequency of inspection and maintenance will depend on local site conditions and will need to be established through experience. Refer to IEC/EN 60079-29-2 or other local or national regulations for guidance on establishing an appropriate maintenance routine.

WARNING

Read Chapter 2 Safety before carrying out any work on the system.

WARNING

If the relays are switching mains voltages, hazardous live terminals may be present within the Relay Output Module even if the Touchpoint Plus system is isolated.
Ensure that all current is isolated and dissipated before touching live terminals.

8.1 Routine Maintenance

CAUTION

Test outputs will be generated and relays will be activated during the Cause and Effect Test.
Ensure that relay activated output systems (i.e. emergency deluge / sirens etc.) are isolated before starting the test.

CAUTION

While an Operator could Force a channel, an Engineer is required to isolate services, carry out tests, Clear Force, and restore the system to full operational status.
For these reasons Operators are advised to carry out visual inspections and cleaning only, unless under the direct supervision of the engineer.

8.1.1 Weekly Checks

- Visually inspect all cables and conduits.
- Check for loose connections, security of attachment, and signs of damage.
- Wipe the Touchpoint Plus Wireless Controller with a soft damp cloth or PC Screen cleaner.
- Check for dust contamination.
- Periodically exercise the relays to confirm functionality (see Caution above).

CAUTION

Do not use solvent or abrasives to clean any part of the Touchpoint Plus System.

Maintenance

CAUTION

When any of the test modes is active, the System Failure relay will activate to indicate that the safety function of the system is not operating.

8.1.2 Exercising the Relays

Relay output channels can be tested by forcing the relays to an active state:

- 1) Login as Service or higher level
- 2) Select the Menu > System test > Force Relay
- 3) Select the Relay module to be tested, and toggle it off and on for the specific Relay channel
- 4) Check the relay out contact using a voltage meter
- 5) Repeat steps 3 and 4 for all relay output channels

CAUTION

Ensure that the system is returned to normal operation once testing is complete.

8.1.3 Exercising Audio/Visual Alarm

Audio/visual alarm can be tested by forcing signal out:

- 1) Login as Service or higher level
- 2) Select the Menu > System test > Dedicated Alarm Contacts
- 3) Toggle it off and on for each outputs
- 4) Check the voltage level using a voltage meter

8.1.4 LCD Test

LCD touchscreen functionality can be tested:

- 1) Login as Service or higher level
- 2) Select the Menu > System test > LCD Test

8.1.5 LED and Buzzer Test

This test activates LEDs on the panel and the Buzzer:

- 1) Login with as Service or higher level
- 2) Select the Menu > System test > LED & Buzzer Test

8.1.6 Mesh Network Test

A Mesh network can be tested:

- 1) Login as Service or higher level
- 2) Select the Menu > System test > Mesh network > Ping test

Maintenance

8.2 Testing the Touchpoint Plus Wireless System

8.2.1 Introduction

The Touchpoint Plus Wireless system has two test modes available, which together enable a full test of the system. The test modes are:

- 1) Field Inputs Test – tests all input channel devices and alarm levels without affecting any outputs. Gas test, force mA, confirmation of correct device connection etc.
 - a) Login as Service
 - b) Set Inhibit Input Channels (only analog input is available)
 - c) Supply gases to the input channels
 - d) System will display gas reading and inhibit state
 - e) Pre-configured Inhibit Output (relays channels will output inhibit state) will be triggered and all alarm outputs will be inhibited

- 2) Cause and Effect Test – forces the Touchpoint Plus Wireless input channels to specific states to test that the correct output channels are activated.

WARNING

The Touchpoint Plus system is not operational while in Test Mode, under test will be ignored. Ensure that alternative safety arrangements are maintained during test, and ensure that Test Mode is exited as soon as testing is completed.

CAUTION

Test outputs conditions will be simulated and relays will be activated during the Cause and Effect Test. Ensure that relay activated output systems (i.e. emergency deluge / sirens etc.) are isolated before starting the test.

Once a test mode is active, the system will remain in test mode until the test is exited. The only exception is in the case of a power cycle of the Touchpoint Plus Wireless system, when it will restart in normal mode.

All events generated while the system is in test mode will be logged in the event history. Therefore a record of the testing can be generated once it is complete (see Normal Operation, Generate Reports).

CAUTION

Ensure that the system is returned to normal operation once testing is complete.

Maintenance

8.3 How to Replace a Faulty I/O Module

A faulty I/O module can be replaced with another of the same type, without needing to reprogram the configuration. Touchpoint Plus Wireless will automatically copy over the configuration to the new module.

WARNING

If the relays are switching mains voltages, hazardous live terminals may be present within the Relay Output Module even if the Touchpoint Plus system is isolated.
Ensure that all current is isolated and dissipated before touching live terminals.

ANTI-STATIC PRECAUTIONS

Antistatic Precautions are required to prevent severe damage to electronic components.

Note: Service or higher level access is required

Note: The new module must be the same type with same number of inputs/outputs as the old module.

- 1) Switch off the Touchpoint Plus Wireless (Menu > Maintenance > Power off)
- 2) Isolate the power supplies and switch off the battery if there is a back-up battery installed
- 3) Disconnect the faulty module
- 4) Replace the module
Note: Not required for WIO Module.
- 5) Reconnect the module
- 6) Switch on the battery if there is a back-up battery installed and switch on the Touchpoint Plus Wireless
- 7) Login as an Administrator
- 8) Select Menu > Configuration > HW Module Control Panel

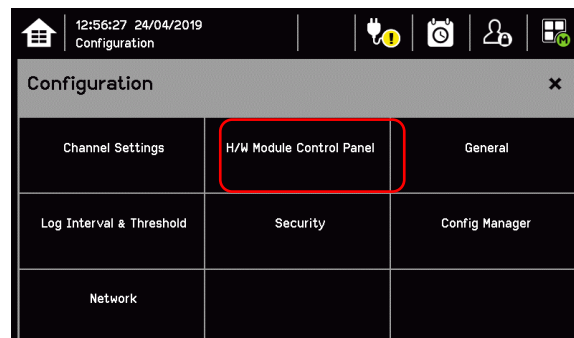
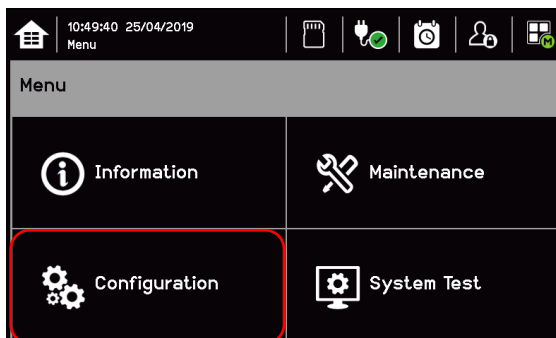

- 9) In the Board Control panel, select the empty blue block corresponding to the replaced module and touch 'Replace'

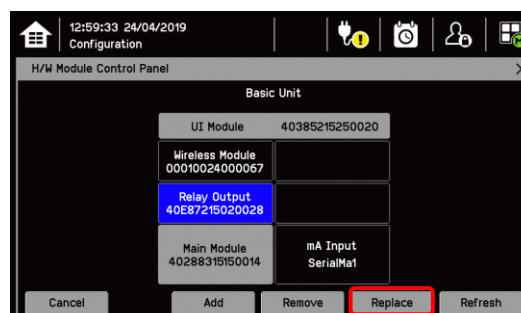

Maintenance

IO Module color:

Gray: The module cannot be added, removed or replaced because the module is mandatory.

Yellow: Module was added previously but no module is detected now (removed).

Sky blue: Serial number or module type does not match (IO Module is replaced).

Background color: Installed.

8.4 How to Add a New I/O Module

The Touchpoint Plus Wireless system can easily be expanded by adding new I/O modules.

ANTI-STATIC PRECAUTIONS

Antistatic precautions are required to prevent severe damage to electronic components.

Note: Service or higher level access is required

Note: A module which has previously been configured in one system cannot be added to another system, unless it was correctly removed from the original system's configuration.

- 1) Switch off the Touchpoint Plus Wireless (Select Menu > Maintenance > Power off)
- 2) Isolate power supplies
- 3) Fit the new module of the required type to an empty slot, ensuring that that the module is the correct way up and with the label towards you
- 4) Electrically connect the new module
- 5) Switch on the Touchpoint Plus Wireless
- 6) Login as an administrator
- 7) Select the Menu > Configuration > Module Control Panel
- 8) Select an empty block corresponding to the new module and touch 'Add'
- 9) Commission each channel in turn

Note: See Ch.7 Commissioning for detailed instructions for further information.

Maintenance

8.5 How to Remove or Decommission an I/O Module

WARNING

If the relays are switching mains voltages, hazardous live terminals may be present within the Relay Output Module even if the Touchpoint Plus system is isolated.

ANTI-STATIC PRECAUTIONS

Antistatic precautions are required to prevent severe damage to electronic components.

Note: Service or higher level access is required.

- 1) Login as an Administrator
- 2) Select Menu > Configuration > Module Control panel
- 3) Select the IO module block which is to be removed, and tap on 'Remove'
- 4) Switch off the Touchpoint Plus Wireless (Menu > Maintenance > Power off)
- 5) Isolate the Touchpoint Plus Wireless power supplies
- 6) Electrically disconnect the module, and then remove it
- 7) Switch on the Touchpoint Plus Wireless

8.6 How to Update the Sensor Catalogue

Note: Administrator access level is required

From time to time, new versions of the sensor catalogue will be released containing updates and new products from Honeywell Analytics.

To update the sensor catalogue in the Touchpoint Plus Wireless:

- 1) Create a new folder 'CATALOG' on an SD card
- 2) Copy the new sensor catalogue file 'SD car:\CATALOG\TPP_CAT.bin' into that folder
- 3) Insert a 2 to 32 GB (FAT32) standard SD card in the UI module
- 4) Login as an administrator
- 5) From the System Status screen select Menu > Maintenance > Update system > SensorCatalog
- 6) Confirm the update
- 7) The sensor catalogue file will be updated

Note: The update may take several minutes

Maintenance

8.7 How to Backup / Restore Configuration

CAUTION

You should always take a new back up of the Touchpoint Plus system configuration after changes are made and confirmed to be OK.

Service or higher level access is required to back up the configuration

Note: The Touchpoint Plus Wireless system remains available during this procedure.

- 1) If it is safe to do so, unscrew the handle security screws and open the enclosure door.
- 2) Ensure that an empty 2 to 32 GB (FAT32) standard SD Card is inserted in the User interface module.
- 3) Login as Service.
- 4) Select the Menu > Configuration > Config Manager > Export.
- 5) Enter file name for the backed-up configuration and Touch Finish
- 6) Touch '**Export**' if the file name is valid to start the configuration backup process. The backup may take several minutes, and progress is shown on screen.
- 7) When backup is completed, remove the card and immediately fit a spare card to record event data.
- 8) Close the enclosure door and tighten the two handle security screws.
- 9) Return the system to normal operation.
- 10) Transfer the backup data to a dated folder on a PC or digital device for safekeeping. The Configuration backup file is stored on the SD Card in 'SD card:\CFG\[filename].bin'
- 11) You can reuse the SD card once the data has been transferred to a PC or other device and deleted from the card.

Note: You cannot import configuration files if the I/O module configuration has changed since the last backup.

To restore the configuration:

- 1) Insert the SD card with 'SD card:\CFG\[filename].bin' into the UI module SD Card slot
- 2) Login as an Administrator
- 3) Select the Menu > Configuration > Config Manager > Import. Select a file.
- 4) Once the action is confirmed, the configuration restoration process starts and a progress message is displayed. The process may take several minutes depending on the system size.

Maintenance

8.8 How to Update Firmware

Firmware update is usually only carried out to fix a fault or to give a system upgrade. Firmware updates are usually optional and are not recommended if the system performs satisfactorily 'as is'.

Firmware and software updates should normally be carried out only by a Honeywell trained Engineer or an Engineer trained in accordance with this Technical Manual.

CAUTION

Touchpoint Plus Wireless firmware is NOT compatible with other product firmware such as Touchpoint Plus system.

CAUTION

Alternative site safety arrangements should be made during this procedure as the Touchpoint Plus system is **not** available during firmware updates, and they may take several minutes to complete.

CAUTION

Before starting the firmware update, confirm that the new User Interface module firmware is compatible with both the installed IO Module firmware and the Main module (see below).

Failure to do so may cause unexpected complications.

8.8.1 How to Check System Compatibility

- 1) Select Menu > Information > System information.
- 2) **Note** the firmware versions already installed.
- 3) Consult the Touchpoint Plus Wireless users support for compatibility information.
- 4) Contact your local service representative for advice if the new firmware is not compatible with the existing Modules.

8.8.2 How to Update the Firmware

CAUTION

A power cycle of the Touchpoint Plus Wireless system is required during this procedure.

Note: Administrator access level is required.

To update the Firmware:

- 1) Download the required Firmware to a PC or other device with an SD Card reader.
- 2) The Firmware is contained in the file 'SD card:\FW*.bin'. Copy this file to a standard 2 to 32 GB (FAT32) standard SD card (do not put it in a folder).
- 3) Ensure it is safe to do so, then unscrew the enclosure handle securing screws and pull the handle to open the door.
- 4) Remove the installed SD Card. Limited event logging will carry on internally for a short while, but some data may be lost if the update takes too long.

Maintenance

- 5) Insert the SD card containing the update file into the UI module.
- 6) Login as an administrator.
- 7) Select the Menu > Maintenance > Update system > Software.
- 8) Select a Module browse the appropriate firmware file in the SD card. Check the listed current and update versions. And touch 'Update' to continue
- 9) When the updates are completed, the system requires power reset.
- 10) Remove the SD card and refit the event logging SD card.
- 11) Close the door and secure the access handle.
- 12) Check that the system status is OK and no faults, inhibits or errors are shown.

8.9 How to Change the SD Card

Note: The system can accept standard SD cards from 2 to 32 GB (FAT32), and will provide a notification when the card is less than 50Mbyte free space.

To change the SD Card:

- 1) Ensure that it is safe to open the enclosure. Unscrew the two handle security screws and then pull the handle to open the enclosure door.
- 2) Select then Menu > Maintenance > SD Card > Eject.
- 3) When prompted, remove the SD Card and insert a replacement 2 to 32 GB (FAT32) card. Note the correct orientation in the picture below.
- 4) Confirm that the screen shows the SD Card as being correctly inserted and its usage is free space is sufficient
- 5) Close the access door and secure the locking handle.



Figure 36. SD Card Location

DANGER

Switch off and isolate power before inserting or removing SD card if used in a hazardous location, e.g. Class 1 Division 2

Maintenance

8.10 Back up Battery Maintenance

DANGER

Replace the battery pack with Honeywell Analytics part no. TPPLOIBB (order number: TPPLSIBB), and the PCB coin battery with type CR2032 only.

Use of other batteries may present a risk of fire or explosion.

DANGER

Lithium batteries may cause severe injury or death if put in the mouth or swallowed.

Always keep them away from children and dispose of them as hazardous waste.

CAUTION

According to local laws and regulations the battery installed within your product should be disposed of separately from household waste. When the battery reaches its end of life, take it to a collection point designated by local authorities.

Note: The DC 24 V battery pack has an integral 15 A over-current protection fuse, and will accept a nominal input charge of **24 – 32 VDC**. (<24 VDC will not charge the battery to the level required for backup power.)

8.10.1 Recommended Scheduled Maintenance

- Visually inspect the Touchpoint Plus Wireless Battery and (as the enclosure is open) all cabling.
- Check for signs of damage, deterioration, or loose connections.
- Periodically check that the cooling vents have not become obstructed.

8.10.2 How to Replace the Battery Pack

DANGER

Touchpoint Plus shall not be operated with the access door unsecured when in Normal mode. Failing to secure it properly will risk fire or explosion and will invalidate Regulatory Approval.

The battery pack has circuitry that puts it into sleep mode to save power when it is not connected and running. Connecting it to a powered-up Touchpoint Plus Wireless causes the battery to change to active mode and it will function normally after a short booster charge.

To replace the battery pack:

- 1) Ensure that the atmosphere is below flammable levels.
- 2) Leave the Touchpoint Plus Wireless Controller powered on.
- 3) Unscrew the two locking handle security screws and open the enclosure.
- 4) Switch the backup battery On/Off switch to **Off** (Fig. 31) to isolate the battery.
- 5) Replace the battery pack with Honeywell Analytics part no. TPPLOIBB (order number: TPPLSIBB)
- 6) Switch the backup battery On/Off switch back to **On**.

Maintenance

- 7) Close the enclosure door and secure the handle with the two security screws.



Figure 37. Battery On/Off Switch and Battery Connector

Note: Ensure that the battery On/Off switch is in the **On** position before closing the access door or the backup battery will not work when it is most required.

8.11 Return to Factory Setting

Note: Admin level access is required

User can reset all TPPLW user configuration setting to factory setting

- 1) Log in as Admin
- 2) Select Maintenance > Service Mode > Reset to Default

WARNING

All mA input channel gas calibrations, Relay output setting will be initialized.

CAUTION

Passwords are not changed by Reset to Default.

CAUTION

All I/O modules must be added in HW Module Control Panel menu again. Refer to the Ch.8.4 How to add a new I/O Module.

Troubleshooting

Chapter 9 – Troubleshooting

WARNING

Read **Chapter 2 Safety**
before carrying out any work on the gas detection systems.

Problems are signalled by an error code shown on the control panel display. The error is recorded in the event log and the screen can be cancelled once the fault is corrected.

The error messages are explained in Chapter 16: Fault Codes.

Contact Honeywell Analytics Technical Support if an error appears repeatedly, if it cannot be cleared, or if it is not listed in Chapter 16: Fault Codes.

9.1 Calling for Technical Support

Contact Honeywell Analytics Technical Support if your problem cannot be resolved or if you need additional help. You can find our contact details on the rear cover of this manual.

To assist the Honeywell Helpdesk in giving you technical support, it would be helpful to have the following information ready:

- Your Company contact details and a contact name and department.
- The system model type, i.e. Touchpoint Plus Wireless, and its serial number. These can be found on the system identification label.
- The software version found under the **System Info** menu option key.
- Details of the difficulty that you are experiencing.
- Error message and code numbers that were shown on the display screen.

To assist with the fault diagnosis you may be asked to send a copy of your event log by email.

Technical Specifications

Chapter 10 – Technical Specifications

10.1 Environmental

Sealed enclosures are rated IP65, NEMA 4x, and can be installed indoors only in a Pollution Degree 2, 10 to 95 %RH Non-Condensing environment that affords total protection from rain, snow and direct sunlight.

Operating Temperature	-10 °C to + 55 °C certified range
Storage Temperature	-25 °C to + 60 °C
Operating Humidity (closed)	10 to 90 %RH (non-condensing)

10.2 User Interface and Main Module

LCD Touch Screen Type	7" TFT Colour LCD with LED Backlight (resistive touch screen) 800 x 480 pixels (WVGA) Resolution Active area 155.08 mm (H) x 86.92 mm (V)
Front Display	Green Power LED
	Red Alarm LED
	Yellow Fault/inhibit LED
	Alarm Mute /Reset Push Button
	Alarm Buzzer (Sound Level: 70 dB at 1 m)
Communication Outputs	1) 10/100 Mbps Ethernet Interface with standard RJ-45 connector 2) RS-485 Modbus connections supporting 115.2 kbps max.
Output Relays	Two configurable and one fixed System State Relays: 1.7 A @ 250 VAC, 1.7 A @ 30 VDC (non-inductive load)
Dedicated Audio and Visual alarm	Four outputs to external devices Supply voltage Vs (18 – 32 VDC) –1.8* VDC (max), max 300 mA per channel *Voltage drop at ambient temperature
Remote Terminals	Optional remote acknowledge, reset and inhibit
Module Power Consumption	4.4 W for User interface module and Main Module (Max 33.2W @ Audio/Visual Alarm device connected)

Technical Specifications

10.3 I/O Modules

10.3.1 mA Input Module

Description	8-channel Analogue Input Module for 2-wire or 3-wire 4 – 20 mA detector signals
Sensor Configuration	2-wire or 3-wire current source
Signal Measurement Range	0 – 24 mA
Sense Resistance	66 Ω
Module Power Consumption	Max 0.4 W (Excludes power to mA detector)
Field Device Power Supply Vmax (---)	Supply voltage Vs (18 – 32 VDC) – *1.8 VDC (max) *Voltage drop in Touchpoint Plus Wireless
Field Device Power Supply Power max (single channel)	20 W
Field Device Power Supply Power max (eight channels)	40 W
Maximum cable length for mA Input loop (Rloop)	$R_{loop} = (V_{controller} - 1.8 \text{ VDC} - V_{detector \text{ min}}) / I_{detector}$ Maximum Cable run length = $R_{loop} / (\Omega \text{ per metre})$ Example: $V_{controller} = 24 \text{ VDC}$, TPP Voltage drop = 1.8 VDC, $V_{detector} = 18 \text{ VDC}$ (18 to 32 VDC), $I_{detector}$ = From detector specification.

10.3.2 Relay Output Module

Description	12-channel Relay Output Module incorporating 12 single pole change over (SPDT) relays
Power Consumption Maximum	2.5 W (with all relays energised)
Relay Contacts (~ / ---)	1.7 A @ 250 VAC / 17A @ 30 VDC,
Relay Operation	Individually configurable for – normally energised / de-energised operation

10.3.3 Wireless Module

Description	64 wireless node connection without RAEMet
Power Consumption Maximum	1.2 W (with RAEMet)
Wireless	2.4 GHz or sub 1 GHz IEEE 802.15.4/ mesh radio

Technical Specifications

10.4 Power Supplies

10.4.1 External Supplies

SMPS Power Supply	156 W
AC Input Voltage Range (~)	AC 110/220 V ± 10 % of nominal (manual switching)
DC Input Voltage Range (—)	DC 18 – 32 V SELV Supply
Input Frequency Range (~)	AC 50 – 60 Hz ± 6 %
Output Voltage (—)	DC 24 V
Dimension	199 x 98 x 38mm (L x W x H)

10.4.2 Backup Battery

Description	22.2 V Lithium - ion Battery, 2600mAh
Dimensions/Weight	124.8 x 78.9 x 29.2 mm, 425g
Operating Temperature	0 – 50 °C
Operating Humidity	10 to 90% RH (non-condensing)
Storage Life Limitations	1 year: –20 °C to +25 °C (–4 °F to +077 °F) 3 months: –20 °C to +45 °C (–4 °F to +113 °F) 1 month: –20 °C to +60 °C (–4 °F to +140 °F)
Storage Lifetime without re-charge	1 year
Input Current (charging) (—)	DC 24 – 32 V @ 0.25 mA max.
Output Voltage (when supplying) (—)	17.4 – 25.2 VDC
Maximum Input Current	250 mA

10.5 Enclosures

10.5.1 Wall Mount Enclosure

Material	PC ABS
Cable Gland Plug	PG16
Environmental Protection	IP65 (when fully closed and locked), NEMA 4x indoor
Operating Humidity	10 to 90 %RH (non-condensing)
Mounting Bracket – Dimension	W 423 x D 325 x H 16.5 mm, 1.5 kg (approx)
Weight	8.5kg
Dimension	426 mm x 300 mm x 156 mm (16.9 ins x 11.8 ins x 6.2 ins)

Certifications

Chapter 11 Certifications

11.1 EC Declaration of Conformity

A full EC declaration of conformity is available on either original hardcopy or electronic file (Honeywell Analytics website). This document lists the European Standards with which Touchpoint Plus Wireless complies.

WARNING

Only the combustible gas detection portion of this instrument has been assessed for performance in accordance with the ATEX Directive.

AVERTISSEMENT

Seulement la partie détection de gaz explosif de cet équipement a fait l'objet de tests de performance métrologique suivant la directive ATEX.

WARNING

CSA performance is only valid when connected to Honeywell Model 705 Catalytic Gas Detectors or suitably approved 4 – 20 mA Gas Detectors.

AVERTISSEMENT

La performance en conformité avec la CSA est valide uniquement lorsque l'appareil est connecté aux détecteurs de gaz catalytiques Honeywell modèle 705 ou à des détecteurs de gaz 4 - 20 mA dûment approuvés.

Certifications

11.2 National and International Certificates of Compliance

The Touchpoint Plus Wireless Process Control Equipment holds the following National and International Certificates and Certification Codes:

Title	Standards	Certificates
Ingression protection	IP65	
Hazardous Locations (Non-Incendive)	Class 1, Division 2, Group A, B, C, D, Temp. Code T4 UL 121201, CAN/CSA C22.2 No. 213-17	UL File E480011
Electrical Safety	UL/IEC/EN 61010-1 CSA C22.2 No.61010-1-12/No.142, and UL 508	UL File E466771, E470577 and E480011
EMC/RFI	EMC Directive (EN 50270:2015)	
Battery Pack	UN 38.3 (IEC 62133), UL 2054, UL 60950-1 and CSA C22.2 No.60950-1-07	UL File MH60522
Low Voltage Directive	IEC/EN 61010-1 (3rd Edition)	
Wireless	FCC 15C, IC RSS-247 2.4 GHz and sub 1 GHz	
Performance	CSA 22.2 No. 152-M1984	UL File E480011

WARNING

Ambient temperature: Dependent on components fitted, check individual rating plates.

FA324 is not available in Class 1 Division 2.

AVERTISSEMENT

Température ambiante : elle dépend des composants assemblés, vérifier individuellement les plages de température.

FA324 n'est pas disponible en Classe 1 Division 2.

Replacement Parts and Optional Extras

Chapter 12 Replacement Parts and Optional Extras

The following replacement parts and optional extras are available to order, but Honeywell Analytics cannot accept responsibility for their incorrect fitment or use.

All Honeywell supplied replacement parts are covered by the standard Honeywell warranty service.

With the exception of SD Cards, the equipment listed below is only to be installed or replaced by the Manufacturer's trained personnel, or by competent persons trained in accordance with the Manufacturer's installation instructions.

CAUTION

Do NOT interchange *Touchpoint Plus Wireless* parts with *Touchpoint Plus* parts as they are NOT compatible.

Description	Part Number
TPPLW, DC power, 2.4 GHz, 12 relays	TPPLWDANNSNNNN
TPPLW, DC power, 2.4 GHz, 8ch 4-20 mA, 12 relays, Battery, MODBUS	TPPLWDAA8SNBRT
TPPLW, AC power, 2.4 GHz, 12 relays, Battery, MODBUS	TPPLWAANNSNBRT
TPPLW, AC power, 2.4 GHz, 8ch 4-20 mA, 12 relays, Battery, MODBUS	TPPLWAAA8SNBRT
TPPLW, DC power, 868 MHz, 12 relays	TPPLWDBNNSNNNN
TPPLW, DC power, 868 MHz, 8ch 4-20 mA, 12 relays, Battery, MODBUS	TPPLWDBA8SNBRT
TPPLW, AC power, 868 MHz, 12 relays, Battery, MODBUS	TPPLWABNNSNBRT
TPPLW, AC power, 868 MHz, 8ch 4-20 mA, 12 relays, Battery, MODBUS	TPPLWABA8SNBRT
TPPLW, DC power, 869 MHz, 12 relays	TPPLWDCNNSNNNN
TPPLW, DC power, 869 MHz, 8ch 4-20 mA, 12 relays, Battery, MODBUS	TPPLWDCA8SNBRT
TPPLW, AC power, 869 MHz, 12 relays, Battery, MODBUS	TPPLWACNNSNBRT
TPPLW, AC power, 869 MHz, 8ch 4-20 mA, 12 relays, Battery, MODBUS	TPPLWACA8SNBRT
TPPLW, DC power, 865.6 / 865.4 MHz, 12 relays	TPPLWDDNNSNNNN
TPPLW, DC power, 865.6 / 865.4 MHz, 8ch 4-20 mA, 12 relays, Battery, MODBUS	TPPLWDDA8SNBRT
TPPLW, AC power, 865.6 / 865.4 MHz, 12 relays, Battery, MODBUS	TPPLWADNNSNBRT
TPPLW, AC power, 865.6 / 865.4 MHz, 8ch 4-20 mA, 12 relays, Battery, MODBUS	TPPLWADA8SNBRT
TPPLW, DC power, 900 MHz, 12 relays	TPPLWDENNSNNNN
TPPLW, DC power, 900 MHz, 8ch 4-20 mA, 12 relays, Battery, MODBUS	TPPLWDEA8SNBRT
TPPLW, AC power, 900 MHz, 12 relays, Battery, MODBUS	TPPLWAENNSNBRT
TPPLW, AC power, 900 MHz, 8ch 4-20 mA, 12 relays, Battery, MODBUS	TPPLWAEA8SNBRT

Replacement Parts and Optional Extras































Description	Part Number
SD Card (2 to 32 GB) FAT32 standard format	Local purchase
SD Card (8 GB)	TPPLOSDC
Backup battery pack	TPPLSIBB
TPPLW Input Module 8 Channel mA	TPPLWSMAAI8
TPPLW Output Module 12 Channel Relay	TPPLWSMAROC
TPPLW Main Module	TPPLWSMPM
SMPS (150 W,110 / 220 VAC)	TPPLSSAM
Back Plane PCB Assembly	TPPLSBPM
TPPLW UI PCB	TPPLWSDPM
TPPLW Touch Screen LCD	TPPLSLTSM
External Strobe	M-700123
Cable gland	TPPLOGLD
Metal grounding for cable gland	TPPLOMGND
TPPLW Wall Mounting Bracket	TPPLOWMB
TPPLW Bipole antenna (2.4 GHz)	TPPLWOANT
TPPLW Sub 1 GHz Antenna	TPPLWOANT2
TPPLW Antenna cable 10 m	TPPLWOCBL
TPPLW Lightning arrest	TPPLWOSRT
TPPLW Wireless I/O module	TPPLWSMAWIO
TPPLW Wind sensor and mounting kit	TPPLWOWS
FA324 connection kit	TPPLWOF324
TPPLW UI PCB Module, MODBUS (Service Part)	TPPLWSDPMRT
TPPLW 10 meter cable for Wind Sensor	TPPLWOWSCBL
TPPLW Wireless I/O module, 2.4 GHz (Service Part)	TPPLWSMAWIO
TPPLW Wireless I/O Module, 868 MHz (Service Part)	TPPLWSMAWIOB
TPPLW Wireless I/O Module, 869 MHz (Service Part)	TPPLWSMAWIOC
TPPLW Wireless I/O Module, 865.6 / 865.4 MHz (Service Part)	TPPLWSMAWIOD
TPPLW Wireless I/O Module, 900 MHz (Service Part)	TPPLWSMAWIOE

Glossary of Icons





























Chapter 13 – Glossary of Icons

#	Icon	Description	#	Icon	Description
1		Tile View	16		Login Administrator
2		Summary View	17		Menu, System OK
3		History Information	18		AC Power
4		History Alarm	19		Battery Power
5		History Fault	20		SD Card inserted
6		History Inhibit	21		SD Card fault
7		History Warning	22		Zoom In
8		History Default	23		Zoom Out Scroll
9		Login None	24		Calibration
10		Login not Selected	25		Configuration
11		Login Operator	26		Peak Reset
12		Login Operator Select	27		Trend
13		Login Maintainer	28		Inhibit
14		Login_ Maintainer_select	29		Location
15		Login Maintainer	30		Filter_Information
			31		Icon empty





















Glossary of Icons

#	Icon	Description	#	Icon	Description
32		Cancel	47		Pop Up for Alarm
33		Processing OK	48		Pop Up for Error
34		Processing FAIL	49		Pop Up for Fault
35		Processing OK	50		Pop Up for Inhibit
36		Processing FAIL	51		Pop Up for Warning
37		Item Select	52		Pop Up for Information
38		Item Select	53		System Setting Menu
39		List Up	54		Configuration Menu
40		List Down	55		Maintenance Menu
41		Yellow Button-Up	56		Information Menu
42		Yellow Button-Down	57		Purge Animation
43		Yellow Button-Up	58		Purge Animation
44		Yellow Button-Down	59		Purge Animation
45		Gray Button-Up	60		Base Line
46		Gray Button-Down	61		Gas Calibration

Glossary of Icons

#	Icon	Description	#	Icon	Description
62		Factory Calibration	76		Language_Italian
63		Factory Calibration	77		LCD Setting
64		Factory Calibration	78		Boot-up logo
65		Critically Low Battery	79		Online monitor fault
66		Critically Low Battery	80		Wireless Node Online
67		Power Off View	81		Wireless Node Offline
68		Language_English	82		Wireless Node Router Mode
69		Language_Chinese	83		Wireless Node Battery Level
70		Language_French	84		Wireless RSSI
71		Language_German	85		Wireless Node Configuration
72		Language_Dutch	86		Wireless GPS Data
73		Language_Spanish	87		Wireless Node Remove
74		Language_Russian	88		Wireless Detector Sensor - Low Alarm
75		Language_Portuguese	89		Wireless Detector Sensor - High Alarm

Glossary of Icons

#	Icon	Description	#	Icon	Description
90		Wireless Detector Sensor – Over Range	106		Wind direction 180 °
91		Wireless Detector Sensor - STEL Alarm	107		Wind direction 225 °
92		Wireless Detector Sensor - TWA Alarm	108		Wind direction 270 °
93		Wireless Detector Sensor - LowLow Alarm	109		Wind direction 315 °
94		Wireless Detector Sensor - HighHigh Alarm			
95		Summary Alarm			
96		Filter for Event			
97		Left screwing view			
98		Right screwing view			
99		Left-Previous screen			
100		Right-Next screen			
101		Pause view screwing			
102		Wind direction 0 °			
103		Wind direction 45°			
104		Wind direction 90 °			
105		Wind direction 135 °			

Configurable Parameter Reference Guide

Chapter 14 Configurable Parameter Reference Guide

Module	Name	Description	Read/Write	Range	Default Value	Remark
mA Input	Channel Enable	Channel Enable/Disable	R/W	Disable/Enable	Disable	0
mA Input	Channel Number	Number	R/W	1~73	-	A unique number for every channel 1~8 LED for analog input. Auto assigning for wireless node
mA Input	Channel Tag	50 characters	R/W	Alphanumeric Character Range	50 chars	0
mA Input	Detector Name	40 characters	R/W	Alphanumeric Character Range	40 chars	Write available when: Detector Name- User Detector
mA Input	Target Gas Name	16 characters	R/W	Alphanumeric Character Range	16 chars	Write available when: Detector Name- User Detector
mA Input	Target Gas Unit	mg/m3, g/m3, %VOL, ppm, %LEL, UEG, Ratio, %LEL x M, ppm x m, EG x m, %Vol x m, LEL.m, LEL%.m, %V/V, mA, kppm, oC, oF, %RH User (6chars)	R/W	Alphanumeric Character Range	%	Write available when: Detector Name- User Detector
mA Input	Target Gas Digit	Number of decimal point	R/W	0~3	1	0
mA Input	Target Resolution	Display Resolution	R/W	0.001~100	0.1	0.001, 0.002, 0.005, 0.01, 0.02, 0.05, 0.1, 0.2, 0.5, 1, 2, 5, 10, 20, 50, 100
mA Input	Gas Type	Gas Type	R/W	Toxic/O2/Flammable/Flame	Gas Type	Depend on Gas Name. Toxic(0) O2(1) Flammable(2) Flame(3)
mA Input	Inhibit Time-out	Inhibit Time-out	R/W	0~60	10	0: Disable, minute
mA Input	Alarm Latch	Set alarm latch enable/disable	R/W	Disable/Enable	Enable	per channel, Unused Data
mA Input	Calibration Interval	0, 30 to 365	R/W	0.30 to 365	180	0 : Disable

Configurable Parameter Reference Guide

Module	Name	Description	Read/Write	Range	Default Value	Remark
mA Input	Target Full Range	Min full range, Max full range and user	R/W	0~100000	Max full range	Write available when: Detector Name- User Detector. Max range in catalogue file
mA Input	Threshold Alarm Hysteresis	Set hysteresis for alarm 1,2,3	R/W	0~10	2% of Full range	
mA Input	Alarm 1 Enable	Set alarm 1 enable/disable	R/W	Disable/Enable	Disable	0
mA Input	Alarm 1 Threshold Trigger	Set alarm 1 direction Rising/Falling	R/W	Rising/Falling	Rising	0
mA Input	Alarm 1 Level	Set alarm 1 level	R/W	2%FSD ~ 100%FSD	20% of Full range	0
mA Input	Alarm 2 Enable	0	R/W	Disable/Enable	Disable	0
mA Input	Alarm 2 Threshold Trigger	0	R/W	Rising/Falling	Rising	0 Rising, 1 Falling
mA Input	Alarm 2 Level	0	R/W	2%FSD ~ 100%FSD	40% of Full range	0
mA Input	Alarm 3 Enable	0	R/W	Disable/Enable	Disable	0
mA Input	Alarm 3 Threshold Trigger	0	R/W	Rising/Falling	Rising	0
mA Input	Alarm 3 Level	0	R/W	2%FSD ~ 100%FSD	60% of Full range	0
mA Input	STEL Interval	Set STEL period 10, 15, 20, 25, 30	R/W	10, 15, 20, 25, 30	15	Minute
mA Input	Lower Zero Dead Band	Set lower deadband limit to display Zero	R/W	-20 ~ 0 % FSD	0	O2 : 20.9%
mA Input	Upper Zero Dead Band	Set upper deadband limit to display Zero	R/W	0 ~ 20% FSD	0	O2 : 20.9%
mA Input	Gas Over Range Limit	Set limit to trigger gas over range event	R/W	100% ~ 125%FSD	110 %FSD	0
mA Input	Gas Under Range Limit	Set limit to trigger gas under range event	R/W	-24% ~ 0%FSD	-10 %FSD	0
mA Input	Span Calibration Conc.	Set a target span gas Conc.	R/W	15 ~ 100 %FSD	50% of Full range	Oxygen needs just span calibration. No zero calibration required.
mA Input	Signal Under Range Limit	Set limit to trigger signal under range event	R/W	0	0	To diagnose the mA input current

Configurable Parameter Reference Guide

Module	Name	Description	Read/Write	Range	Default Value	Remark
mA Input	Signal Over Range Limit	Set limit to trigger signal over range event	R/W	20~24mA	Depend on detectors	To diagnose the mA input current The mA value of sensor fault code 6 varies in 20 - 24 mA for the sensor installed. In the case of user detector setting, the mA value of sensor fault code 6 is fixed to 24 mA.
mA Input	Signal Inhibit Min.	Set minimum inhibit current from mA output sensor	R/W	0~24	1.9 mA	if min/max is set to zero, mA input board will not detect inhibit condition.
mA Input	Signal Inhibit Max.	Set maximum inhibit current from mA output sensor	R/W	0~24	2.1 mA	0
mA Input	Signal Fault Min.	Set minimum fault current from mA output sensor	R/W	0~24	0.0 mA	if min/max is set to zero, mA input board will not detect fault condition.
mA Input	Signal Fault Max.	Set maximum fault current from mA output sensor	R/W	0~24	1.1 mA	0
mA Input	Signal Warning Min.	Set minimum warning current from mA output sensor	R/W	0~24	2.9 mA	if min/max is set to zero, mA input board will not detect warning condition.
mA Input	Signal Warning Max.	Set maximum warning current from mA output sensor	R/W	0~24	3.1 mA	0
mA Input	Alarm 1 Function	Threshold, STEL, TWA	R/W	0~2	Threshold	Threshold=0, STEL=1, TWA=2
mA Input	Alarm 2 Function	Threshold, STEL, TWA	R/W	0~2	Threshold	Threshold=0, STEL=1, TWA=2
mA Input	Alarm 3 Function	Threshold, STEL, TWA	R/W	0~2	Threshold	Threshold=0, STEL=1, TWA=2
mA Input	Target Zero Range	Set to a level to display Zero	R/W	-100000~100000	0	Write available when: Detector Name- User Detector.

Module	Name	Description	Read/Write	Range	Default Value	Remark
Relay Output	Channel Enable	Channel Enable/Disable	R/W	Disable/Enable	Disable	0
Relay Output	Channel Number	Number	R	1~73	-	A unique number for every channel 1~8 LED for analog input. Auto assigning for wireless node

Configurable Parameter Reference Guide

Module	Name	Description	Read/Write	Range	Default Value	Remark
Relay Output	Channel Tag	25 characters	R/W	Alphanumeric Character Range	50 chars	
Relay Output	Normal State	Energized/ De-energized	R/W	Energized/ De-energized	Energized	0
Relay Output	Alarm Update Function	If enabled, only unacknowledged alarm conditions will be considered during C&E evaluation for this output channel. An alarm acknowledgement will reset a relay output that is configured for alarm update function. However if the alarm update is NOT enabled the relay contact will only be reset if the alarm is reset.	R/W	Enable/ Disable	Disable	0
Relay Output	Active Delay Time	Delay time to activate the relay	R/W	0~3000	0 sec	Second
Relay Output	Relay Hold Time	Delay time to de-activate the relay	R/W	0~3000	0 sec	Second
Relay Output	Relay Latch	Relay Latch	R/W	Enable/ Disable	Disable	0
Relay Output	Event Type	Event type - Alarm, Fault, Warning, Inhibit	R/W	Alarms, Fault, Inhibit, Warning	-	Alarm1(1), Alarm2(2), Alarm3(3), Fault(4), Inhibit(5), Warning(6)
Relay Output	Event Source Type	Detector, Sensor, WindSensor	R/W	0~2	-	Detector(0), Sensor(1), WindSensor(2)
Relay Output	Gas Index	Gas index number of wireless detector	R/W	1~76	-	1~76
Relay Output	Vote Count	Occurred event count. Only to use to detector type	R/W	1~255	1	1~255
Relay Output	Reserved	-	R/W	0	0	0

Module	Name	Description	Read/Write	Range	Default Value	Remark
WIO Module	Channel Enable	Channel Enable/Disable	R	Disable/Enable	Disable	0

Configurable Parameter Reference Guide

Module	Name	Description	Read/Write	Range	Default Value	Remark
WIO Module	Channel Number	Channel Enable/Disable	R	9~72	–	0
WIO Module	Channel Tag	25 characters (/wo NULL)	R/W	Alphanumeric Character Range	"Wireless Node " + Node ID	0
WIO Module	Module Index	Wireless Module index	R	1~7	–	Board Position
WIO Module	Node Address	Node's Modem transmission address	R	0x0010~0xFEFF	0	0
WIO Module	Instrument ID	Detector's Product ID	R	Alphanumeric Character	–	refer to 904-E800-202 ID Definitions for RAE Instruments.doc
WIO Module	Serial Number	Detector's Serial Number	R	13 chars	–	0
WIO Module	Firmware Version	Detector's Firmware Version	R	7 chars	–	0
WIO Module	Data Interval	Data Report Interval	R	10, 30, 60, 120, 180, 240, 300, 600	60	Seconds
WIO Module	Node Type	Node Function Type Mask	R	Detector /Relay / Router	–	
WIO Module	Power Type	Power Source Type	R	Battery Only(0), Battery Charging(1), Fully charged + AC(2), AC(4)	–	
WIO Module	Device Type	Zigbee Device Type	R	Reduce Function device/Full function device	–	0:Reduce Function device / 1:Full function device
WIO Module	Power Saving	Power saving mode	R	Standard/Router	–	0: Standard, 1:Router
WIO Module	GPS Enable	Where GPS information is provided	R	None/Enable	–	0:None, 1:Enable

Configurable Parameter Reference Guide

Module	Name	Description	Read/Write	Range	Default Value	Remark
System	DHCP Enable	DHCP / manual IP setting	R/W	Enable/Disable	Disable	0
System	Static IP Address	Static IP Address	R/W	Alphanumeric Character Range	192.168.0.100	xxx.xxx.xxx.xxx
System	Static Subnet Address	Static Subnet Address	R/W	Alphanumeric Character Range	255.255.255.0	xxx.xxx.xxx.xxx
System	Static Gateway Address	Static Gateway Address	R/W	Alphanumeric Character Range	192.168.0.1	xxx.xxx.xxx.xxx
System	Operator Password	Password for Access Level Operator	R/W	35 chars	TPPL	0
System	Maintainer Password	Password for Access Level Maintainer	R/W	35 chars	TPPL	0
System	Admin Password	Password for Access Level Admin	R/W	35 chars	TPPL	0
System	Web Operator Password	Reserved	R/W	35 chars	TPPL	0
System	Service Contact	Set service contact on screen	R/W	120 chars	tpp@honeywell.com	0
System	System Label	Set system label on screen	R/W	50 chars	TPPL	0
System	Home Screen	Set Home screen type	R/W	List, tile, sum	List(0)	0
System	Enable Remote Inhibit	Set remote inhibit input	R/W	Enable/Disable	Disable(0)	0
System	Remote Inhibit State	Get remote Inhibit	R/W	Open/Close	Open(0)	Normal Open(0), Normal Close(1)
System	Menu Timeout	Set menu exit timeout	R/W	5~100	90	seconds
System	Auto Logout Timeout	Set menu logout time	R/W	15~100	15	minutes
System	Dedicated Alarm port 1	Set alarm event for dedicated alarm port #1	R/W	Alarm1/Alarm2/Alarm3	0(Alarm1)	0
System	Dedicated Alarm port 2	Set alarm event for dedicated alarm port #2	R/W	Alarm1/Alarm2/Alarm3	1(Alarm2)	0
System	Enable Remote reset/ack	Set enable/disable remote reset/ack	R/W	Enable/Disable	Disable	
System	Gas log Interval	Gas log interval for mA inputs	R/W	0~600	15	0: Disable, second

Configurable Parameter Reference Guide

Module	Name	Description	Read/Write	Range	Default Value	Remark
System	Gas log Threshold	Set Threshold for gas logging for mA inputs	R/W	0.1~2.0	0	%FS 0 means that gas log will be stored every log interval
System	Buzzer Enable	Set buzzer sounder enable/disable for events	R/W	Enable/Disable	Disable	0
System	Buzzer activation on Warning enable	Set buzzer sounder enable/disable for warning	R/W	Enable/Disable	Enable	0
System	LCD Timeout	Set LCD screen saver timeout	R/W	30	30	seconds
System	LCD Brightness	Set LCD brightness	R/W	10~100	100	%
System	Language Setting	Select language for LCD screen	R/W	0~9	english(0)	ENGLISH = 0u, CHINESE, FRENCH, GERMAN, DUTCH, ESPANOL, RUSSIAN, PORTUGUESE
System	Time Format	Set time, date format	R/W	0~3	0	0 HH:MM:SS DD/MM/YYYY 1 HH:MM:SS DD/MM/YY 2 YY/MM/DD HH:MM:SS 3 HH:MM:SS MM/DD/YY
System	Modbus TCP Port	Modbus TCP Port	R/W	0~9999	502	
System	Data Log Interval	Set wireless Datalog Interval (seconds)	R/W	5~600	60	
System	PAN ID	Radio PanID	R/W	0~999	999	
System	Radio Channel Number	Radio Channel	R/W	11~26	15	
System	Online Monitoring	Set a count for minimum online monitoring	R/W	0.1~64	0	0: Disable
System	Echo View	Set enable/disable Echo view can join network	R/W	Enable/Disable	Disable	0
System	Wireless Power	Set wireless power	R/W	High/Medium/Low	High	

Configurable Parameter Reference Guide

Parameter Name	Parameter Description	Applies to	Read/Write	Default Value	Measurement units
Alarm 1 Enable	Alarm enable/disable. 0 = Disabled 1 = Enabled	All	RW	1	n/a
Alarm 1 Function	Type of alarm function. Default is threshold. 0=Threshold, 1=STEL, 2=TWA	All	RW	0	n/a
Alarm 1 Level	Alarm 1 threshold concentration	All	RW	20 %FSD	conc.
Alarm 1 Trigger	Alarm trigger option. 0 = Rising 1 = Falling	All	RW	1 for O ₂ , 0 for other gases	n/a
Alarm 2 Enable	Alarm enable/disable. 0 = Disabled 1 = Enabled	All	RW	1	n/a
Alarm 2 Function	Type of alarm function. Default is threshold. 0=Threshold, 1=STEL, 2=TWA	All	RW	0	n/a
Alarm 2 Level	Alarm 2 threshold concentration	All	RW	40 %FSD	conc.
Alarm 2 Trigger	Alarm trigger option. 0 = Rising 1 = Falling	All	RW	1 for O ₂ , 0 for other gases	n/a
Alarm 3 Enable	Alarm enable/disable. 0 = Disabled 1 = Enabled	All	RW	1	n/a
Alarm 3 Function	Type of alarm function. Default is threshold. 0=Threshold, 1=STEL, 2=TWA	All	RW	0	n/a
Alarm 3 Level	Alarm 3 threshold concentration	All	RW	60 %FSD	conc.
Alarm 3 Trigger	Alarm trigger option. 0 = Rising 1 = Falling	All	RW	0	n/a
Alarm Hysteresis	Alarm hysteresis is to avoid the alarm from frequent on/off when the gas reading is close to the alarm threshold. When clearing the gas alarm, the gas reading should go below gas alarm threshold hysteresis. The hysteresis is defined in % of Full range (Default 2%)	All	RW	2	%FSD
Alarm Latch	Alarm latch option. Alarm will be continued until manual user reset if latching is enabled. 0: Disabled, 1: Enabled	All	RW	1	n/a
Cal Interval	Recommended calibration interval in days. Default is 6 months	All	RW	180	days
Default Range	Full scale range.	All	RW		conc.

Configurable Parameter Reference Guide

Parameter Name	Parameter Description	Applies to	Read/Write	Default Value	Measurement units
Detector Index	Index of detector that is used internally	All	R	per detector	n/a
Detector Name	Detector name.	All	RW	per detector	n/a
Formula Gas Name	Formula for the target measuring gas	All	R	per target gas	n/a
Gas Digit	Index of decimal places for the gas relevant parameters	All	RW	per target gas	n/a
Gas Index	Pre-defined gas index. Internal parameter.	All	R	per target gas	n/a
Gas Name	Target gas name	All	RW	per target gas	n/a
Gas Over Range Limit	Over-range gas concentration limit. This parameter is used to generate over-range warning	All	RW	110 %FSD	conc.
Gas Type	Toxic (0), O2 (1), Flammable (2) Set automatically by Gas Name	All	RW	per target gas	n/a
Gas Under Range Limit	Negative reading limit	All	RW	-7 %FSD	conc.
Gas Unit	Measurement unit Strings: %, ppm, %LEL, %VOL, mA	All	R	per target gas	n/a
Gas Unit Index	Index of measurement unit	All	R	per target gas	n/a
Group	Type of sensor catalogue. mV input = 0, mA input = 1	All	R	per target gas	n/a
Inhibit Timeout	Inhibit timeout in minutes. 0 means permanent inhibit	All	RW	10	minutes
Item Name	Sensor catalogue name. Default name consists of <Detector Name> and <Sensor Name>	All	R	—	n/a
Lower Zero Dead Band	Lower deadband range. The gas concentration within the deadband limit will be suppressed to default base concentration. I.e. if the gas concentration is between the (default base concentration - lower deadband) and (default base concentration + upper deadband), then the reading will be the default base concentration.	All	RW	-2 %FSD	conc.
Max Range	Maximum configurable measuring range Note: wireless detectors are fixed and only trend range can be changed.	All	R		conc.

Configurable Parameter Reference Guide

Parameter Name	Parameter Description	Applies to	Read/Write	Default Value	Measurement units
Min Range	Minimum configurable measuring range Note: wireless detectors are fixed and only trend range can be changed.	All	R		conc.
Resolution	Index of display resolution for gas relevant parameters	All	RW	per target gas	n/a
Sensor Name	Sensor name consists of gas name, full scale range and measurement unit	All	R	per target gas	n/a
Signal Fault Max	Upper mA input signal range to detect the fault reported by the detector	mA sensor only	RW	1.1	mA
Signal Fault Min	Lower mA input signal range to detect the fault reported by the detector	mA sensor only	RW	0	mA
Signal Inhibit Max	Upper mA input signal range to detect whether detector is inhibited or not	mA sensor only	RW	2.2	mA
Signal Inhibit Min	Lower mA input signal range to detect whether detector is inhibited or not	mA sensor only	RW	1.8	mA
Signal Over Range Limit	Upper allowable limit for the input signal from the sensor/detector. If the signal is out of this limit, the I/O board will generate an input signal fault	All	RW	22	mA
Signal Under Range Limit	Lower allowable limit for the input signal from the sensor/detector. If the signal is out of this limit, the I/O board will generate an input signal fault	All	RW	100 %FSD	mA
Signal Warning Max	Upper mA input signal range to detect remote warning from the detector	mA sensor only	RW	0	mA
Signal Warning Min	Lower mA input signal range to detect remote warning from the detector	mA sensor only	RW	0	mA
Span Calibration Conc.	Target span gas concentration. Normally it is 50 %FSD	All	RW	50 %FSD	conc.
STEL Interval	STEL period in minutes. The catalogue is using index instead.	mA sensor only	RW	15	minutes
TWA Interval	TWA period in hours. The catalogue is using index instead.	mA sensor only	RW	8	hours

Configurable Parameter Reference Guide

Parameter Name	Parameter Description	Applies to	Read/Write	Default Value	Measurement units
Upper Zero Dead Band	Upper deadband range. The gas concentration within the deadband limit will be suppressed to default base concentration. In other words if the gas concentration is between (default base concentration - lower deadband) and (default base concentration + upper deadband), then the reading will be default base concentration.	All	RW	2 %FSD	conc.
Zero Range	Zero gas concentration. It is normally zero	All	RW	0	conc.

Event Codes

Chapter 15 Event Codes

Type	Code	Long Description	Triggered	Display in Event History	Details
Alarm	1	Alarm1 occurred	Main Board	Alarm1 occurred CH: xx, Type: xx, xxx[unit]	Alarm types: Threshold, STEL, TWA
Alarm	2	Alarm2 occurred	Main Board	Alarm2 occurred CH: xx, Type: xx, xxx[unit]	Alarm types: Threshold, STEL, TWA
Alarm	3	Alarm3 occurred	Main Board	Alarm3 occurred CH: xx, Type: xx, xxx[unit]	Alarm types: Threshold, STEL, TWA
Alarm	4	Alarm1 self-cleared	Main Board	Alarm1 cleared CH: xx, Type: xx, xxx[unit]	Alarm types: Threshold, STEL, TWA
Alarm	5	Alarm2 self-cleared	Main Board	Alarm2 cleared CH: xx, Type: xx, xxx[unit]	Alarm types: Threshold, STEL, TWA
Alarm	6	Alarm3 self-cleared	Main Board	Alarm3 cleared CH: xx, Type: xx, xxx[unit]	Alarm types: Threshold, STEL, TWA
Alarm	7	Reset all alarms by user	Main Board	Reset all alarms	
Alarm	8	Wireless Alarm 1 occurred	WIO Board	Alarm1 occurred UID : 0xNNNN [xx], Type: xx, xxx[unit]	Node id # Sensor index # Alarm type (0 : Low, 1 : High, 2: OverRange, 3: STEL, 4: TWA, 5: LowLow, 6:HighHigh, 7: Unknown)
Alarm	9	Wireless Alarm 2 occurred	WIO Board	Alarm2 occurred UID : 0xNNNN [xx], Type: xx, xxx[unit]	Node id # Sensor index # Alarm type (0 : Low, 1 : High, 2: OverRange, 3: STEL, 4: TWA, 5: LowLow, 6:HighHigh, 7: Unknown)
Alarm	10	Wireless Alarm 3 occurred	WIO Board	Alarm3 occurred UID : 0xNNNN [xx], Type: xx, xxx[unit]	Node id # Sensor index # Alarm type (0 : Low, 1 : High, 2: OverRange, 3: STEL, 4: TWA, 5: LowLow, 6:HighHigh, 7: Unknown)
Alarm	11	Wireless Alarm 1 cleared	WIO Board	Alarm1 cleared UID : 0xNNNN [xx], Type: xx, xxx[unit]	Node id # Sensor index # Alarm type (0 : Low, 1 : High, 2: OverRange, 3: STEL, 4: TWA, 5: LowLow, 6:HighHigh, 7: Unknown)
Alarm	12	Wireless Alarm 2 cleared	WIO Board	Alarm2 cleared UID : 0xNNNN [xx], Type: xx, xxx[unit]	Node id # Sensor index # Alarm type (0 : Low, 1 : High, 2: OverRange, 3: STEL, 4: TWA, 5: LowLow, 6:HighHigh, 7: Unknown)
Alarm	13	Wireless Alarm 3 cleared	WIO Board	Alarm3 cleared UID : 0xNNNN [xx], Type: xx, xxx[unit]	Node id # Sensor index # Alarm type (0 : Low, 1 : High, 2: OverRange, 3: STEL, 4: TWA, 5: LowLow, 6:HighHigh, 7: Unknown)

Event Codes

Type	Code	Long Description	Triggered	Display in Event History	Details
Alarm	14	MANDOWN alarm occurred	WIO Board	MANDOWN alarm occurred UID : 0xNNNN [xx], Type: xxx	Node id #, MANDOWN Alarm type (0 : Panic , 1 : Man down, 2: Super, 255: Unknown)
Alarm	15	MANDOWN alarm cleared	WIO Board	MANDOWN cleared UID : 0xNNNN [xx], Type: xxx	Node id #, MANDOWN Alarm type (0 : Panic , 1 : Man down, 2: Super, 255: Unknown)
Fault	1	Internal communication fault	All	Communication fault [B/D Type], [Fault Description]	[B/D type] 0:Main, 1:UI, 2:mA Input, 3 : mV input, 4:Relay, 5:mA output, 7:Modbus, 7:Extension power [Fault Description] 0: SPI , 1: I2C , 2: IO CAN , 3: Main CAN, 4: UI CAN, 4: Ext CAN, 6: UART failure, 7; M3 Modem
Fault	2	internal memory fault	IO board / Main board	Memory fault [B/D Type], [Fault Description]	[B/D type] 0:Main, 1:UI, 2:mA Input, 3 : mV input, 4:Relay, 5:mA output, 7:Modbus, 7:Extension power [Fault Description] 0: Internal RAM, 1: External RAM , 2: Code memory, 3: EEPROM, 4: Flash
Fault	3	Catalog memory corrupted	UI	Catalog memory fault	
Fault	4	Internal HW fault	IO board / Main board	Internal hardware fault [B/D Type]	[B/D type] 0:Main, 1:UI, 2:mA Input, 3 : mV input, 4:Relay, 5:mA output
Fault	5	Sensor circuit fault	IO board	Sensor circuit fault CH: xx, Code: xxx	Code 0: Gain setting error, 1: signal conditioning circuit error
Fault	6	Supplied voltage fault	IO board / Main board	Supplied voltage fault [B/D Type], Code: xxx	Code 0: Vapp low, 1: V5 low, 2: V3.3 low, 3: V12 low, 4: V9 low
Fault	7	Internal software failure	IO board / Main board	Internal software fault [B/D Type], Code: xxx	Code 0: BUFFER OVERFLOW, 1: instruction test failed 2: Sequence Checking failed
Fault	8	Modbus communication failure	IO board	Modbus Comm Fault CH: xx, Node: xx	
Fault	9	Sensor fault (including signal range fault)	IO board	Sensor Fault CH: xx, [B/D Type], Code: xx	[B/D type] 0:Main, 1:UI, 2:mA Input, 3 : mV input, 4:Relay, 5:mA output 0 : bead open/short 1 : line open/short 2 : detector short 3 : operating voltage fault 4: driver current fault

Event Codes

Type	Code	Long Description	Triggered	Display in Event History	Details
Fault	10	Analogue output mismatched	IO board	mA Output Error CH: xx	
Fault	11	Relay not controlled	IO board / Main board	Relay Output Error CH: xx	
Fault	12	Remote fault informed by detector (depending on fault signal range)	IO board	Detector In Fault CH: xx, [B/D Type]	[B/D type] 0:Main, 1:UI, 2:mA Input, 3 : mV input, 4:Relay, 5:mA output
Fault	13	Auxiliary battery fault	Main Board	Battery Fault [Enclosure]	[Enclosure] 0: master enclosure,
Fault	14	IO board not matched or present	Main Board	IO B/D Not Matched Slot: xx-x, Prev: xxx, Curr: xxx	Prev, Curr B/D type 0:Main, 1:UI, 2:mA Input, 3 : mV input, 4:Relay, 5:mA output
Fault	15	Cell is producing a negative reading (depending on gas under-range limit)	Main Board	Negative Reading CH: xx, Conc: xxxx [unit]	
Fault	16	Fault self-cleared	Main Board	Fault Cleared CH: xx, Code: xx	Code Code Number (1~22)
Fault	17	Reset all faults by a user	Main Board	Reset all faults	
Fault	18	Wireless node fault	WIO board	Wireless Node Fault UID: xxxx, Code : xxx, Raw : xxx	Code 0 : battery low, Raw (xx%) 1 : pump stall 2 : memory full 3 : Unit failure Raw Fault code '0' : battery level (xx%)
Fault	19	Online detector monitoring fault		Online detector monitoring fault Online : xxx, Total : xxx	
Fault	20	Wireless node battery low	WIO Board	Battery is low UID: xxxx, xxx %	
Fault	21	Wireless Sensor fault	WIO Board	Wireless Sensor in Fault UID: xxxx[xx], Code: xx	Code 0 : General sensor fault 1 : Saturated sensor fault 2 : sensor calibration fail 3 : Lamp fault 4 : Sensor off 5: short circuit 6 : sensor broken 7 : hardware fault
Fault	22	Wireless Sensor Negative Reading	Main Board	Negative Reading UID: xxxx[xx], Conc: xxxx [unit]	
Inhibit	1	Inhibited input channel by LUI	Main Board	Inhibited input channel CH: xx	
Inhibit	2	Cleared inhibit mode for input channel by LUI	Main Board	Cleared inhibit mode CH: xx	
Inhibit	3	Inhibited all input channels remotely	Main Board	Inhibited all channels remotely	

Event Codes

Type	Code	Long Description	Triggered	Display in Event History	Details
Inhibit	4	Cleared inhibit mode for all input channel remotely	Main Board	Cleared inhibit mode remotely CH: xx	
Inhibit	5	Detected inhibit input from detector	IO board	Detector In Inhibit CH: xx	
Warning	1	Battery low (not critical)	Main Board	Battery is low [Enclosure], xxx %	[Enclosure] 0: master enclosure
Warning	2	Battery is not being charged	Main Board	Battery not charged [Enclosure]	[Enclosure] 0: master enclosure
Warning	3	Critical low battery	Main Board	Battery is too low [Enclosure], xxx %	[Enclosure] 0: master enclosure
Warning	4	Over-range warning (depending on gas over-range limit)	Main Board	Over range CH: xx, Conc: xxxx [unit]	
Warning	5	Calibration is due soon	Main Board	Calibration is overdue CH: xx, Due: xxxx	Due Calibration interval - days passed after successful calibration
Warning	6	Time/date not set	UI Board	Date/Time not set [Date/Time]	
Warning	7	IP conflicts detected	UI Board	IP Conflicts xxx.xxx.xxx.xxx	
Warning	8	Remote warning informed by detector	IO board	Detector In warning CH: xx	
Warning	9	Language memory corrupted	UI Board	Language memory fault	
Warning	10	Log memory corrupted	UI Board	Log memory fault	
Warning	11	Warning self-cleared (non-latching)	Main Board	Warning Cleared CH: xx, Code: xx	Code A warning number (1~20)
Warning	12	Reset all warnings by a user	Main Board	Reset all warning	
Warning	13	SD Card Corrupted	UI Board	SD Card fault	
Warning	14	Too many unsuccessful login attempts	UI Board	10 times' login failed	
Warning	15	GPS Failure	WIO Board	GPS Failure UID : xxxx	
Warning	16	Wireless sensor Calibration is due soon	WIO Board	Calibration is overdue UID: xxxx[xx], Due: xxxx	
Warning	17	Wireless sensor Bump is due soon	WIO Board	Bump is overdue UID: xxxx[xx], Due: xxxx	
Warning	18	Wireless sensor Over-range warning	WIO Board	Over range UID: xxxx[xx], Conc: xxxx [unit]	
Warning	19	Wireless sensor Bump fail	WIO Board	Bump fail UID: xxxx[xx], Conc: xxxx [unit]	
Warning	20	Wireless sensor warning	WIO Board	Wireless Sensor warning UID: xxxx[xx], Code: xx	
Info	1	Instrument power on	UI Board	Unit powered on	
Info	2	Switched into power-off mode	UI Board	Ready for power-off [Reason]	
Info	3	Instrument rebooted automatically	UI Board	Unit rebooted [Reason]	

Event Codes

Type	Code	Long Description	Triggered	Display in Event History	Details
Info	4	Instrument power changed from AC to DC	Main Board	Switched to Battery [Enclosure]	[Enclosure] 0: master enclosure
Info	5	Instrument power changed from DC to AC	Main Board	Switched to AC [Enclosure]	[Enclosure] 0: master enclosure
Info	6	Added IO board	UI Board	Added IO board [B/D Type], Slot: xx-x	[B/D type] 0:Main, 1:UI, 2:mA Input, 3: mV input, 4:Relay, 5:mA output
Info	7	Removed IO board	UI Board	Remove IO board [B/D Type], Slot:xx-x	[B/D type] 0:Main, 1:UI, 2:mA Input, 3: mV input, 4:Relay, 5:mA output
Info	8	Replaced IO board	UI Board	Replaced IO board [B/D Type], Slot: xx-x	[B/D type] 0:Main, 1:UI, 2:mA Input, 3: mV input, 4:Relay, 5:mA output
Info	9	Enabled IO channel	UI Board	Enabled channel CH: xx, [B/D Type]	[B/D type] 0:Main, 1:UI, 2:mA Input, 3: mV input, 4:Relay, 5:mA output
Info	10	Disabled IO channel	UI Board	Disabled channel CH: xx, [B/D Type]	[B/D type] 0:Main, 1:UI, 2:mA Input, 3: mV input, 4:Relay, 5:mA output
Info	11	Local Login	UI Board	Logged in unit [operator]	[operator] 0: Operator, 1: Maintainer, 2: Administrator
Info	12	Local Logout	UI Board	Logged out from unit [Role]	[Role] 0: Normal, 1:Time-out
Info	13	Local login failed	UI Board	Login failed [operator]	[operator] 0: Operator, 1: Maintainer, 2: Administrator
Info	14	Reserved			
Info	15	Reserved			
Info	16	Reserved			
Info	17	Calibration successful	Main Board	Calibration passed CH: xx, Type: xx, Conc: xxx[unit]	
Info	18	Calibration failed	Main Board	Calibration failed CH: xx, Type: xx, Conc: xxx[unit]	
Info	19	mA Input Configuration Changed	Main Board	Configured mA input channel CH: xx	
Info	20	Reserved			
Info	21	Reserved			
Info	22	Relay Output Configuration Changed	Main Board	Configured relay output channel CH: xx	
Info	23	Reserved			
Info	24	Button Press – Acknowledge alarms and faults	Main Board	Pressed Ack button [button type]	[Button type] 0:On Board, 1:Remote

Event Codes

Type	Code	Long Description	Triggered	Display in Event History	Details
Info	25	Button Press – Reset alarms and faults	Main Board	Pressed Reset button [button type]	[Button type] 0:On Board, 1:Remote, 2: LUI
Info	26	Reset peak readings	UI Board	Reset Peak Reading CH: xxx (individual or All)	
Info	27	Exported system configuration	UI Board	Exported system Configuration	
Info	28	Imported system configuration	UI Board	Imported system Configuration	
Info	29	Changed system date/time settings via LUI	UI Board	Changed date/time YYYY:MM:DD hh:mm:ss	
Info	30	Changed system language	UI Board	Changed language [Language ID]	[Language ID] 0: English, 1: China, 2:French, 3:German, 4:Netherlands, 5:Spain, 6:Russian, 7:Portugal
Info	31	Changed network settings	UI Board	Changed network settings [Network Type]	[Network Type] 0: Ethernet, 1: RS485, 2: Mesh Network, 3. Modbus port
Info	32	Reserved			
Info	33	Touch screen calibration successful	UI Board	Passed touch calibration	-
Info	34	Touch screen calibration failed	UI Board	Failed in touch calibration	-
Info	35	Changed LCD backlight settings	UI Board	Changed LCD settings	-
Info	36	SD Card was inserted	UI Board	SD Card inserted	
	37	SD card was removed	UI Board	SD Card removed	Removal Type 0: gracefully, 1: abruptly
Info	38	Formatted SD card successfully	UI Board	SD Card formatted	
Info	39	SD card is not formatted / corrupted	UI Board	SD Card not formatted	
Info	40	SD card is almost full	UI Board	SD Card almost full	
Info	41	Changed password settings	UI Board	Changed password [operator]	
Info	42	Changed system Label	UI Board	Changed system label	
Info	43	mA Input calibration successful	UI Board	mA Input calibration passed Ch: xxx	
Info	44	mA Input calibration failed	UI Board	mA Input calibration failed CH: xx	
Info	45	mA Output calibration successful	UI Board	mA output calibration passed CH: xx	
Info	46	mA Output calibration failed	UI Board	mA output calibration failed CH: xx	
Info	47	Reserved	-	-	
Info	48	Reserved	-	-	
Info	49	Reserved	-	-	

Event Codes

Type	Code	Long Description	Triggered	Display in Event History	Details
Info	50	Reserved	-	-	
Info	51	Reserved	-	-	
Info	52	Reserved	-	-	
Info	53	Reserved	-	-	
Info	54	Relay output forced	UI Board	Forced relay CH: xx	
Info	55	Relay output released	UI Board	Released Relay CH: xx	
Info	56	Analogue output forced	UI Board	Forced mA output CH: xx, xxx mA	
Info	57	Analogue output released	UI Board	Release mA output CH: xx	
Info	58	Started input channel test	UI Board	Started channel test	
Info	59	Ended input channel test	UI Board	Ended channel test	
Info	60	Started Relay Output Simulation	UI Board	Started Relay Sim. CH: xx	
Info	61	Ended Relay Output Simulation	UI Board	Ended Relay Sim. CH: xx	
Info	62	Updated Firmware	UI Board	FW Updated [B/D Type], Ver: x.x.x	[B/D type] 0:Main, 1:UI, 2:mA Input, 3 : mV input, 4:Relay, 5:mA output, 7:Modbus, 7:Extension power
Info	63	Firmware Update failed	UI Board	FW Update Failed [B/D Type], Ver: x.x.x	[B/D type] 0:Main, 1:UI, 2:mA Input, 3 : mV input, 4:Relay, 5:mA output
Info	64	Updated sensor catalogue	UI board	Catalog Updated Ver: xxxx	
Info	65	Failed in Catalog update	UI Board	Catalog Update failed Ver: xxxx	
Info	66	Reserved			
Info	67	Reserved			
Info	68	Updated language	UI Board	Font Updated Ver: xxxx	
Info	69	Failed in language update	UI Board	Font Update Failed Ver: xxxx	
Info	70	Removed IO channel	UI Board	Removed channel CH: xx, [B/D Type]	[B/D type] 0:Main, 1:UI, 2:mA Input, 3 : mV input, 4:Relay, 5:mA output
Info	71	Updated module data	UI Board	Updated module data [B/D type], Ver: xxxx	[B/D type] 0:Main, 1:UI, 2:mA Input, 3 : mV input, 4:Relay, 5:mA output
Info	72	Failed in module data update	UI Board	Failed in module data update [B/D type], Ver: xxxx	[B/D type] 0:Main, 1:UI, 2:mA Input, 3 : mV input, 4:Relay, 5:mA output

Event Codes

Type	Code	Long Description	Triggered	Display in Event History	Details
Info	73	Connected wireless Node (Detector / Relay / Router)	Main board	Added New wireless Node UID : xxx, [instrument Name]	Wireless Node's Online State
Info	74	Online Wireless Node	Main board	Online wireless Node UID : xxx, [instrument Name]	Offline -> Online
Info	75	Offline Wireless Node	Main board	Offline wireless Node UID : xxx, [instrument Name]	Wireless Node's Offline State
Info	76	Removed Wireless Node	Main board	Removed wireless Node UID : xxx, [instrument Name]	
Info	77	Enable WindSensor	Main board	Wind Sensor Enabled Ch: XX	
Info	78	Disable WindSensor	Main board	Wind Sensor Disabled Ch: XX	
Info	79	Changed Configuration wireless Node (Detector / Relay / Router)	Main board	Changed config of wireless Node UID : xxx, [instrument Name]	
Info	80	Reserved	-	-	-
Info	81	Changed Pre-Shared Secure Key	Main board	Changed PSK	
Info	82	Receive Mesh Network Ping	Wireless IO board	Received MeshNet Ping UID : xxx, [instrument Name]	
Info	83	Mesh Network Full	Wireless IO board	MeshNet Buffer Full UID : xxx, [instrument Name]	
Info	84	Mesh Network Refresh	UI Board	Refresh Type: 0 : Offline Only, 1 : All nodes	
Info	85	Reset module	Main Board	Board type, Board position Board Type => 0:Main, 1:UI, 2:mA Input, 4:Relay, 5:mA output, 7:Modbus, 7:Extension power	
Info	86	Wireless Digital Input	Main Board	Unique ID #, code # (0 : Off, 1 : On)	

List Of Figures

Chapter 16 – List of Figures

Figure 1.	Quickstart Guide Label (Not to Scale)	7
Figure 2.	SMPS Voltage Warning Label (Removed During Installation)	7
Figure 3.	Protective Earth (Ground) Point	7
Figure 4.	Equipment Earth (Ground) Point	7
Figure 5.	Internal Label Positions	7
Figure 6.	Touchpoint Plus Wireless Wall-Mounted Controller	12
Figure 7.	Typical Installation Options	13
Figure 8.	Controller Exploded View	13
Figure 9.	System Layout Before Installation	17
Figure 10.	Undoing the Security Screws and Opening the Enclosure	19
Figure 11.	Installation Clearance Measurements	20
Figure 12.	Wall Mounting Points	20
Figure 13.	Wall Mounting Plate Option	20
Figure 14.	Fixing Orientation When Using the Optional Mounting Plate	22
Figure 15.	Switched Mode Power Supply (SMPS) Connections	24
Figure 16.	Connections for DC 24 V Supply	25
Figure 17.	Dedicated Alarm Circuit Connections	28
Figure 18.	Optional Remote Reset and Inhibit Switch Connections.	28
Figure 19.	Three Wire Device Powered by a mA Input Module	29
Figure 20.	Three Wire Device Powered by an External Source	30
Figure 21.	Two Wire Device Powered by a mA Input Module	30
Figure 22.	Two Wire Device Powered by an External Source	30
Figure 23.	Two Wire Device Barrier Device Powered by a mA Input Module	31
Figure 24.	Grounding for Screened Cable with Armour and with Metal Junction Box and Sensor	31
Figure 25.	Grounding for Screened Cable, No Armour, with Metal Junction Box and Sensor	31
Figure 26.	Grounding for Screened and Armoured Cable with Plastic Junction Box and Sensor	32
Figure 27.	Grounding for Screened Cable with Plastic Junction Box and Sensor	32
Figure 28.	Grounding for Antenna	32
Figure 29.	Grounding for Antenna Extension	33
Figure 30.	FA324 Connection	35
Figure 31.	FA324 Connector Cable 1 Wiring	36
Figure 32.	FA324 Connector Cable 2 Wiring	36
Figure 33.	RAEMet Wind Sensor Connection	38
Figure 34.	Relay States	40
Figure 35.	Touchpoint Plus Wireless Controller User Interface	41
Figure 36.	SD Card Location	84
Figure 37.	Battery On/Off Switch and Battery Connector	86

List of Tables

Chapter 17 – List of Tables

Table 1.	System Power Calculations	14
Table 2.	Power Supply (SMPS RS–150–24) Electrical Ratings	15
Table 3.	System Weights	15
Table 4.	System Dimensions	15
Table 5.	Regional Power Cable Colours	24
Table 6.	Main Module Connections	27
Table 7.	mA Input Module Connections	29
Table 8.	Relay Output Module Connections	39
Table 9.	User / Component Matrix	44

Find out more at
www.honeywellanalytics.com

Contact Honeywell Analytics:

Europe, Middle East, Africa, India

Life Safety Distribution GmbH
Javastrasse 28604
Hegnau
Switzerland
Tel: +41 (0)44 943 4300
Fax: +41 (0)44 943 4398
gasdetection@honeywell.com

Customer Service:

Tel: 00800 333 222 44 (Freephone number)
Tel: +41 44 943 4380 (Alternative number)
Fax: 00800 333 222 55
Middle East Tel: +971 4 450 5800 (Fixed Gas Detection)
Middle East Tel: +971 4 450 5852 (Portable Gas Detection)
India Tel: +91 124 4752700

Americas

Honeywell Analytics Inc.
405 Barclay Blvd.
Lincolnshire,
IL 60069
USA
Tel: +1 847 955 8200
Toll free: +1 800 538 0363
Fax: +1 847 955 8210
detectgas@honeywell.com
www.honeywell.com

Asia Pacific

Honeywell Analytics Asia Pacific
#701 Kolon Science Valley (1)
43 Digital-Ro 34-Gil, Guro-Gu
Seoul 152-729
Korea
Tel: +82 (0)2 6909 0300
Fax: +82 (0)2 2025 0328
analytics.ap@honeywell.com

Technical Services

EMEA: HAexpert@honeywell.com
US: ha.us.service@honeywell.com
AP: ha.ap.service@honeywell.com

www.honeywell.com

Please Note:
While every effort has been made to ensure accuracy in this publication, no responsibility can be accepted for errors or omissions. Data may change, as well as legislation and you are strongly advised to obtain copies of the most recently issued regulations, standards and guidelines. This publication is not intended to form the basis of a contract.

Honeywell

Issue 2_09/2019
H_MAN0984_EMEA
3020M5001 HAA190054
© 2019 Honeywell Analytics



DETECTION | **S**AFETY | **P**ROTECTION

For Pricing or Further
Information Please Contact Us.



+441158390495



www.manonglobal.com



sales@manonglobal.com

**Leading UK Suppliers In
Gas Detection, Safety & Protection
Products
Brand New & Genuine OEM Parts
UK & Worldwide Deliveries Available**



Worldwide Delivery



1000+ Genuine Parts & Equipment