



Touchpoint Pro

REVISION HISTORY

Revision	Comment	Date
Issue 1	A04483	Jan 2015
Issue 2	A04522	Mar 2015
Issue 3	A04548	July 2015
Issue 4	A04815	Nov 2016
Issue 5	A05034	Oct 2017
Issue 6	A05082	Mar 2018

LEGAL NOTICES

Disclaimer

In no event shall Honeywell be liable for any damages or injury of any nature or kind, no matter how caused, that arise from the use of the equipment referred to in this manual.

Strict compliance with the safety procedures set out and referred to in this manual, and extreme care in the use of the equipment, are essential to avoid or minimise the chance of personal injury or damage to the equipment.

The information, figures, illustrations, tables, specifications, and schematics contained in this manual are believed to be correct and accurate as at the date of publication or revision. However, no representation or warranty with respect to such correctness or accuracy is given or implied and Honeywell will not, under any circumstances, be liable to any person or corporation for any loss or damages incurred in connection with the use of this manual.

The information, figures, illustrations, tables, specifications, and schematics contained in this manual are subject to change without notice.

Unauthorised modifications to the gas detection system or its installation are not permitted, as these may give rise to unacceptable health and safety hazards.

By installing this equipment on a computer network, the owner accepts full and unequivocal responsibility for ensuring that it is protected against all cyber threats and illegal tampering during the lifetime of the equipment.

Any software forming part of this equipment should be used only for the purposes for which Honeywell supplied it. The user shall undertake no changes, modifications, conversions, translations into another computer language, or copies (except for a necessary backup copy).

In no event shall Honeywell be liable for any equipment malfunction or damages whatsoever, including (without limitation) incidental, direct, indirect, special, and consequential damages, damages for loss of business profits, business interruption, loss of business information, or other pecuniary loss, resulting from any violation of the above prohibitions.

Warranty

Honeywell Analytics warrants the Touchpoint Pro system against defective parts and workmanship, and will repair or (at its discretion) replace any components that are or may become defective under proper usage within 12 months from the date of commissioning by a Honeywell Analytics approved representative* or 18 months from shipment from Honeywell Analytics, whichever is sooner.

This warranty does not cover consumables, batteries, fuses, normal wear and tear, or damage caused by accident, abuse, improper installation, unauthorized use, modification or repair, ambient environment, poisons, contaminants or abnormal operating conditions.

This warranty does not apply to sensors or components that are covered under separate warranties, or to any 3rd-party cables and components.

Any claim under the Honeywell Analytics Product Warranty must be made within the warranty period and as soon as reasonably practicable after a defect is discovered. Please contact your local Honeywell Analytics Service representative to register your claim.

This is a summary. For full warranty terms please refer to the Honeywell Analytics' General Statement of Limited Product Warranty, which is available on request.

* A Honeywell Analytics approved representative is a qualified person trained or employed by Honeywell Analytics, or a qualified person trained in accordance with this manual.

Copyright Notice

Microsoft, MS and Windows are registered trademarks of Microsoft Corp.

Other brand and product names mentioned in this manual may be trademarks or registered trademarks of their respective companies and are the sole property of their respective holders.

Touchpoint is a registered trademark of Honeywell Analytics (HA).

Find out more at www.honeywellanalytics.com

CONTENTS

Contents

1	Important Safety Information	1
1.1	International Standards	1
1.2	Warnings.....	2
1.3	Cautions.....	3
2	Safety Hazards, Warnings and Cautions.....	5
2.1	Safety.....	5
2.2	Location and Description of Warning Labels.....	8
3	Touchpoint Pro Introduction	11
3.1	TPPR Access Levels	11
3.2	TPPR Control System Layout	12
3.3	TPPR System Key Components	14
3.4	Power Supply Options	20
4	TPPR Mechanical Installation	25
4.1	TPPR Siting Considerations	25
4.2	Installing Wall Mounted Enclosures	26
4.3	Installing Floor Standing Enclosures	28
4.4	Installing the TPPR 19" Rack Mounted Unit.....	29
4.5	Installing the TPPR Panel Mount Controller.....	30
4.6	Installing the Battery Enclosure.....	31
5	TPPR Electrical Installation.....	33
5.1	Power Requirements	33
5.2	Cabling Requirements	34
5.3	Controller Electrical Connections	45
5.4	First Time Switch On.....	49
6	Modbus Installation (Option).....	50
6.1	Introduction	50
6.2	Programming the Host	50
6.3	Addressing Conventions and Register Values	50
6.4	Modbus Bus Interface Board (BIB) Installation	51
6.5	Modbus Cables	53
6.6	Modbus Electrical Connections.....	53
6.7	Modbus RTU Connections.....	53
6.8	Modbus Termination Resistor	53
6.9	Modbus Configuration Examples	54
6.10	Modbus Jumper Settings and Termination Resistor Fitting.....	55
6.11	Modbus Multi-Drop Mode.....	55
7	Software Setup and Commissioning.....	56
7.1	How to Setup or Change the Touchscreen Panel Configuration:.....	56
7.2	How to Calibrate the Touchscreen.....	56
7.3	How to Edit Service Contact Settings	57

CONTENTS

7.4	Configuring the Touchpoint Pro TCP/IP Address and Printer	57
7.5	Enabling TPPR's Remote Connection Port.....	58
7.6	How to Print Active Events.....	58
8	Calibrating Gas Sensors.....	59
8.2	Calibrating AIM-mV Input Channels.....	60
8.3	Calibrating AIM-mA Input Channel Loops.....	62
9	Configuring System Parameters.....	65
9.1	General Considerations	65
9.2	Analogue Input Module 4-20 mA Parameters	66
9.3	Analogue Input Module mV Bridge Parameters.....	75
9.4	Digital Input Module Parameters.....	82
9.5	Relay Output Module Parameters.....	84
9.6	Cause & Effect Matrix	85
9.7	Control of Output Channels – Priority	91
9.8	Power Supply Unit Parameters.....	91
10	Configuring STEL and LTEL Alarms	92
10.1	STEL Operation	92
10.2	LTEL Operation.....	93
11	Configuring Modbus	96
11.1	Modbus Register Allocation for Function 02 – Read Input Status.....	96
11.2	Modbus Register Allocation for Function 04 – Read Input Registers.....	97
11.3	Register Allocation for Function 03 / 06 / 16 – Read / Write Holding Registers	98
11.4	Command Types.....	100
11.5	Exception Responses	101
12	Configuration Files.....	102
12.1	Viewing and Editing the Configuration	102
12.2	To Back Up the Configuration.....	103
12.3	Restoring the Configuration	103
12.4	Deleting the Configuration	104
12.5	CCB Configuration Settings	105
13	Normal Day-to-Day Operation	107
13.1	TPPR Controller Touchscreen Interface	107
13.2	TPPR PC Configuration Software Interface.....	107
13.3	TPPR Webserver Interface	107
13.4	TPPR Safety Function	108
13.5	Touchscreen Operation	108
13.6	How to Recalibrate the Touchscreen.....	112
13.7	Touchscreen Calibration	112
13.8	How to View Input Channels and Input Details.....	112
13.9	How to View Output Channels.....	113
13.10	How to View the Trend Graph.....	114
13.11	How to View Event History.....	115

CONTENTS

13.12	How to View Event Reports	115
13.13	How to Access Diagnostic information.....	115
13.14	Managing the Integral SD Card.....	116
13.15	Accessing Help	117
13.16	System State Relays.....	117
14	Alarms, Faults, Warnings and Inhibits	118
14.1	Latching Alarms	118
14.2	STEL / LTEL Alarms	118
14.3	Rate Alarm.....	119
14.4	Relay Activated Outputs	119
14.5	Sensor Over Range Operation.....	120
14.6	Catalytic Sensor Over Range Operation	120
14.7	Full Scale Exceeded and Over Range Warning Operation	120
14.8	Special Considerations when using Catalytic Sensors	122
14.9	Responding to Alarms, Faults and Warnings.....	124
14.10	Viewing Faults and Warnings.....	126
14.11	Inhibiting a Channel	127
15	Maintenance Procedures.....	129
15.1	Routine Maintenance	129
15.2	Periodic Maintenance	130
16	How to Test the TPPR System	131
16.1	Introduction	131
16.2	LED Panel Test.....	132
16.3	Field Inputs Test	132
16.4	Configuration Settings Test.....	133
16.5	Cause and Effect Test	134
16.6	Panel Button Test	135
16.7	System Relay Test.....	135
16.8	LCD Screen Test	136
16.9	How to Exercise the Output Relays	136
16.10	How to Remove or Replace Modules.....	137
16.11	How to Add or Install a New I/O Module	140
16.12	How to Check the DC-UPS.....	141
16.13	How to Change the Battery Protection Fuse	142
16.14	How to Replace Batteries	142
17	System Troubleshooting	143
17.1	Observed Problem	143
17.2	Other Issues.....	146
18	Error Codes	147
19	Ring Communication Errors	158
19.1	Module Faults	158
19.2	Troubleshooting Module Faults First Response.....	158

CONTENTS

19.3	Troubleshooting Module Faults Second Response.....	159
19.4	Ring Fault Diagnostics and Debugging Techniques	160
20	Further Assistance and Training	163
21	TPPR Specifications	164
21.1	Rack Mounted Equipment.....	164
21.2	Wall Mounted Enclosures	166
21.3	Floor Standing Enclosures.....	168
21.4	Power Supplies and Fuses	169
21.5	Control Module and User Interface	173
21.6	I/O Modules.....	174
22	Certification	177
22.1	EU Declaration of Conformity.....	177
22.2	Applicable National and International Standards	177
22.3	National and International Certificates for Zone 2 Div. 2.....	178
22.4	European Performance Approval (DEKRA Exam) for Systems	178
23	Ordering Information	182
23.1	TPPR System ID Configuration.....	182
23.2	TPPR Components Part Numbers.....	183
24	Disposal of Redundant / Unserviceable Parts	184
24.1	Restriction of Hazardous Substances (RoHS) Directive	184
24.2	Waste Electrical and Electronic Equipment (WEEE) Directive.....	184
24.3	TPPR System Construction	184
25	Table of Icons	186
26	List of Illustrations	188
27	List of Tables	191

SAFETY

1 Important Safety Information

The Equipment referred to in this manual contains components and assemblies that are each certified for use in a variety of differing environments, and it is the site owner's responsibility to confirm the suitability of the equipment and any associated computer networks prior to its installation and use.

The Equipment assemblies referred to in this manual are collectively certified for use in a gas detection system only. Any other use is not currently certified and is not authorised by the manufacturer.

For installation in Canada and the USA, for both ordinary and hazardous locations, all connections, cabling, overcurrent protection and installations must strictly adhere to both the National Electrical Code (NEC) and the Canadian Electrical Code (CEC).

Check the product rating plate and look for the following marks to ensure that the supplied equipment is suitable for its intended location and purpose:

 Products bearing the CE mark conform to all applicable European Directives as stated on the Honeywell product specific EU Declaration of Conformity.

 Products bearing the CSA mark conform to the requirements for Ordinary Locations, and where marked on components and apparatus, Zone 2 and Division 2 Hazardous Locations.

 Products, components and apparatus bearing the ATEX Explosion Protection mark conform to the requirements for Zone 2 Potentially Explosive Atmospheres.



WARNING

FOR SAFETY REASONS THIS EQUIPMENT MUST BE OPERATED BY QUALIFIED PERSONNEL ONLY. READ AND UNDERSTAND THE INSTRUCTION MANUAL COMPLETELY BEFORE OPERATING OR SERVICING THE EQUIPMENT.



ATTENTION

POUR DES RAISONS DE SÉCURITÉ, CET ÉQUIPEMENT DOIT ÊTRE UTILISÉ, ENTRETENU ET RÉPARÉ UNIQUEMENT PAR UN PERSONNEL QUALIFIÉ. ÉTUDIER LE MANUEL D'INSTRUCTIONS EN ENTIER AVANT D'UTILISER, D'ENTREtenir OU DE RÉPARER L'ÉQUIPEMENT.

1.1 International Standards

All personnel should acquaint themselves with the contents of the following standards before commencing work on gas detection systems:

IEC 60079-29-2, which gives guidance on, and recommended practice for, the selection, installation, safe use and maintenance of electrically operated group II apparatus intended for use in industrial and commercial safety applications for the detection and measurement of flammable gases complying with the requirements of EN 60079-29-1.

IEC 60079-20-1, which gives guidance on material characteristics for gas and vapour classification; test methods and data. It also explains how to convert test and calibration gas (span gas) concentrations from %LFL to %v/v.

EN 45544-4, which gives guidance on electrical apparatus used for the direct detection and direct concentration measurement of toxic gases and vapours and a guide for their selection, installation, use and maintenance.

SAFETY

1.2 Warnings

Read the following Warnings and Cautions before starting any work on the TPPER system.



WARNINGS

1. For safety reasons this equipment must be operated by qualified personnel only. Read and understand the Instruction Manual completely before operating or servicing the equipment.
2. The equipment specified in this manual is only to be installed by the Manufacturer's trained personnel, or by competent persons trained in accordance with the Manufacturer's installation instructions.
3. Installation must be in accordance with the recognized standards of the appropriate authority in the country concerned. Refer to local, national and company regulations.
4. To protect against cyber threats, installation on a computer network must be carried out in collaboration with your Company's IT department or professional IT consultants, and the guidelines and recommendations in the *Honeywell Network Security Guide* should be followed.
5. Do not operate the Touchpoint Pro system or its components outside of their rated operating specification.
6. Touchpoint Pro must not be operated in Oxygen enriched atmospheres, i.e. greater than 25% v/v Oxygen.
7. All equipment containing a User Interface must be suitably protected from direct sunlight and rain.
8. Power Supply Fluctuations are not to exceed DC 18 – 32 V SELV Supply or $\pm 10\%$ of nominal.
9. All versions of Enclosure are electrical Class 1, and must be connected to Protective Earth (Ground).
10. The Touchpoint Pro installation must include a means of isolating or disconnecting the input voltage supply. The isolation or disconnection device must be conveniently located close to the system and be clearly labelled. For an AC mains voltage supply, the isolation or disconnection device must disconnect both the line and neutral poles, but maintain earth (ground) continuity.
11. The Touchpoint Pro input voltage supply must include over-current protection.
12. All cabling must be appropriately rated and approved in accordance with local, national and company regulations, and suitable for the installation. Additionally, cabling must satisfy requirements defined in the manuals of connected field devices, in particular if the field device is certified for use in a hazardous location.
13. All signal cables and interconnections must be shielded and the shields terminated only at the unified earth (ground) bus bar situated inside the enclosure.
14. All conduits and cable armour shall be bonded to protective earth (ground). To avoid ground loops, isolating cable entry glands shall be used at the enclosure end where conduits or armour are earthed at the sensor end.
15. Cable entry glands, blanking plugs, reducers, adaptors and breather devices must be suitably approved and must not reduce the IP rating or protection levels. Items should not be used if there is a high risk of mechanical damage to the equipment or enclosure.
16. Cable gland plates or blanking plates must be installed using the supplied gaskets and metal fixings. Failing to do so will invalidate the IP rating.
17. Access doors and entry points must not be opened when a flammable gas atmosphere is present (Class 1 Div.2, Class 1 Zone 2, and Zone 2 [ATEX]).
18. Access doors and entry points must be kept closed when the system is energised in normal operation.
19. All equipment in this manual is rated to +2000 m (6562 ft.) altitude maximum.
20. Touchpoint Pro systems may contain hazardous live terminals. Appropriate precautions should be taken during operation, installation, and maintenance and servicing. Specifically, operators must have appropriate training and experience to be aware of the hazards to which they may be exposed, and of measures to minimise risk to themselves or other people.
21. The protection provided by the equipment may be impaired if the equipment is used in a manner not specified or authorised by the manufacturer. This includes being connected to an insecure TCP/IP network.
22. Be aware that extended exposure of a sensor element to certain concentrations of combustible or toxic gases in air can introduce stress to the element that may seriously affect its performance, and therefore recalibration should be carried out or the sensor replaced, or both, after an alarm due to an indication of a high concentration.
23. Risk Assessments should be carried out and alternative safety arrangements should be put in place BEFORE beginning any servicing or maintenance.

SAFETY

1.3 Cautions



CAUTIONS

1. The USB Device port is for Maintenance use only. End users shall use only the USB Host port with a USB Flash drive, and backup / restore / upgrades shall only be performed with the system in a safe (i.e. inhibited) mode.
2. Touchpoint Pro power supply units, Ring Coupling Modules and Input / Output Modules have no user serviceable parts. In the unlikely event of a failure, the power supply unit or module must be replaced using only manufacturer supplied parts.
3. Do not use sharp objects to operate the Touchscreen as this could irreparably damage the User Interface and adversely affect its IP rating.
4. Use only soft, damp cloths or screen wipes to clean the Touchpoint Pro. Do not use solvents or abrasives as they will damage the User Interface.
5. Once commissioned, Touchpoint Pro is intended for continuous operation.

1.3.1 Intended Readers

This Manual should be read by everyone who installs, commissions, operates or monitors the TPPR gas detection system. In addition this manual may be used to train people who operate or monitor the TPPR gas detection system.

Only personnel who have been fully trained by Honeywell are authorised to Install, Set-up, Commission, Service, Test, Repair, or Recondition Honeywell gas detection systems.



IMPORTANT

Personnel, who work on, or in the area of, the Touchpoint Pro Gas detection system must be made aware of *Chapter 2 – Safety Hazards, Warnings and Cautions*.

Before unpacking the system, please read the documentation that accompanies it.

1.3.2 Conventions Used

The following conventions are used in this manual:

- **'TPPR'** refers to the Touchpoint Pro Gas Detection System.
- **'Start up'** refers to the action of switching on the system ready for use.
- **'Power Cycle'** refers to cycling the power off and then on again.
- **'Boot up'** refers to the action of starting the software from cold.
- **'Reboot'** refers to shutting down and restarting the software without interrupting the power supply.

SAFETY

1.3.3 TPPR Documentation Suite

TPPR documentation is supplied on CD-ROM with new systems, and is available to download from Honeywell Analytics, whose web address is on the back cover.

The downloadable TPPR documentation suite consists of:

User documents:

- Touchpoint Pro Operating Manual
- PC Configuration Software Operating Guide
- Webserver Software Operating Guide

Technical documents:

- Touchpoint Pro Technical Handbook (this document)
- Touchpoint Pro Safety Manual
- Touchpoint Pro Security Guide

1.3.4 Document Translations

TPPR Technical documents are available in English only. The Touchpoint Pro Operating Manual is available in:

- Dutch (NL)
- English (EN)
- French (FR)
- German (DE)
- Italian (IT)
- Russian (RU)
- Spanish (ES)

1.3.5 Associated Documents

TPPR documents should be read in conjunction with 3rd-Party or ancillary component and sensor documentation.

1.3.6 How to Use this Document

This document is not designed to be read 'end-to-end'. Rather it is intended to be used as an authoritative reference work and source of safety information and operational procedures. As such it is organised into logical sections and chapters that allow all levels of reader to quickly access the required information.

This document is organised so that individual sections, chapters or pages can be copied or printed as a quick reference source. All new chapters start on an odd facing page to allow them to 'stand-alone' when printed, and some end pages are deliberately blank for the same reason.

It is strongly recommended that the hyperlinked Contents, Figures, and Table lists, and the PDF bookmark tool, are used for easy navigation.

1.3.7 Further Information and Help

Contact Honeywell Analytics Technical Support for advice if you notice any conflicts between this and other documents.

Contact Honeywell Analytics Sales Support for a list of TPPR-compatible sensors, filters, test gases or other components.

The Honeywell contact details are on the back page of this document.

SAFETY

2 Safety Hazards, Warnings and Cautions

2.1 Safety

Incorrect set-up, maintenance, operation or modification of the Touchpoint Pro gas detection system *or its installation* may constitute a serious hazard to the health and safety of personnel and their environment. It is therefore imperative that the contents of this chapter are thoroughly understood by everyone who has access to the gas detection system or its associated equipment.

When properly installed, fully-enclosed gas detection systems are rated IP65.

Standard systems may be installed in a Pollution Degree 2 (i.e. laboratory, office or control room) or Pollution Degree 3 (i.e. unheated boiler room) environment as defined by IEC/UL/EN 61010–1: Safety requirements for electrical equipment for measurement, control and laboratory use.

In all cases, several hazards may be present when operating or servicing the equipment and extreme caution must be exercised at all times. The hazards that may be encountered include:

- Class 1 electrical hazards (AC 110/220 V, DC 18–32 V)
- Mechanical hazards (Heavy components, swinging access doors)
- Environmental hazards (toxic atmospheres)
- Fire and Ignition hazards (Touchpoint Pro is **not** ATEX/IECEx Zone 1 certified, and cannot be used in flammable atmospheres, or where oxygen concentrations >25% v/v O₂)

2.1.1 Warnings and Cautions

Safety of this equipment is reinforced by the use of safety labels that are fixed to the equipment in a visible manner. The type of safety labels used and their location is detailed in this chapter. In addition, specific hazards are detailed throughout this manual.

The degree of seriousness of a hazard is indicated in this manual by the use of the following signal words (in red) accompanied by a suitable hazard symbol:

DANGER

Indicates an imminent hazard that, if not avoided, is **extremely likely to result** in death or serious injury.

WARNING

Indicates a potentially hazardous situation that, if not avoided, **could result** in death or serious injury.

CAUTION

Indicates a potentially hazardous situation that, if not avoided, **may result** in minor or moderate injury. It is also used to alert the user against unsafe working practices and potential damage to equipment.

SAFETY

2.1.2 Safety Hazards

The following specific hazards are associated with the use of this equipment:



DANGER – IGNITION HAZARD

The Touchpoint Pro Controller is NOT ATEX/IECEx safe, and it may only be installed in safe areas where there are no flammable atmospheres, and no oxygen concentrations >25 % v/v O₂.



DANGER – IGNITION HAZARD

The Touchpoint Pro range includes a wall mounted enclosure that is certified as ATEX/IECEx Zone 2, Class I Div. 2 and Class I (Zone 2) safe, but this enclosure can only be installed as a remote unit.

ATEX certified components may be used within the Touchpoint Pro and these bear the ATEX imprint shown to the left.



WARNING – LETHAL VOLTAGE PRESENT

All power supplies must be hard wired and must include a circuit breaker (RCD / RCCB), and (close by and unobstructed) a means of manually isolating and locking out the power supply without breaking the true earth (ground) connection.

Removable plug and socket connection is not permitted under any circumstance.



WARNING – LETHAL VOLTAGE PRESENT

Lethal voltage may be present in this equipment when electrical power is applied. There is a danger of death or injury from electrical shock. Isolate power before opening electrical access panels. Ensure residual current is fully discharged before touching live terminals.



WARNING – LETHAL VOLTAGE PRESENT

Lethal voltage may be present both internally and externally to the system.

All installations, including cabinets, racks and remote units, must be connected to true earth, and must be capable of staying earthed (grounded) when the power supply is interrupted.

The Protective Earth (Ground) symbol is shown on the left, and it *always* has a green background.

Do not confuse it with the chassis earth symbol shown below it.



WARNING – TOXIC WASTE AND HARMFUL BY-PRODUCTS

Toxic waste and harmful by-products may accumulate within parts of the system. Suitable respiratory, eye and skin protection should be worn when servicing these items. Stringent industrial hygiene precautions should also be taken. Do not allow non-essential personnel into the work area.

The Touchpoint Pro system and/or its sensors may become contaminated by the ambient environment in which it or they are used. It is the Customer's sole responsibility to ensure that all appropriate safety precautions are taken before handling any components or transferring them to any other party.

SAFETY

Safety Hazards (continued)



WARNING – EYE HAZARD

The Touchpoint Pro system may contain sealed lead-acid batteries that may pose an eye hazard if the batteries have become damaged or pressurised. Always wear suitable eye protection when handling the UPS or batteries, or when clearing up chemical spills.



CAUTION – CORROSIVE

This equipment may contain batteries containing corrosive substances that may pose a health or environmental hazard if improperly handled or carelessly disposed of.



CAUTION – HEALTH AND ENVIRONMENTAL HAZARDS

This equipment contains a number of potentially toxic substances that may pose a health or environmental hazard if exposed to very high temperatures, VOCs or corrosives, or if improperly handled or carelessly disposed of.



CAUTION – RISK OF PERMANENT EYE AND BODY DAMAGE

Always wear suitable eye protection and PPE when installing or removing the Touchpoint Pro system, or any of its components.

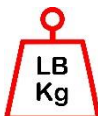

CAUTION – RISK OF INJURY AND DAMAGE

Touchpoint Pro enclosures are heavy and may become unstable when moved. Always wear PPE and ensure that mechanical means and sufficient personnel are available to assist when moving or handling these items.

Contact your Honeywell authorised representative if you need further advice on any of the above.

SAFETY

2.2 Location and Description of Warning Labels

2.2.1 Safety Warning Labels

Warning labels are mounted in specified locations on the equipment. This is to indicate conditions under which the user could be subjected to electrical or other hazards.



Figure 1. Electrical Warning Label 1



Figure 2. Electrical Warning Label 2



Figure 3. Protective Earth (Ground) Point



Figure 4. Equipment Earth (Ground) Point

Note: Earth (Ground) Location Point labels are used inside the system and are not normally visible to the operator.

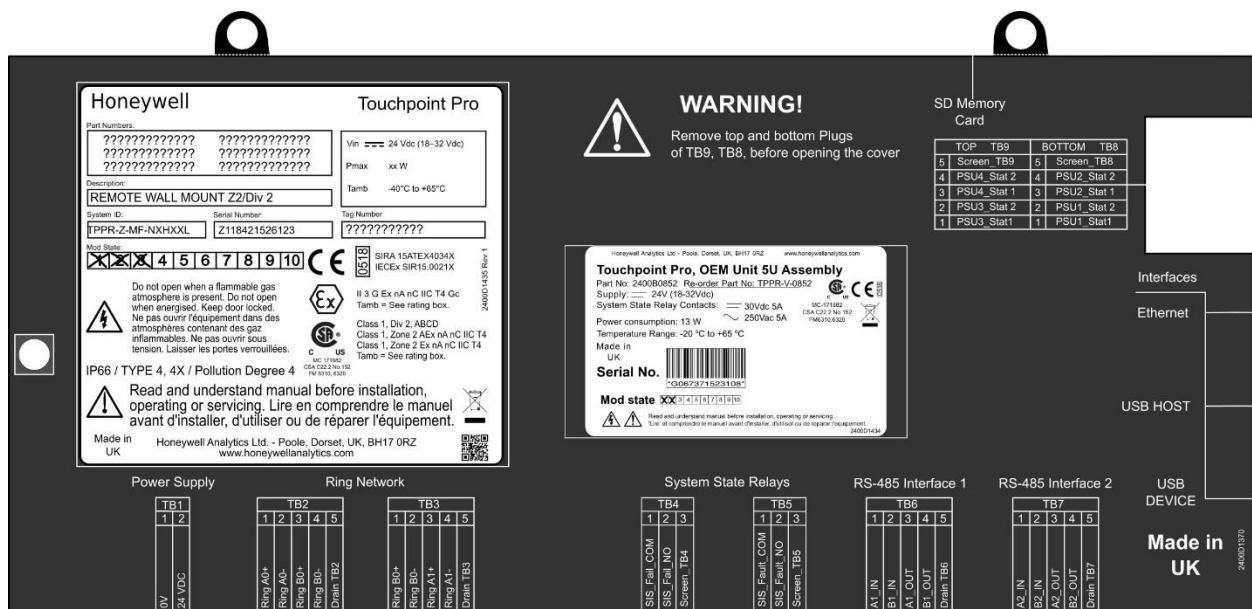

Figure 5. Controller Rear Cover with Example Labels

See next page for further information.

SAFETY

2.2.2 Equipment Rating Labels (Hazardous Locations)

The following labels are fixed in prominent positions on the enclosure and on relevant modules. It is the user's responsibility to check individual rating plates before installation and to ensure that specifications are not exceeded during operation. Exceeding the approved ratings invalidates product certification and the manufacturers' warranties.

Some controllers may not have the label shown in Figure 6, but will have a label similar to the one in Figure 7.

Key	
1	Manufacturer
2	Part Numbers
3	Description
4	ID and Serial Number
5	Modification State
6	Safety Warnings
7	Ingress Ratings
8	Manufacturer Details
9	Equipment Title
10	Limits for Voltage / Power / T _{amb}
11	CE Mark and Notified Body for Production Supervision
12	SIRA ATEX / IECEx Certificate Numbers
13	ATEX / IECEx Hazardous Area Certification Details
14	US/Canadian Hazardous Location and Zone Certification Details
15	CSA Monogram Canada and USA Certified
16	Manufacturer's Master Contract Number and Canadian / US Performance Identification

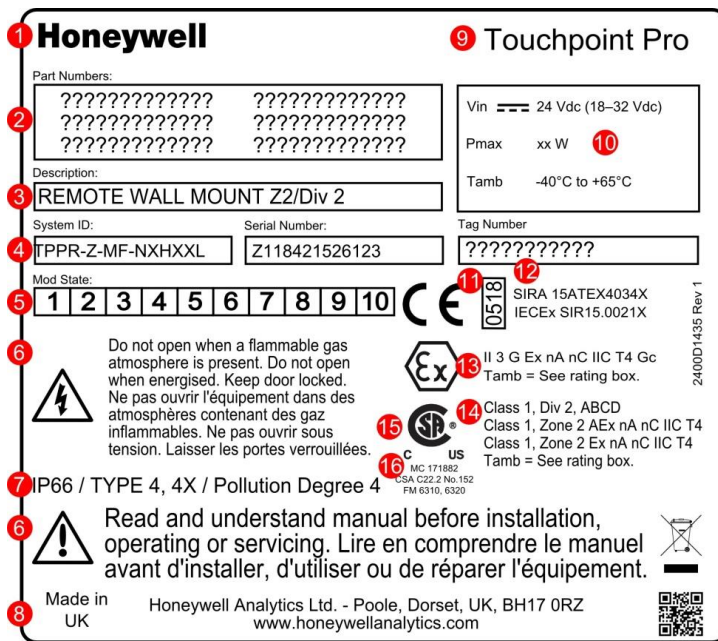

Figure 6. Example of a Typical System Rating Label

Note: The CE mark and Notified Body number 0518 shown on product labels does not apply to Type 'n' approval.



Figure 7. Typical TPPR Product Label

Note: Similar labels appear on the Modules and the Backplanes.

SAFETY

2.2.3 Warning Labels

The following symbols may be found on product labels and on the backup batteries:



Figure 8. Keep Children Away



Figure 9. No Naked Flames



Figure 10. Use Caution

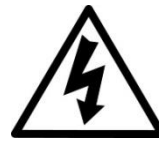

Figure 11. Electrical Hazard



Figure 12. Read The Instruction Manual



Figure 13. Wear Eye Protection



Figure 14. Hazardous Waste
(Pb = Lead)



Figure 15. Recycle Only

INTRODUCTION

3 Touchpoint Pro Introduction

Touchpoint Pro (TPPR) is a Command and Control System designed for the Honeywell Analytics' (and third party) range of fixed sensors and detectors. It provides constant sensor monitoring with automatic alarm response and notification. Its alarm levels and responses are fully customisable and all events and errors are logged on a removable SD card for easy archiving.

TPPR is certified to monitor hazardous areas such as Zone 2 Div. 2 via remote Z2D2 enclosures.

TPPR can be used indoors or outdoors, in pollution degrees 2 to 4, and up to IP66, depending on the enclosure that is used.

In addition it can be securely networked and either controlled or monitored via a secure network connection and the Honeywell PC Configuration software or via the secure Honeywell Webserver browser interface.

Note: Both access methods are optional licensed extras. Please visit the Honeywell website for further information or to download the Operating Instructions.

3.1 TPPR Access Levels

The table below details the access levels for the Local User Interface (UI). Broadly speaking, an **Administrator** can commission modules and configure channels, an **Engineer** can edit channel configuration and do calibrations and testing, and an **Operator** can acknowledge and reset events during normal day-to-day operation. Other users can view current and historical events and trend data, and generate reports.

TPPR is supplied with a default **Administrator** level account. For security reasons this password will be attached to the system Touchscreen. When the system is configured, at least one new **Administrator** account should be created. The default **Administrator** should then log out and then log back in as the new **Administrator**, and should then delete the default **Administrator** account to prevent unauthorized access. The **Administrator** can create other users with **Administrator** level access or lower and the Maintenance **Engineer** can create users with **Engineer** level access or lower.

Note: Forgotten or deleted passwords cannot be recovered so it is advisable to keep a copy of the master password in a secure place or have two **Administrator** accounts.

Authorised users can carry out the following tasks:

Key: Yes ●, No ○ Read only ■ Engineer and Operator ◆

Task	Administrator	Engineer	Operator
Basic System Setup	●	●	○
Change Language	●	●	○
Change My Password	●	●	○
Configuring Channels	●	●	○
Configuring Modules	●	●	○
Configuring System	●	●	○
Diagnostics	●	●	○
Help / User Guides	●	●	●
Licence Management	●	◆	○
User Management	●	●	■
View and accept and reset System Events	●	●	●
Generate Reports	●	●	●

Table 1. TPPR Access Levels

Note: Only **Administrators** can end another user's active session.

Note: For security reasons some of these tasks are unavailable through PC Configuration and Webserver software. Refer to the appropriate User Manual for more information.

Note: TPPR's ability to Accept and Reset events can be restricted to authorised users by changing the software settings. However, remote switches cannot be restricted through software so alternative switch protection methods should be used where required.

INTRODUCTION

3.2 TPPR Control System Layout

The TPPR Control system can be built from just four main building blocks:

1. One Controller module with colour LCD touch screen User Interface
2. One backplane power and communications rail (per enclosure or rack)
3. Power Supply modules (AC/DC, DC-UPS, Redundancy, Backup Battery)
4. Plug-in Input / Output (I/O) modules (mV, mA, AIM, DIM, ROM, Modbus)

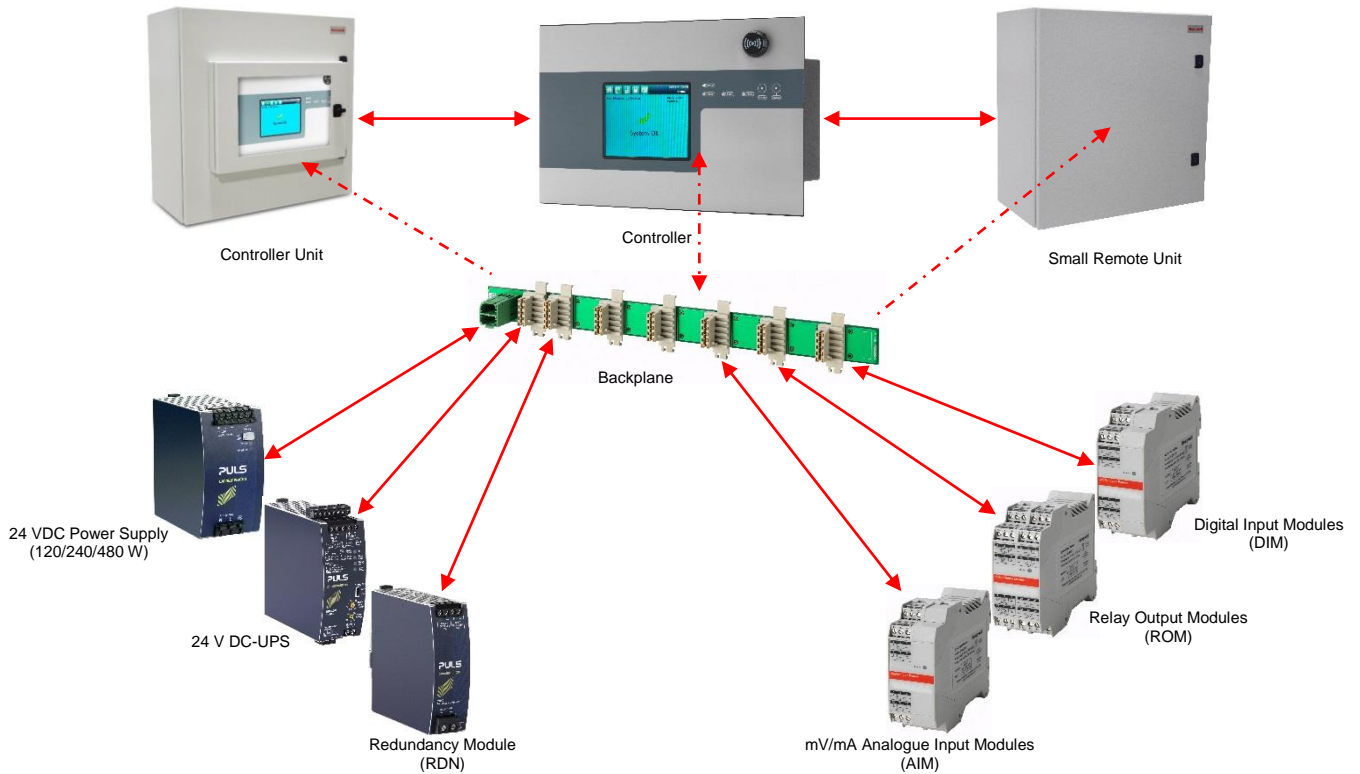

Figure 16. TPPR Building Blocks

The illustration above shows wall mounted units but rack mounted and floor standing units use the same building blocks. Enclosures can also hold multiple backplanes to allow for future system expansion.

INTRODUCTION

3.2.1 Centralised Command and Control Option

TPPR can be installed as part of a centralised cabling system. With a centralised system, the field devices are individually cabled back to the Controller and the field devices' distance from the controller is limited only by the cable resistance and whether or not power boosters are used.

3.2.2 Distributed Command and Control (Remote Units) Option

TPPR can be installed as part of a distributed cabling system. In a distributed architecture, the field devices are connected via short cable runs to TPPR Remote units, which are connected back to the controller by the Ring Network.

Remote units can be located up to 1 km (cable length) from the TPPR Controller or from each other, with a maximum cable loop of 3 km for the complete system. The only connection required between the Controller and the Remote units is the shielded network cable itself.

The TPPR Remote unit can be housed in any of the standard Enclosures, a 19" 5U rack, or a suitable 3rd-party enclosure. They do not need a Controller but they do require their own power supplies.

Note: Standard Remote Units can be sited in safe areas to monitor and control devices sited in hazardous areas. You should comply with all relevant legislation and you should follow the field device manufacturer's installation and use instructions.



WARNING

You can install a Zone 2 Remote unit in Zone 2 to monitor sensors in ATEX Zone 1 provided that you use appropriate barriers and armoured conduits, and that you follow all national and international cabling regulations.

The diagram below shows an example of a typical distributed setup showing both safe zone and zone 2 remote units.

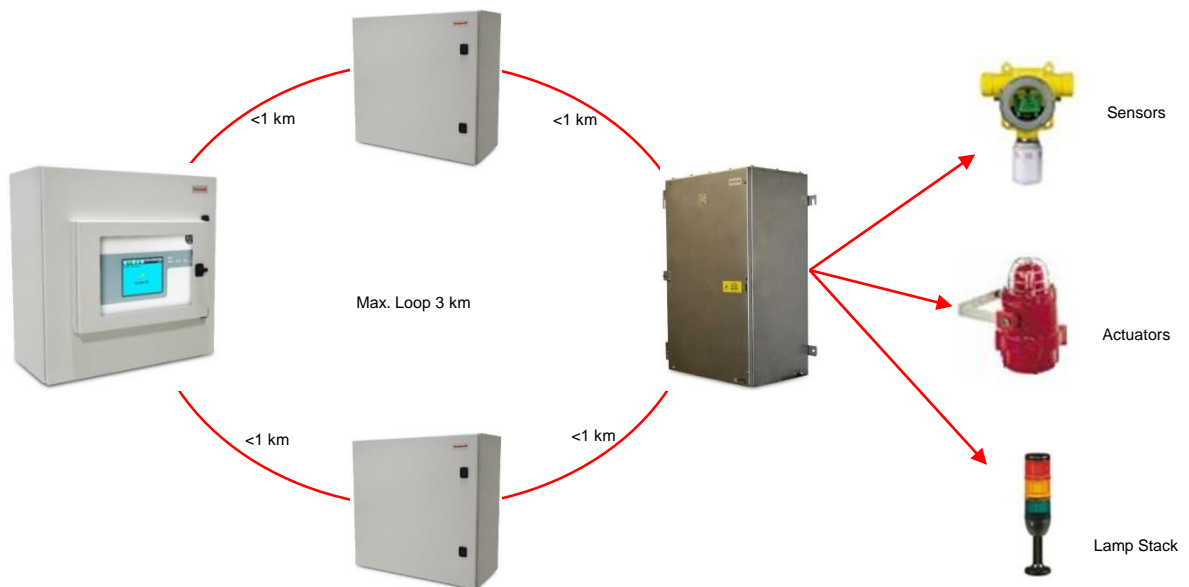

Figure 17. TPPR Controller with Remote Units and Field Devices

INTRODUCTION

3.3 TPR System Key Components

3.3.1 Enclosures and Racks

TPPR can be mounted in various sizes of floor or wall mounted enclosures, or on 19" 5U racks. The floor mounted enclosures can be unventilated, naturally ventilated, or force ventilated. The fully sealed wall mounted enclosures can hold a controller or can be a remote terminal without a controller.

If using a 19" rack, the OEM or installer must ensure the installation is at least IP20 / Type 1 / Class 1 (grounded) to mitigate the risk of electrical shock.



Figure 18. TPPR Enclosures

3.3.2 TPPR Controller User Interfaces

The TPPR Controller is covered with a protective membrane and houses the touch screen user interface (UI), the alarm buzzer, the Accept and Reset buttons, and coloured LEDs for Power, Alarm, Fault, and Inhibit.

The controller has four access methods:

- Control Panel touch screen for normal system operation, maintenance and configuration
- PC Configuration Software (optional licences) for secure maintenance and configuration over a VPN or cable
- Webserver (optional licences) allows up to 5 people to securely view events and carry out basic system operation via an Ethernet connection or the Internet
- Modbus option

Internal System Interfaces consist of:

- Two master relays that signal System Failure and System Fault
- Connections for one SD Card and one USB drive
- 10/100 Mbps Ethernet connection (for networked interfacing)
- Optional dual RS 485 Modbus RTU interface

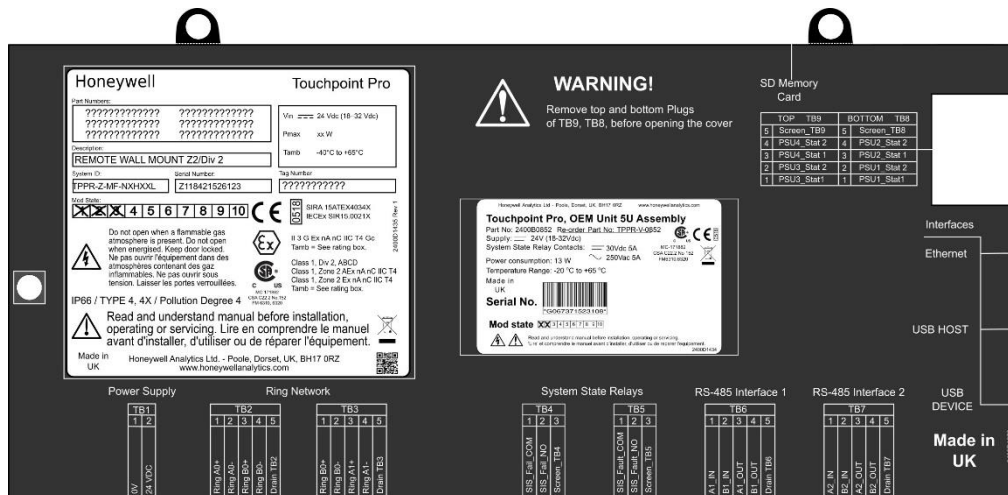

Figure 19. TPPR Controller Cover with Connection Map

INTRODUCTION

3.3.3 SD Card

TPPR is supplied with an installed 4Gb SD card, which users may replace with a larger capacity if desired.

The SD card is used to store the event history of the system. TPPR logs all events and all changes to input readings.

Note: The SD Card should remain inserted during normal system operation as the motherboard has limited data storage capacity.

3.3.4 USB Port

The **USB Host** port allows users to save reports, backup and restore configuration.

Note: USB devices must be formatted to **FAT32** only; other file systems are not supported and will not work.

Note: The USB device is intended for maintenance and support operations only, and should be removed for normal use.

3.3.5 PC Configuration Software

This optional (downloadable) licensed software allows authorised users to configure some TPPR settings by using a remote PC over an Ethernet connection. This is more efficient as you can use a larger screen and keyboard.

More information is available in a separate PC Configuration Operating Manual.

3.3.6 PC Operating Systems

Windows 7 is supported for use with PC Configuration software.



CAUTION

Honeywell will not be held liable for any loss or damage caused by any security breach, no matter how caused.
Windows XP is considered a high security risk and is not recommended.

3.3.7 Webserver Software

This optional (pre-installed) licensed software allows users to remotely view live status, and analyse event history. Authorised users can also acknowledge, inhibit and reset I/O channels.

The Webserver supports up to 5 concurrent web clients. More than 5 clients can connect but performance may degrade.

More information is available in a separate Webserver Operating Manual.

3.3.7.1 Supported Web Browsers

TPPR software is compatible with most current web browsers.

INTRODUCTION

3.3.8 Licences

The TPPR controller software does not require a licence.

Please contact your local Honeywell supplier or distributor to obtain licences for the optional PC Configuration and Webserver options.

Refer to the PC Configuration or Webserver User Guides for details on installing and managing licences.

TPPR will notify you shortly before the expiry of your current PC Configuration or Webserver licence. Licence expiry does not affect local operation using the local controller's interface.



CAUTION

Always follow the correct procedure to remove/suspend/reinstall a licence if your system software or firmware is going to be updated or repaired. Full details are contained in the PC Configuration and Webserver User Manuals.

3.3.9 TPPR Controller Hardware

Internally the Controller houses the Control Centre Board (CCB) and the Communications Board (COB). It also contains an SD Card slot, USB ports and an Ethernet / Printer port.

The CCB handles all functions related to the safety system operation, the Ring network, the LED indicators and buttons on the front panel, and the master system state relays. An optional backup CCB is available for multiple redundancy specifications.

The COB handles the remaining user interfaces – Touchscreen, SD, USB and the Ethernet and Modbus ports.

The Communication Board is completely independent from the Safety Function of the system.



Figure 20. TPPR Controller

INTRODUCTION

3.3.10 TPR Backplane

The TPR Backplane is the power and information highway to which all of the TPR modules are attached. There can be several backplanes in larger units, and they are installed within the DIN rail to which the modules are clipped.

The Backplane is available in four lengths (270 mm, 350 mm, 430 mm, 480 mm) to suit 5, 7, 9 or 10 I/O modules respectively, but the choice may be restricted by the size of the selected power supply option and the need to maintain adequate cooling space between modules.

Note: The DIN rail is 430 mm for a standard enclosure or 487 mm for the wide enclosure (10 x I/O) option.

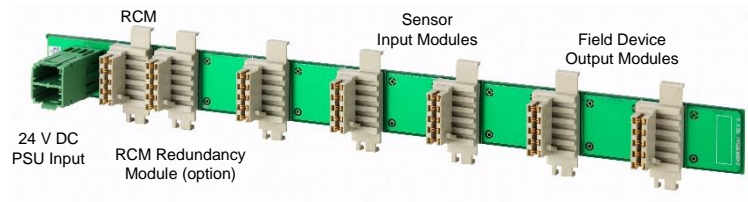

Figure 21. TPR Backplane

The Power Supply Unit (PSU) plugs into the green socket on the left hand side of the Backplane PCB, and it supplies power to the modules via the white connectors. The Ring Coupling Module (RCM) normally sits next to the Power Connector and handles all of the bi-directional communication between the CCB and the modules, again via the white connectors.

3.3.11 Ring Network

The Ring Coupling Module (RCM) and Input / Output (I/O) modules connect to a dual ring circuit so that they can communicate with the CCB through each other and through the RCM.

This enables fail-safe redundancy because, if one addressable module fails and interrupts the primary circuit, the addressable modules on either side of it can still communicate with the CCB via the backup ring circuit (see diagram below), and the CCB can identify which module has failed by knowing which addressable modules are still active.

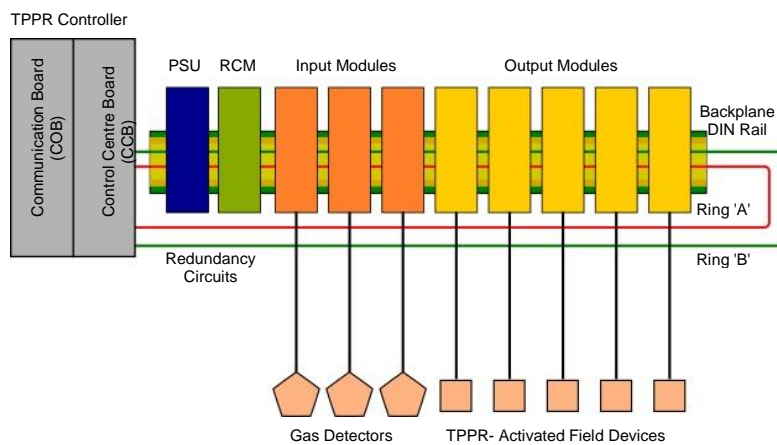

Figure 22. TPR Controller Typical Schematic

INTRODUCTION

For single cabinet installations, the Ring Network runs directly between the RCM and the Control Module.

For Remote units, the network runs additionally over data cable between the Controller and all of the backplanes in the system.

The Ring Network is the only communication link required between the CCB and Remote Units (which have their own backplanes, PSU and modules, but no Control Module).

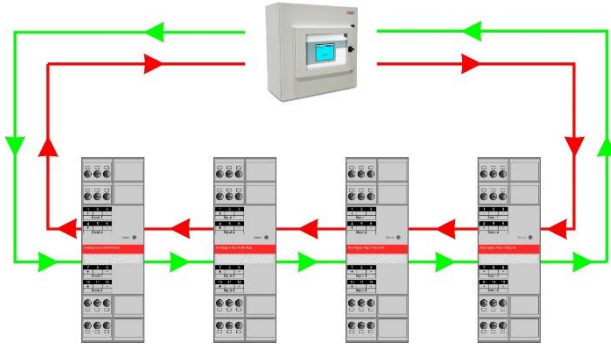

Figure 23. Ring Circuit With All Modules Working

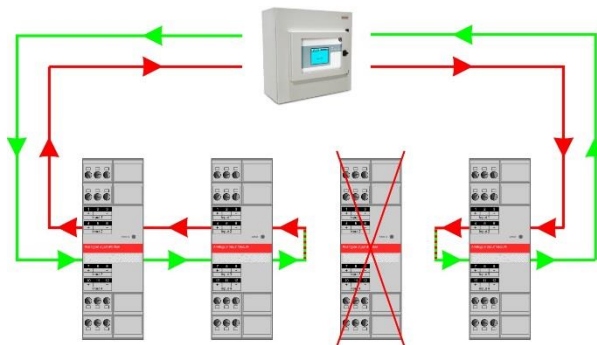

Figure 24. Ring Circuit With a Failed Module

Further information can be found in *Ch.19 Ring Communication Errors*.

INTRODUCTION

3.3.12 TPR Modules

TPPR is of modular construction so it can be easily expanded if required. The quantity and mix of I/O modules is optional and expandable.

- Power Supply Unit (PSU) modules accept AC 120 – 240 V at 50/60 Hz single phase and are available in three power outputs: 24 VDC @ 120, 240 or 480 W.
- The optional DC-UPS is an uninterruptible DC power supply that links to and charges the optional 2 x 12 V Sealed Lead Acid backup batteries.
- The optional Redundancy Module (RDN) can control two DC 20A power inputs. If one input supply fails, the Redundancy Module will switch over to the other, maintaining the DC output. Alarm relays will open if one of the input supplies fails.
- The Ring Coupling Module (RCM) enables fail-safe bi-directional (ring network) communication between modules and the controller. An RCM is required for each backplane in the system.

Various types of I/O modules are available, each containing four channels. A single TPR system can contain up to 16 input modules offering 64 input channels and up to 32 output modules offering 128 output channels.

Title	Description
Analogue Input Module 4–20 mA (AIM mA)	4-channel Analogue Input Module for 2 or 3 wire 4-20mA sensor signals
Analogue Input Module mV Bridge (AIM mV)	4-channel Module for mV-Bridge signals; supports up to 4 catalytic bead flammable gas sensors
Digital Input Module (DIM)	4-channel Module for switched input devices such as manually operated push buttons. Can also be used for remote access to alarm acknowledge, reset and output inhibit inputs
Relay Output Module (ROM)	4-channel Module incorporating qty 4 SPCO (NO/NC) relays; suitable to activate field mounted external alarms, actuators, drenching or shutter systems, or to de-activate magnetic exit controls etc.

Table 2. TPR Module Types



Figure 25. TPR Module Types

3.3.13 Sensor Catalogue

The TPR Controller is pre-loaded with an updatable sensor catalogue that lists all of Honeywell Analytics' current gas sensors, each with a full default configuration setting that can be loaded when commissioning the Input modules. The full configuration can be viewed afterwards, and individual parameters changed if desired.

The full procedure is explained in the Commissioning chapter.

INTRODUCTION

3.4 Power Supply Options

TPPR can be supplied from an AC 110/240 V Single Phase industrial supply via the optional Power Supply (PSU) Modules, or from a direct DC 24 V power supply, or from optional 24 VDC backup batteries via the DC Uninterrupted Power Supply module (DC-UPS).

When specifying power supplies, you should consider cabinet internal temperatures and cooling. In addition, power supplies should be rated to allow for current surges and peaks. Contact your Honeywell representative for advice.



WARNING

AC power supplies must have a permanent connection to a protective earth, according to local regulations.

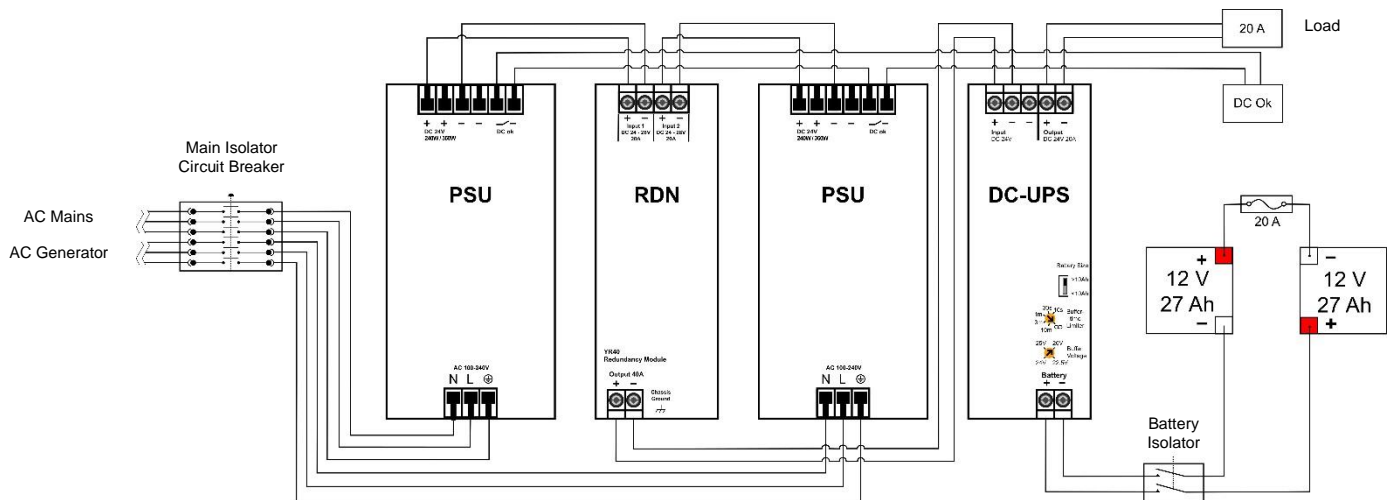

Figure 26. Typical Power Supply Setup

A full description of the available module types is given in the following sections.

3.4.1 Power Supply Unit Modules (PSU)

The TPPR System can be equipped with PSU modules of different capacity, depending on the number of I/O modules being used. The power supplies are mounted to the DIN-Rail and are available in the following ratings:

- 120/180 W, 24 – 28 VDC (5 A @ DC 24 V)
- 240/360 W, 24 – 28 VDC (10 A @ DC 24 V)
- 480/720 W, 24 – 28 VDC (20 A @ DC 24 V)

The power supplies have a 'DC Ok' status output that can be used to give a fault warning on failure.



Figure 27. Choice of PSU Size (120 W / 240 W / 480 W)

INTRODUCTION

Terminal	Purpose
N	~ AC 110/240 V Neutral In
L	~ AC 110/240 V Line In
	Protective Earth (Ground)
+	⋯ DC 24 – 28 +V Output 1
+	⋯ DC 24 – 28 +V Output 2
-	⋯ DC -V Output 1
-	⋯ DC -V Output 2
DC OK	⋯ Relay Contacts 1 & 2

Table 3. PSU Terminal Allocation

3.4.2 Power Redundancy Module (RDN)

The RDN is an optional power supply backup system that can be installed with a second PSU to offer dual power supply redundancy. Often the Mains supply will be connected to the first PSU and a stand-by generator connected to the second PSU. The RDN will take power from either input and output it as a single source. See diagram below for cabling details.

Note: The RDN Output can also provide further redundancies via an optional battery backup and DC Uninterruptible Power Supply (DC-UPS) module.

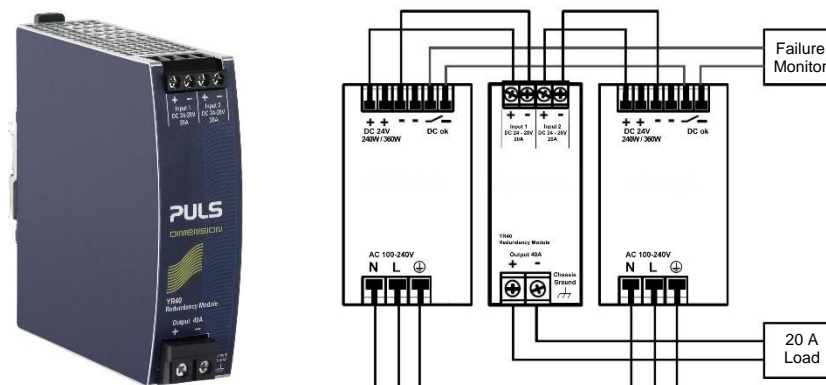

Figure 28. Power Redundancy Module Operation

INTRODUCTION

3.4.3 DC Uninterruptible Power Supply (DC-UPS) Module

The DC-UPS Module can be used with the separate and optional TPPR Battery Enclosure to provide continuous and uninterrupted power to the TPPR in the event of an external power failure.

The DC-UPS is adjustable for buffer time and buffer voltage, and carries red, yellow and green status LEDs and descriptions that show your backup battery status (see tables below).

Note: The DC-UPS Module Buffer Voltage should be set at 26 VDC to ensure optimum battery charging, and the Buffer-time Limiter should usually be set to ∞ (see circled area on the figure below).

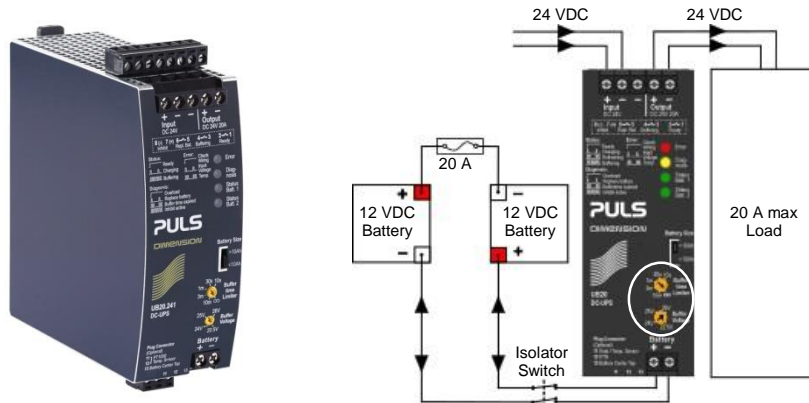

Figure 29. DC-UPS and Battery Configuration

The DC-UPS terminals are as follows:

DC-UPS Terminal	Purpose
Input +	+24 VDC input from UPS
Input -	-24 VDC input from UPS
Input -	-24 VDC input from UPS (spare)
Output +	+24 VDC output to 20 A (max) Load
Output -	-24 VDC output to 20 A (max) Load
Battery +	+24 VDC Battery in/out
Battery -	+24 VDC Battery in/out

Table 4. DC-UPS Primary Terminal Allocation

The DC-UPS also has Normally Open (NO) relay terminals that can be used for external repeaters such as a lamp stack or alarm buzzer, as shown in the table below:

DC-UPS Terminal	Purpose
1 & 2	Ready relay: Closed when all is Ok (green)
3 & 4	Buffering relay: Closed when batteries are supplying power (yellow or buzzer)
5 & 6	Replace Battery relay: Closed when batteries fail load test (red or buzzer)
7 & 8	Do not use as Inhibit belongs to the Controller only
11 - 13	Not normally used

Table 5. DC-UPS Secondary Terminal Allocation

INTRODUCTION





LED Flash	Green Status LEDs	Yellow Diagnosis LED	Red Error LED
	Steady means DCUPS ready	Steady means Power Overload	Steady means Check the wiring
	Single flash means Charging	Single flash means Replace Batteries	Single flash means Check Input voltage
	Double flash means Refreshing	Double flash means Buffer time expired	Double flash means Over Temperature
	Continuous flashing means Buffering	Continuous flashing means Inhibit Active	—

Table 6. DC-UPS LED Meanings

3.4.4 Backup Batteries

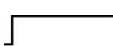
The optional Battery Enclosure contains two rechargeable 12 V batteries wired in series to give a nominal 24 VDC supply. The batteries can be either 12 Ah or 27 Ah and they are overload-protected by a 20 A fast acting inline cartridge fuse.

A new set of 12 / 27 Ah batteries should supply 22.5 V at 20 A for up to 16.75 / 32 minutes respectively, depending on the connected load. However, you should be aware that all batteries deteriorate over time, and Honeywell recommend that you check and replace them regularly to ensure optimum performance in an emergency.

Note: Always switch the Battery Isolator switch to **Off** before carrying out any work on the battery circuit, and ensure it is **On** when work is completed.

The 12V monobloc batteries are Valve-Regulated Lead Acid (VRLA) Absorbed Glass Mat (AGM) batteries that:

- Are optimized for discharge (buffer) times of up to 20 hours @ 3 A.
- Have a 5 year design life in float operation in temperature controlled environments.
- Have VRLA AGM and gas recombination technology with 99% internal recombination.
- Are non-spillable and maintenance free.
- Are non-hazardous when packaged for air/sea/rail/road transportation.
- Are 100% recyclable.



12 / 27 Ah Battery (pair)	Stand-by Use
Charge Voltage (max)	27 V
Input Current	3 A
Max Output Current	20 A
Max Load	30 A <4 Sec.
Fuse type (inline)	20 A Fast Acting Tube
Current Limit Protection	20 A Double-pole Circuit Breaker / Isolator,
Weight 12 Ah	3.75 kg (ea.)
Weight 27 Ah	8.5 kg (ea.)



Table 7. Backup Battery Details

INTRODUCTION

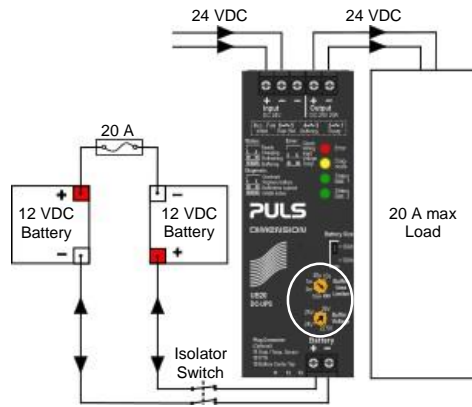

Figure 30. Battery Circuit

MECHANICAL INSTALLATION

4 TPPR Mechanical Installation

Mechanical installation consists of physically mounting the TPPR Enclosure on a wall or, for floor mounted enclosures, on a suitable plinth, and then fixing cable trays in appropriate locations. Electrical Installation is covered in the next chapter.

4.1 TPPR Siting Considerations

TPPR can be installed in a wide range of wall floor and rack mounted enclosures but you should always consider the following when choosing locations:

- TPPR is specified for operation in ambient temperatures from -20°C to +55°C (TPPR Controller) or -40°C to +65°C (no Controller). However the upper ambient temperature may be reduced dependent on the type and quantity of installed components. It is the user's responsibility to check the equipment rating plates for the true ambient range of the installation as operation outside of this temperature range invalidates the warranty and certification.
- All enclosures and racks have individual Ingress Protection and type ratings. It is the user's responsibility to check individual rating plates for requirements.
- Only Zone 2 Div. 2 and Remote enclosures can be installed outside in unprotected locations. See *Ch.20 TPPR Specifications* for further details.
- TPPR enclosures shall be protected from direct sunlight where exposure could cause the unit temperature to rise beyond the specified operating limits, or where UV light could damage the Controller's membrane or Touch screen. It is the installer's responsibility to ensure that the unit temperature does not rise beyond the specified operating limits.
- The TPPR wall mounted enclosure shall be installed only on a vertical surface and floor mounted enclosures shall be installed only on a suitable weight-bearing plinth. Use the mounting fixtures supplied with the apparatus plus any specialist fixtures determined by the location, and follow the installation instructions carefully.
- The mounting surface should be flat, and strong enough to bear the weight of the TPPR system. Solid brick type construction is recommended, while drywall / plasterboard, dry lined or timber framed type construction is not considered to be a suitable structural material unless appropriately reinforced. Take account of the contents and external cabling in addition to the weight of the wall mounted enclosure itself (check maximum enclosure weights detailed in the next section).
- There must be sufficient clearance to mount the wall mounted enclosure and be able to fully open the door. A minimum clearance of 100 mm all round plus space for cable entries is required. The door hinge is on the left side. Beware of proximity to entries, exits and sloping ceilings.
- If more than one enclosure is to be used, ensure that there is sufficient clearance between the enclosures for cable glands, mounting, cooling, door opening etc. **This applies especially when mounting the backup battery enclosure beneath the TPPR Controller Enclosure.**
- Ensure that the TPPR interface and touch screen can be freely viewed and reached. A wall enclosure touch screen height of approximately 1.5 m is recommended for comfort, but the height of a floor mounted enclosure will be determined by the enclosure size and height of the plinth.
- Beware of siting TPPR in vehicle movement areas as personal injury may result. Erect safety barriers if this is unavoidable.
- TPPR conforms to the requirements of European and other standards for EMC and RFI. It should not be installed in close proximity to the antennae of high power radio, radar and satellite communication equipment, or in the vicinity of high voltage switching gear or overhead power lines.
- All signal cables should be shielded and bonded to protect them from stray or induced current.

MECHANICAL INSTALLATION

4.2 Installing Wall Mounted Enclosures

The TPPR Controller and Remote units can be installed in a wide range of wall mounted enclosures.



CAUTION

Touchpoint Pro enclosures are heavy and unwieldy (refer to *Specifications*) and a single person lift is not recommended. Before lifting the enclosure, consider and implement control measures to reduce the risk of injury. Refer to local safety regulations.



CAUTION

It is the installer's responsibility to select the appropriate fixings while taking into account the structure of the mounting surface and the weight of the specific enclosure.
Wall mount and plinth fixing bolts should be a minimum 8 mm dia. x 50 mm depth.

The TPPR wall mounting brackets must always be installed in a vertical orientation as shown below.

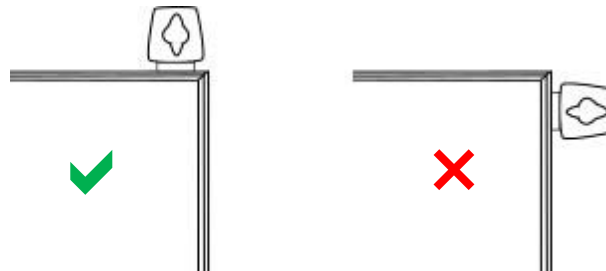

Figure 31. TPPR Correct Enclosure Mounting Orientation

4.2.1 Wall Mounted Enclosure Weights

The following table shows approximate weights for various wall mounted enclosures, but this should only be viewed as an example as the exact enclosure weight depends on the custom configuration of Controller and modules. System weights will be given on the shipping note.

Description	Approximate Weight in kg
600 x 600 x 300 mm powder coated steel enclosure with Controller	41
600 x 600 x 300 mm powder coated steel enclosure no Controller	37
800 x 600 x 300 mm powder coated steel enclosure with Controller	50
800 x 600 x 300 mm powder coated steel enclosure no Controller	46
1200 x 800 x 300 mm powder coated steel enclosure with Controller	85
380 x 300 x 210 mm Backup Battery Enclosure (empty)	8
12 Ah Battery (pair)	7.5
27 Ah Battery (pair)	17

Table 8. Approximate Wall Mounted Enclosure Weights

MECHANICAL INSTALLATION

4.2.2 Wall Mounted Enclosure Dimensions

The dimensions of the various wall mounted units (Controller or Remote) are shown below (all dimensions in mm):

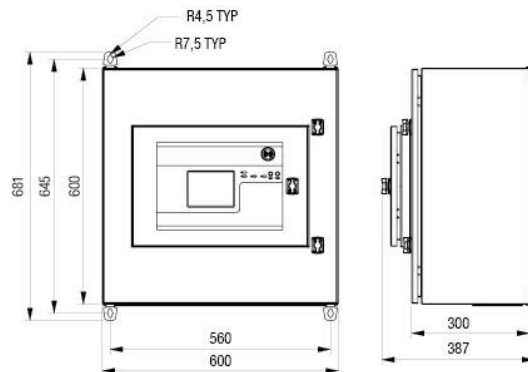

Figure 32. Small Wall Mounted Enclosure

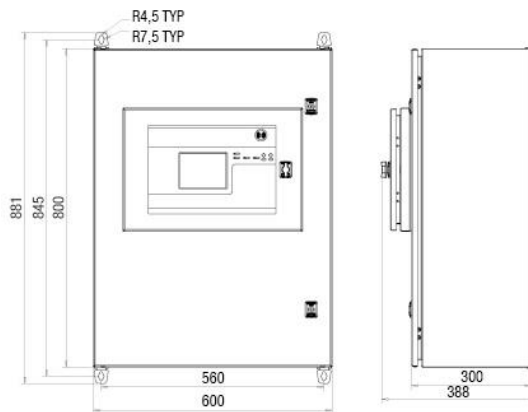

Figure 33. Medium Wall Mounted Enclosure

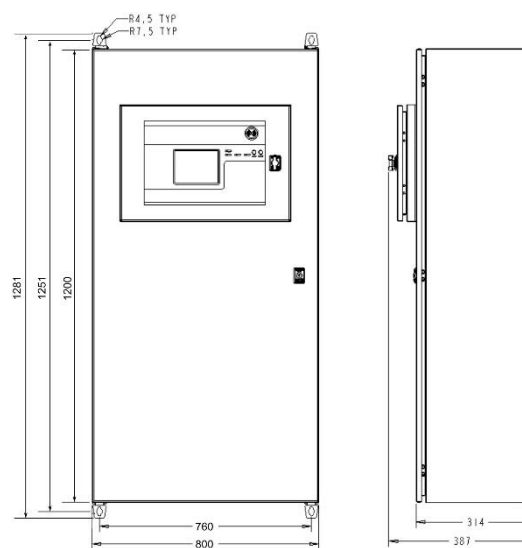

Figure 34. Large Wall Mounted Enclosure

MECHANICAL INSTALLATION

The following unit is certified for use in hazardous areas/locations ATEX/IECEX II 3G Ex nA IIC T4 Gc or CSA Zone 2, Class I Div. 2, and Class I (Zone 2). This enclosure can only be used as a remote unit as no controller option is available.

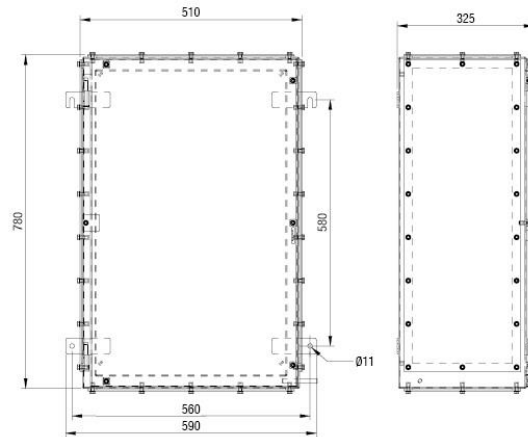

Figure 35. Hazardous Area Wall Mounted Enclosure

4.3 Installing Floor Standing Enclosures

The TPPR Controller can be mounted in a range of large powder coated steel floor mounted enclosures, either fully enclosed or with or additional natural or forced ventilation.

All enclosures are approximately 2000 x 800 x 600 mm (without ventilation hood and lifting lugs) and weigh >230 kg. See the shipping note for accurate details.

Note: Optional air vents can be fitted to front or rear doors depending on whether front or rear cable access is used.



CAUTION

Users shall not allow the ventilation to become blocked or subjected to moisture ingress as this will void certification and the warranty, and may cause irreparable damage.

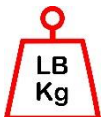

CAUTION

Touchpoint Pro enclosures are heavy and unwieldy (refer to *Specifications*) and a single person lift is not recommended. Before lifting the enclosure, consider and implement control measures to reduce the risk of injury. Refer to local safety regulations.

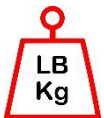

CAUTION

It is the installer's responsibility to select the appropriate fixings while taking into account the structure of the mounting surface and the weight of the specific enclosure.



CAUTION

Due to their size and weight, floor mounted enclosures must stand on a minimum 100 mm thick purpose built plinth, and must be securely fixed to either the plinth or wall.

Wall and plinth fixing bolts should be a minimum 8 mm dia. x 50 mm depth.

MECHANICAL INSTALLATION

4.3.1 Floor Standing Enclosure Dimensions

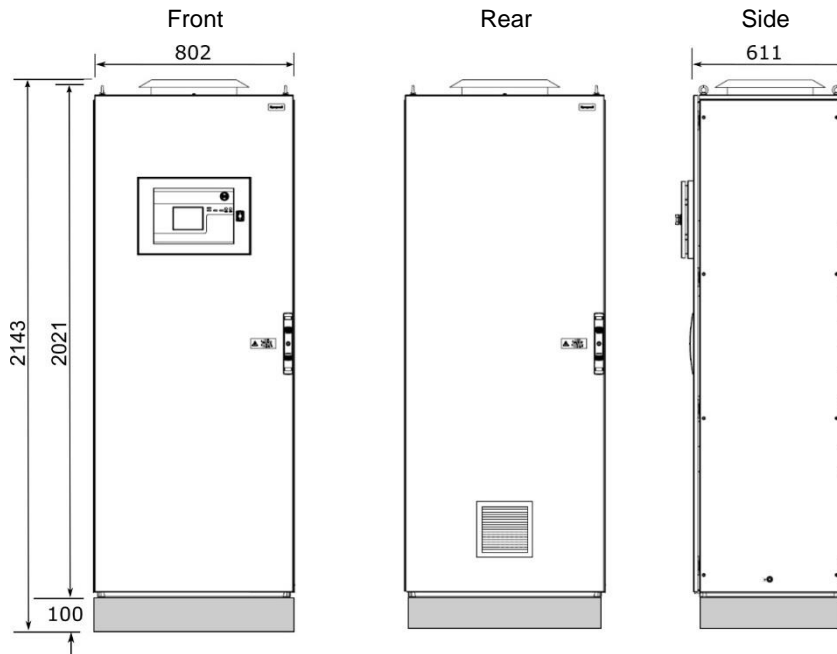

Figure 36. Example of a Floor Mounted System with Forced Rear Ventilation and Vent Hood

4.4 Installing the TPRR 19". Rack Mounted Unit

This module is designed to fit into an industry standard 19" rack, with a height of 5U. The dimensions of the 19" rack mounted unit (Controller or Remote version) are shown below (all dimensions in mm).

Note: It is the OEM and Installer's responsibility to ensure that the unit is electrically and environmentally safe and is protected against the ingress of dust or moisture.

4.4.1 TPRR 19" Rack Mounted Unit Dimensions

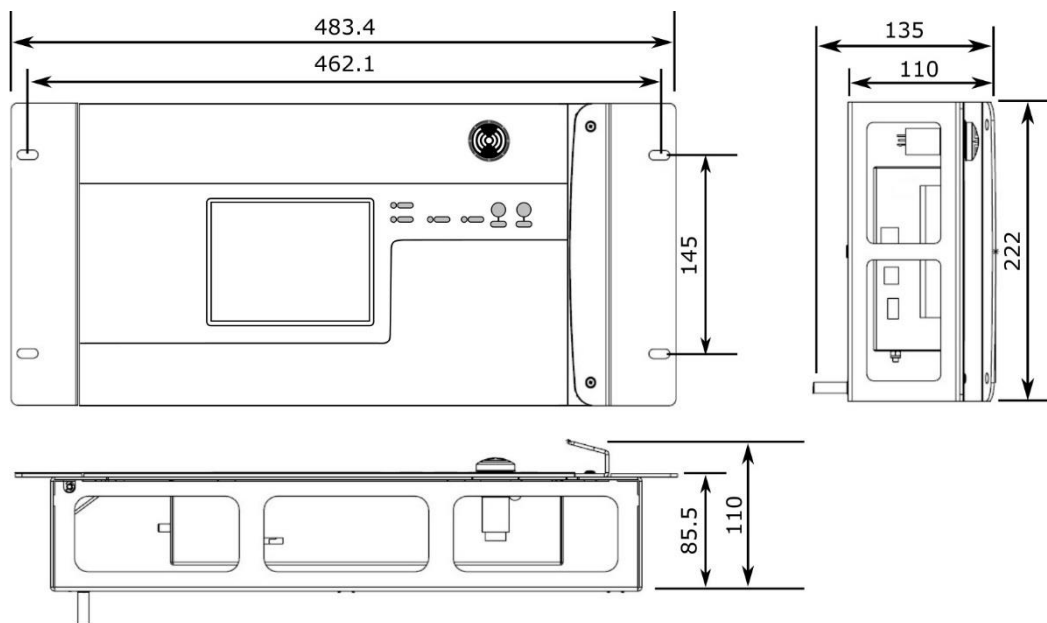

Figure 37. TPRR 19" Rack Dimensions

MECHANICAL INSTALLATION

4.5 Installing the TPR Panel Mount Controller

This module is designed to be fitted into a custom panel. It has a height of 5U and a bezel mounting kit is available. The dimensions of the unit are given below (all dimensions in mm), and the panel cut-out hole should be (w x h) 368 x 232 mm.

Note: It is the OEM and Installer's responsibility to ensure that the unit is electrically and environmentally safe and is protected against the ingress of dust or moisture.

4.5.1 TPR Panel Mount Controller Dimensions

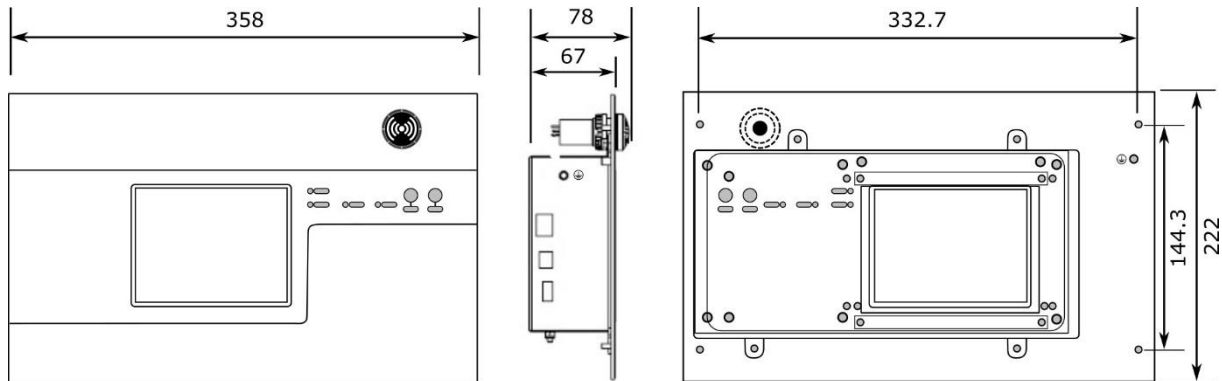

Figure 38. TPR Panel Mount Dimensions

4.5.2 TPR Controller Mounting Bezel Option

There is an optional bezel mounting unit available when mounting the Controller in a custom enclosure.

Note: The bezel mounting nuts must be tightened in the correct order and to the correct torque settings. Incorrect tightening will result in distortion of the front panel membrane so refer to the documentation supplied with the mounting kit, or contact Honeywell for advice.

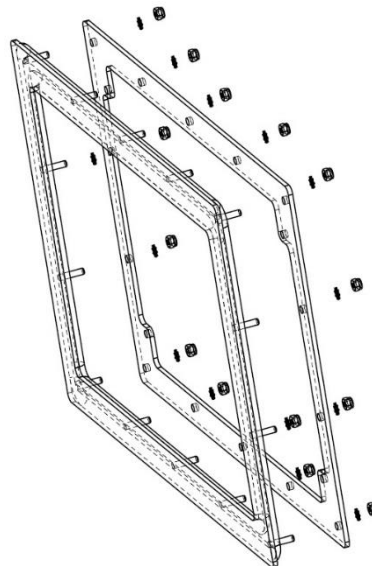

Figure 39. TPR Bezel Mounting Kit

MECHANICAL INSTALLATION

4.6 Installing the Battery Enclosure

Battery Enclosure installation is described in a logical sequence starting with assembling and mounting the optional battery enclosure followed by assembling and fitting the batteries.

Batteries are classified as hazardous goods and must be shipped in their own packaging. It is therefore necessary for the customer to install the batteries into the enclosure *after* the enclosure is securely mounted.



CAUTION

Prior to starting mechanical installation, it is recommended that you take into account that the DCUPS to Battery Enclosure Circuit Breaker / Isolator cable is limited to a maximum of 5 m of 4 mm² cable, and that you position the enclosures accordingly before making any permanent fixings.



CAUTION

The TPPR Battery Enclosure must be installed in a Pollution Degree 2 environment as defined by IEC 61010-1 (CSA-C22.2 No 61010, ANSI/ISA 61010-1(82.02.01)), i.e. an environment such as an office or control room.



CAUTION

The TPPR Battery Enclosure is specified for operation in ambient temperatures from -20°C to +45°C. Operation outside of this range invalidates the warranty and certification.



CAUTION

Ensure that there will be unobstructed access to the Circuit Breaker / Battery Isolator switch inside the enclosure, and that there will be sufficient room to fit or remove the batteries when required.



CAUTION

The backup batteries have a limited shelf life, so please ensure that the batteries are connected and fully charged within 3 months of delivery.

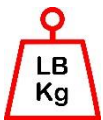

CAUTION

Fix the battery enclosure securely to the wall before installing the 7.5 kg (12 Ah x 2) or 17 kg (27 Ah x 2) batteries.

Note:

- The TPPR Battery Enclosure should be installed only on a vertical surface and avoiding sloping surfaces. Only use the mounting brackets supplied with the enclosure, and carefully follow the installation instructions below.
- The mounting surface should be flat, and strong enough to bear the weight of the Enclosure with the batteries installed. Drywall / plasterboard, dry lined or timber framed type construction is not considered to be a suitable structural material, unless strengthened with additional supports or braces and/or special fixings. Take into account the weight of the batteries and external cabling in addition to the weight of the unit itself.
- The TPPR Battery Enclosure should have a clearance of 200 mm to either side, and there should be no heat sources below or adjacent to it. Do not obstruct the air vents on either side.

MECHANICAL INSTALLATION

4.6.1 Assembling and Mounting the Battery Enclosure

The dimensions of the TPRR Battery enclosure and mounting points are shown below.

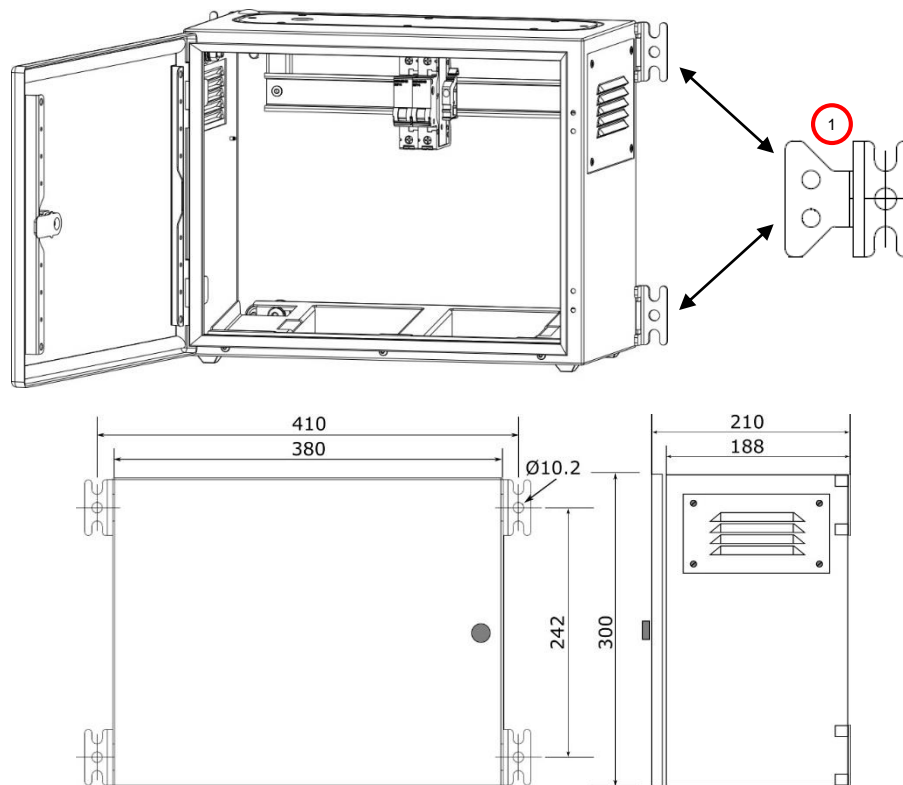

Figure 40. TPRR Battery Enclosure Dimensions

1. Insert the mounting brackets (1) into their mounting points. Fit the M6 bolts and torque to 6 Nm.
2. Identify the required cable entry point. Remove the cable gland plate and drill out the hole required for the cable entry. Support the cable gland plate to avoid distortion.
3. Fit the cable gland to the cable entry. The cable gland should be appropriate to the application and capable of maintaining the IP20 rating. The cable gland must provide anchorage and stress relief for the incoming cables.
4. Re-fit the cable gland plate.
5. Select a suitable mounting position for the enclosure, taking into account the siting considerations above.
6. Mark and drill four holes corresponding to the mounting hole positions.
7. Secure the Battery enclosure in place. The mounting holes are 10 mm in diameter. Fixing bolts should be a minimum diameter of 8 mm, and to a minimum depth of 50 mm.
8. Feed the TPRR DC-UPS battery supply cables through the gland and insert them into the enclosure Isolator / Circuit Breaker terminals.
9. Tighten the cable gland to prevent ingress of moisture.
10. Ensuring that both TPRR mains power and battery isolator are **Off**, connect the battery supply cables to the DC-UPS.

Note: It is the installer's responsibility to select the appropriate fixings while taking into account the structure of the mounting surface and the weight of the enclosure plus batteries i.e. circa 15.5 kg (12 Ah x 2) or 25 kg (27 Ah x 2).

MODBUS INSTALLATION

5 TPPR Electrical Installation



WARNING

Installation must be in accordance with the recognized standards of the appropriate authority in the country concerned. Refer to local, national and company regulations.



CAUTION

TPPR power supplies are supplied already wired. Do not modify any factory fitted cabling.

5.1 Power Requirements



WARNING

All power supplies must be hard wired and must include a suitable circuit breaker (RCD / RCCB), and (close by and unobstructed) a means of manually isolating and locking out the power supply without breaking the protective earth (ground) connection.

Removable plug and socket connection should not be used under any circumstance.

5.1.1 Power Consumption

The power consumption of your system was calculated when it was ordered. See the supplied Certificate of Conformity, or the fixed rating plate for details.

5.1.2 AC Power Input

AC Power input (if used) must be single phase AC 100 – 240 V, 50/60 Hz.

The mains supply requires an overcurrent protection rated in accordance with the rating plate on the specific system. The supply must be a fixed installation, i.e. not plug and socket.

The supply must be able to be isolated by means of a lockable switch or circuit breaker, which must be suitably located, easily reached and clearly marked as the TPPR disconnect device.

The wiring used between the isolator and TPPR must be appropriately rated and approved.

5.1.3 DC Power Input (excluding backup batteries)

External DC Power input (if used) must conform to the Input Supply Voltage given in *Ch.20 TPPR Specifications*, and it must not be located inside the TPPR wall mounted enclosure.

The voltage supply requires an overcurrent protection rated in accordance with the rating plate on the specific system.

The supply must be able to be isolated by means of a lockable switch or circuit breaker, which must be suitably located, easily reached and clearly marked as the TPPR disconnect device.

The wiring used between the isolator and TPPR must be appropriately rated and approved.

Ensure that the power supply is able to maintain sufficient voltage level for the connected field devices and to recharge the backup batteries.

External DC supplies would *normally* connect directly to the DC-UPS input terminals, but other connection methods may be used.

MODBUS INSTALLATION

5.1.4 DC Power Output

The TPPR DC power output can be set to between 24 and 28 VDC (the default is 24 V).

TPPR power supply units (PSU) include a DC Ok relay that closes when the output voltage reaches the adjusted output voltage level, and opens when the output voltage dips more than 10% below the adjusted output voltage level.

The DC Ok Relay has a maximum rating of 60 VDC 0.3 A, 30 VDC 1 A or 30 VAC 0.5 A resistive load and a minimum permissible load of 1 mA at 5 VDC.

Note: If the battery backup option is being used, ensure that the PSU DC output and the DC-UPS Module buffer voltages are set to >24 V to ensure optimum battery charging for 2 x 12 V batteries.

Note: If the Power Redundancy Module is being used, ensure that both PSUs have the same output voltage.

5.2 Cabling Requirements

All cabling should meet local, national and international regulations, and be suitable for the operating environment. Cable should be appropriately rated and approved. Bootlace ferrules should be used on all stranded cable end terminations unless otherwise stipulated (e.g. where the backup batteries use spade terminals).



WARNING

All cabling must be appropriately rated and approved in accordance with local, national and international regulations. Additionally, cabling must satisfy requirements defined in the technical manuals of connected field devices, especially when the field device is certified for use in hazardous locations. This is particularly important when reusing existing or legacy cables.

WARNING

In Canada and the USA, in both ordinary and hazardous locations, all electrical installations, including connections, cabling and overcurrent protection must strictly adhere to both the National Electrical Code (NEC) and the Canadian Electrical Code (CEC).



5.2.1 Device Cables

Field device cabling should be appropriate to the area classification, and in accordance with the device manufacturer's recommendations. Refer to local and national regulations where appropriate, and the field device manual. All sensor field cables must be shielded and grounded to ensure correct operation of the system and to meet European Standards for RFI and EMC.

Ensure that the maximum loop resistance is not exceeded, as specified by the device manufacturer.

Take account of voltage drops due to line resistance to ensure that the correct voltage level is present at the field device, as specified by the device manufacturer.

The I/O modules will accept wire sizes up to 2.5 mm² / AWG 11.

5.2.2 External Power Supply Cables

Use approved supply cables rated in accordance with the rating plate on the specific system, in accordance with local and national regulations. The TPPR power supplies will accept wire sizes in the range 0.5 – 6 mm² / AWG 25 – 3 (solid wire), 0.5 – 4 mm² / AWG 25 – 7 (stranded wire).

5.2.3 Bus Interface Cables

Modbus cables should use a good quality signal cable suitable for RS485 connections. See *Ch.6.5 Modbus Cables* for further information.

MODBUS INSTALLATION

5.2.4 Ethernet Cables

Ethernet cable must be CAT5e or CAT6 Ethernet cable terminated to TIA/EIA-568B standard. The cable should have shielded RJ45 plugs with the shield of the cable bonded to the metal body (shield) of the connector plug. The cable length should not exceed 100 m. The Ethernet cable should be fitted through a gland to preserve the IP rating where appropriate.

5.2.5 TPRR Battery Box Cables

Connect the TPRR Battery enclosure to protective earth using a minimum wire size of 6 mm² (10 AWG) and the M8 Protective Earth (ground) stud.

The cable between the TPRR System UPS and the TPRR Battery Box must be 4 mm² / AWG 7; UL/CSA approved wiring material, tri-rated (105 °C). The maximum cable length between the Battery Box and the UPS is 5 m. Bootlace ferrules must be used on all stranded cable end terminations except for the battery-end spade terminals (supplied).

5.2.6 24 VDC Power Cables

24 VDC power cables should be rated appropriate to the current load.

The Modules will accept a maximum wire size of 1.5 mm² / AWG 15 and the DIN rail connector will accept a maximum wire size of 6 mm² / AWG 3.

5.2.7 Ring Network Cables

Ring network wiring should use good quality signal cabling suitable for RS485 signals.

The external ring network cabling should be shielded and grounded twisted pair cables. The terminals will accept a maximum wire size of 1.5 mm² / AWG 15.

5.2.8 Ring Network Cable Restrictions

The TPRR total ring network cabling must not exceed 3 km (1.86 miles). The distance between individual TPRR units (i.e. between a Controller and a Remote Unit) must not exceed 1 km (0.62 miles).

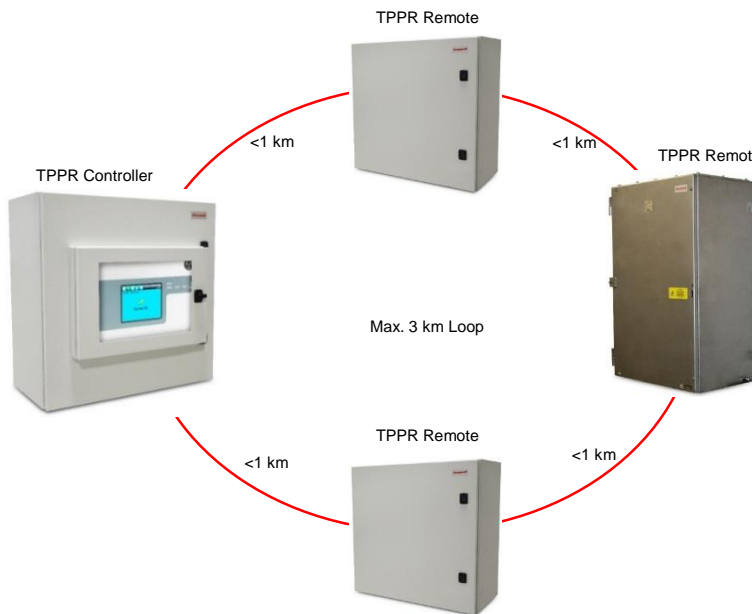

Figure 41. Ring Network Maximum Distances

MODBUS INSTALLATION

5.2.9 Earthing (Grounding)



WARNING

All TPPR equipment, sensors and cable shielding shall be earthed (grounded) using only the dedicated TPPR earth terminals or common earth rail. Do not disturb or remove factory-fitted earth connections.

All cable armour and/or metal conduits shall be separately earthed and isolated from the TPPR, its equipment and its attached cables.

Avoid creating earth (ground) loops.

5.2.10 Location of the Primary TPPR Protective Earth (Ground) Connection Stud

The primary TPPR protective earth (protective ground) stud is marked with a green earth (ground) label, and can be found:

- Standard enclosures – lower left corner
- Rack mount units – reverse side, lower left corner

Instrument and common earth (ground) points are marked with a black and white earth label.

5.2.11 Cable Shielding (Screening)

Field device cable shielding shall be connected to instrument earth (ground) at the respective TPPR controller or remote unit only, and the opposite end shall be isolated from contact with any metal body or cable.

Factory supplied enclosures contain a pre-fitted bus bar for earthing the field cables and it is recommended that OEMs fit them in their custom TPPR enclosures / racks.

The diagrams below show some examples of acceptable TPPR earthing and shielding practice.

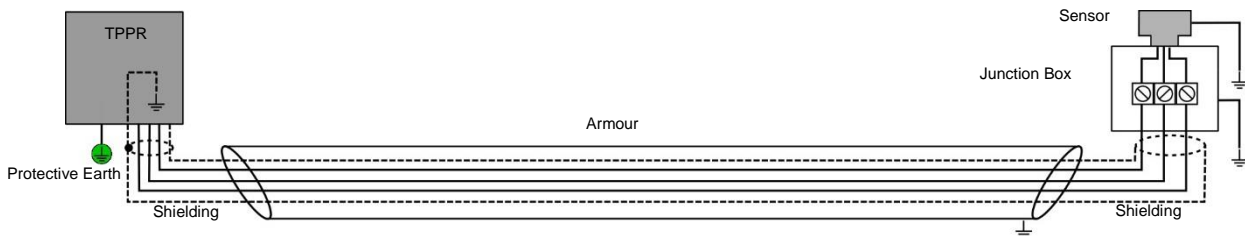

Figure 42. Shielding with Metal Armour, Metal Junction Box and Metal Sensor Body

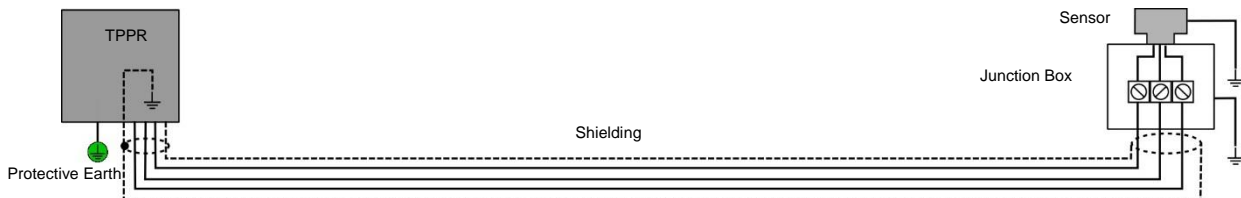

Figure 43. Shielding with no Armour, Metal Junction Box and Metal Sensor Body

MODBUS INSTALLATION

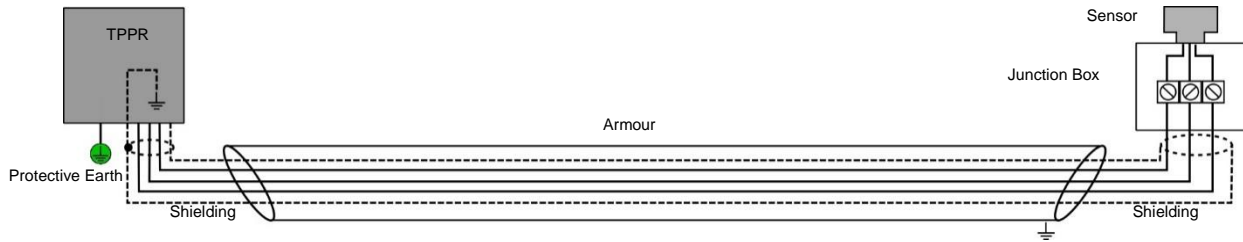

Figure 44. Shielding with Metal Armour, Plastic Junction Box and Plastic Sensor Body

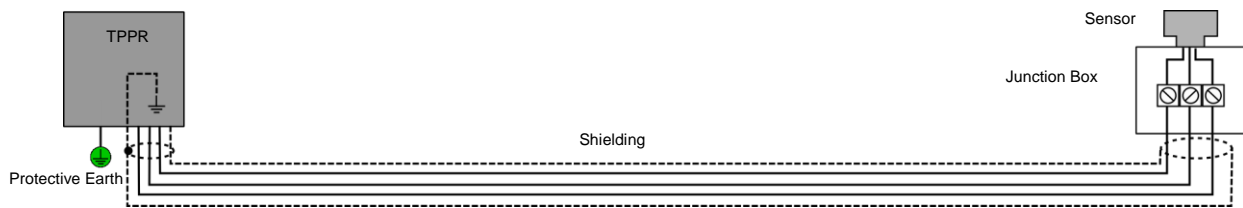

Figure 45. Shielding with no armour, Plastic Junction Box and Plastic Sensor Body

Note:

Cable shielding (screening) shall be connected to the TPPR enclosure’s common earth point only, and both shall be fully isolated from all other metal bodies.

Cable armour and/or steel conduit and/or metal junction boxes and/or metal sensor bodies must be connected to protective earth (ground) in the field and shall be kept fully isolated from contact with cable shielding (screening) and from contact with TPPR enclosures or metal enclosure glands.

Long cable runs should be earthed in the field at regular intervals but be careful to avoid earth (ground) loops.

MODBUS INSTALLATION

5.2.12 Assembling and Installing the Backup Batteries

Identify all required parts as follows:

- Two batteries – 12 Ah (small) or 27 Ah (large)
- One positive cable, one negative cable and one cable with bayonet style fuse holder
- Fitting kit of spade terminals, nuts, bolts and washers (used with 27 Ah batteries only)



CAUTION

Avoid shorting the battery terminals with metal or conductive objects, especially when connecting the cables or when installing the batteries in the enclosure.

It is advisable to remove the fuse before connecting the fused cable to the batteries, and to refit it only when all cables are correctly connected and tested.

For the large batteries only, fit a supplied spade terminal to each battery terminal using the supplied fixings. The correct sequence for the fixings is – bolt, flat washer, battery terminal, spade terminal, flat washer, spring washer, nut, as shown below.

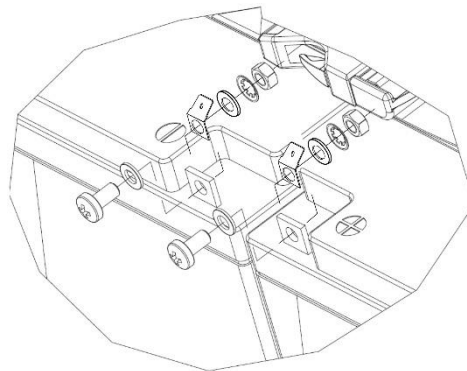

Figure 46. 27 Ah Battery Terminal Assembly

Note: Ensure that the terminals are positioned vertically and angled inwards or the cables will not fit.

The 12 Ah batteries fit into the offset mounting tray slots with the terminals to the front, while the 27 Ah batteries may require you to first remove the 12 Ah mounting tray (3 screws at the front and 2 at the back) before fitting the batteries with the terminals facing each other. Always fit the right hand battery first to avoid blocking access.

Normally the door opens to the left and the 27 Ah batteries are therefore positioned to the far right to avoid contact with the door hinge. However the door hinge can be changed to open to the right, in which case the 27 Ah batteries must be positioned to the far left instead.

1. Ensure that the Battery Isolator switch is correctly connected to the TPPR DC-UPS and is switched **Off** (Fig 48).
2. Ensure that the securing strap is open and held clear of the battery area.
3. Insert the first battery in the right-hand slot (12 Ah) or far right (27Ah).
4. Insert the second battery to the left of the first battery, observing the correct terminal orientation (see pictures below).

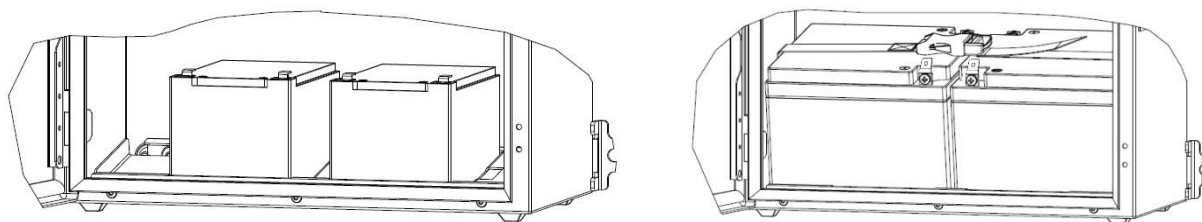

Figure 47. Correct Battery Orientation

MODBUS INSTALLATION

5. Fasten the securing strap over the batteries.
6. Optional; smear the battery terminals lightly with grease or petroleum jelly to prevent electrolytic corrosion.
7. Using the supplied cables, connect the batteries to the Battery Isolator switch (see picture below). Ensure that the protective boots cover the terminals.
8. Connect the supplied cable and fuse assembly between the two remaining battery terminals, red to positive, black to negative.
9. Check that the fuse is fitted and the bayonet holder is fully closed.
10. Switch the Battery Isolator **On** and ensure that the TPPR DC-UPS LED shows the correct battery status (requires TPPR to be connected to a power source and switched on).
11. Close and lock the access door and allow the batteries to recharge.
12. Check the DC-UPS periodically for battery status updates; carry out any necessary rectification or maintenance.

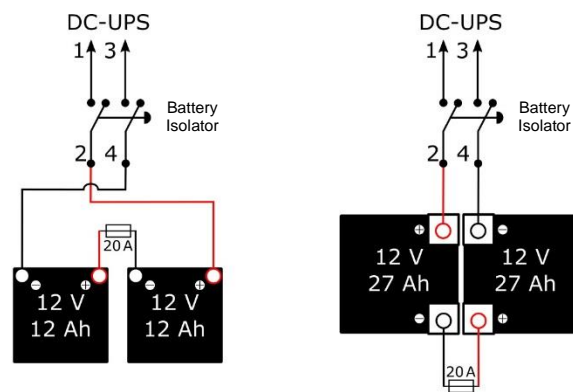

Figure 48. Battery Connections



WARNING

Unauthorised modification of the Touchpoint Pro system or components is forbidden as it will invalidate certification and may render the system dangerous or inoperable.

5.2.13 Connecting Devices to Modules

It is not necessary to populate all (or any) of the channels, nor in any particular order. In some cases you may have empty modules waiting for future system upgrades.

See the following sections for wiring and circuit plans and verify all connections before switching on TPPR power.

Note: The lower terminals (inputs 3 and 4) are inverted when compared to the top terminals (inputs 1 and 2) so it is not electrically possible to swap cable plugs from top to bottom or vice-versa.

MODBUS INSTALLATION

5.2.14 Connecting to an Analogue Input Module (4 – 20 mA)

The Analogue Input Module mA (AIM mA) is a sink module that accepts 4-20 mA source signals from 2-wire or 3-wire field devices. The sensors connect via the front-face terminals.

The module can supply 18-32 VDC (24 VDC nominal) to the field devices at a maximum current of 1 A per channel, with the additional limitation that the total current drawn from the module must not exceed 2 A at 65 °C ambient or 4 A at 55 °C ambient.

Voltage outputs are overload protected.

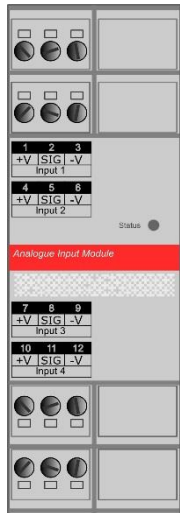

Channel	Terminal	Label	Field Device
Input 1	1	+V	24 VDC
	2	SIG	4 – 20 mA Signal
	3	-V	0 VDC
Input 2	4	+V	24 VDC
	5	SIG	4 – 20 mA Signal
	6	-V	0 VDC
Input 3	7	+V	24 VDC
	8	SIG	4 – 20 mA Signal
	9	-V	0 VDC
Input 4	10	+V	24 VDC
	11	SIG	4 – 20 mA Signal
	12	-V	0 VDC

Table 9. AIM mA Connection Table

The following diagrams show how to connect various types of device or sensor.

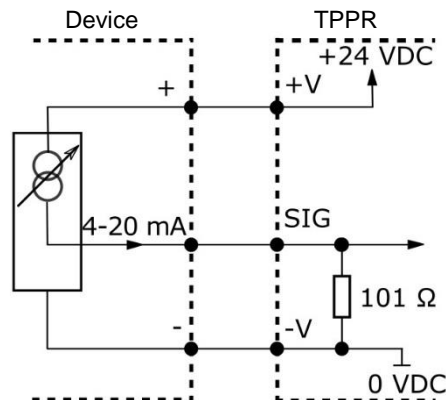

Figure 49. Three Wire Device

MODBUS INSTALLATION

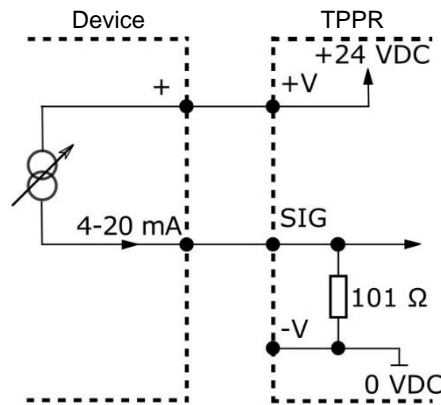

Figure 50. Two Wire Loop Powered Device

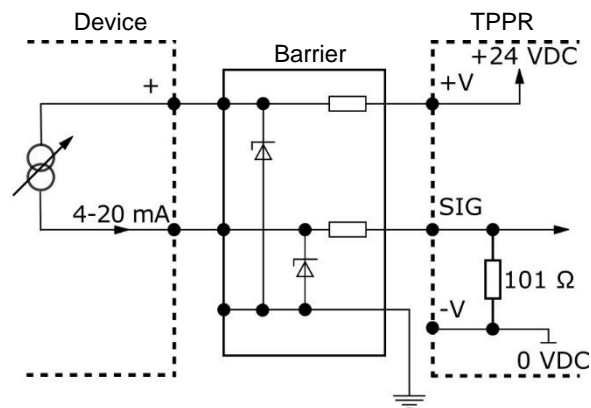

Figure 51. Two Wire Device with a Barrier

Note: Refer to the device manufacturer's instructions for details of approved barriers and connections for Intrinsically Safe (I.S.) field devices.

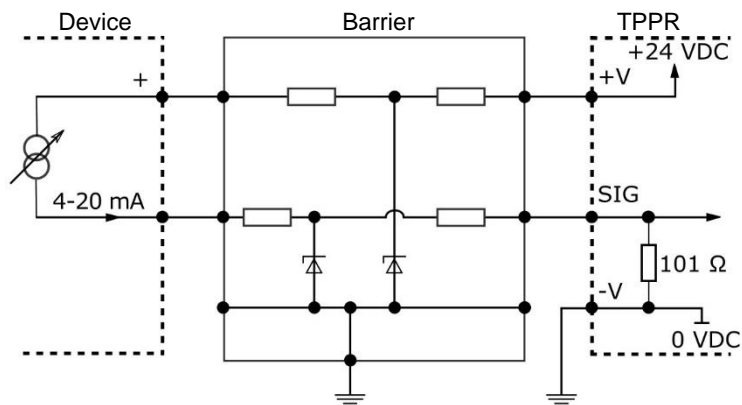

Figure 52. Two Wire Device with Alternative Barrier

MODBUS INSTALLATION

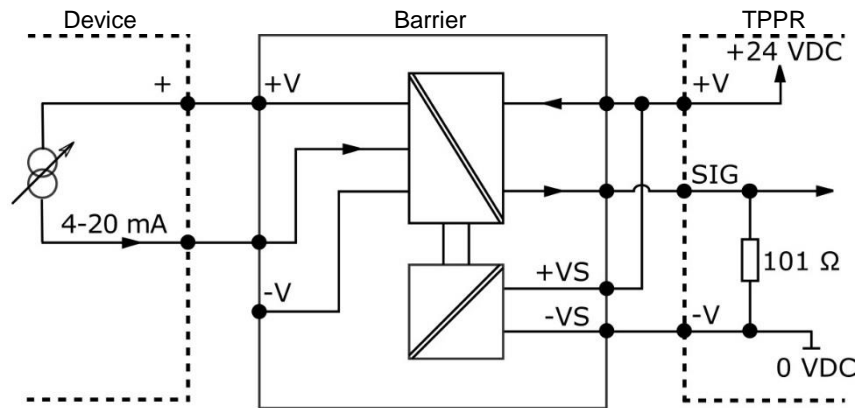
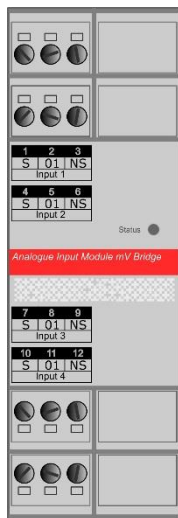

Figure 53. Two Wire Device with an Isolated Barrier

5.2.15 Connecting to an Analogue Input Module mV Bridge

The Analogue Input Module mV Bridge (AIM mV) accepts Catalytic (180 mA to 360 mA reactive bead) type sensors connected via the module's front-face terminals.

Bead current is programmable in the range 180mA to 360mA (default 200mA). Bead current may be independently set for each channel.



Channel	Terminal	Label	Field Device
Input 1	1	S	Sensitive (+)
	2	01	Signal
	3	NS	Non-sensitive (-)
Input 2	4	S	Sensitive (+)
	5	01	Signal
	6	NS	Non-sensitive (-)
Input 3	7	S	Sensitive (+)
	8	01	Signal
	9	NS	Non-sensitive (-)
Input 4	10	S	Sensitive (+)
	11	01	Signal
	12	NS	Non-sensitive (-)

Table 10. AIM mV Connection Table

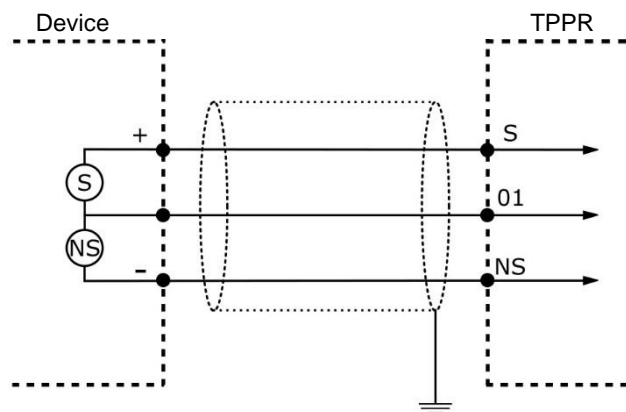

Figure 54. mV Bridge Catalytic Detector

MODBUS INSTALLATION

5.2.16 Connecting to a Digital Input Module

The Digital Input Module (DIM) has two modes of operation. A DIM channel may be configured to generate an alarm, fault or warning signal when activated.

Alternatively, a DIM channel may be configured to provide remote control of a selected group of one or more input / output channels. The DIM may be used to remotely reset, inhibit, or acknowledge the selected channels.

When used for inhibit, repeated activation toggles the inhibit state of the selected channels.

Note: It is the user's responsibility to guard against unauthorised inputs when using remote switches, buttons or keys.

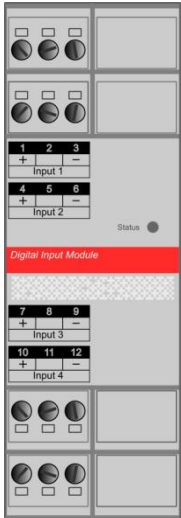

Channel	Terminal	Label
Input 1	1	+
	2	
	3	-
Input 2	4	+
	5	
Input 3	6	-
	7	+
Input 4	8	
	9	-
	10	+
	11	
	12	-

Table 11. IM Connection Table

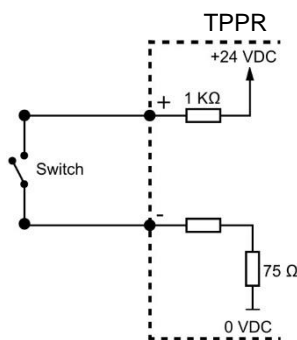

Figure 55. Unsupervised Circuit

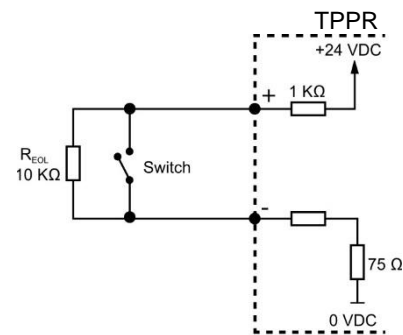

Figure 56. Supervised for Open Circuit

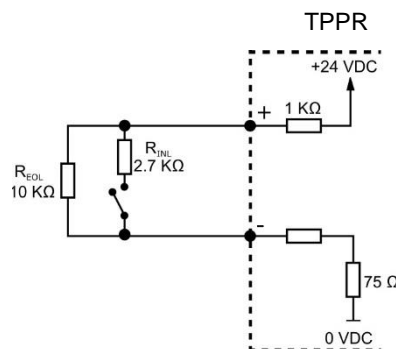

Figure 57. Supervised for Open and Short Circuit

MODBUS INSTALLATION

5.2.17 Connecting to a Relay Output Module

The Relay Output Module (ROM) provides relay outputs to switch field devices such as sounders, beacons and actuators. In addition, an auxiliary voltage supply is available to provide power to such devices.

The relay contacts have a recommended range of ≥ 12 VDC, 10 mA to 250 VAC / 30 VDC 5A. The maximum contact current rating is 5 A per channel, with the additional limitation that the maximum contact current rating for the module is 8 A. An overcurrent protection device should be fitted to prevent higher current flowing through the relay contacts.

The auxiliary voltage supply provides DC 24 V (18–32 VDC) to the field devices at 1.5 A max. per channel, with the additional limitation that the total current drawn from the module must not exceed 1.5 A. The supply is short circuit protected – if a short circuit is detected the supply to all four channels is disconnected to prevent damage. The auxiliary voltage supply will be restored automatically when the cause of the short circuit is removed.

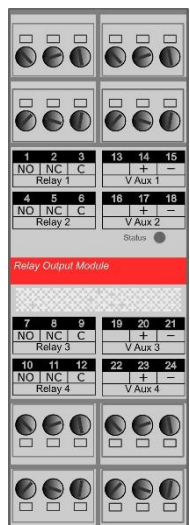

Channel	Terminal	Label	Channel	Terminal	Label
Relay 1	1	NO	V Aux 1	13	
	2	NC		14	+
	3	C		15	-
Relay 2	4	NO	V Aux 2	16	
	5	NC		17	+
	6	C		18	-
Relay 3	7	NO	V Aux 3	19	
	8	NC		20	+
	9	C		21	-
Relay 4	10	NO	V Aux 4	22	
	11	NC		23	+
	12	C		24	-

Table 12. ROM Connection Table (Unpowered)

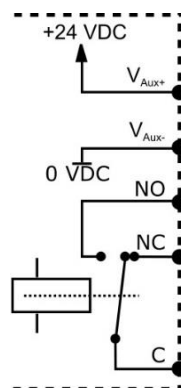

Figure 58. ROM Connections

MODBUS INSTALLATION

5.3 Controller Electrical Connections

Controller electrical connections are detailed on the Controller cover (shown below).

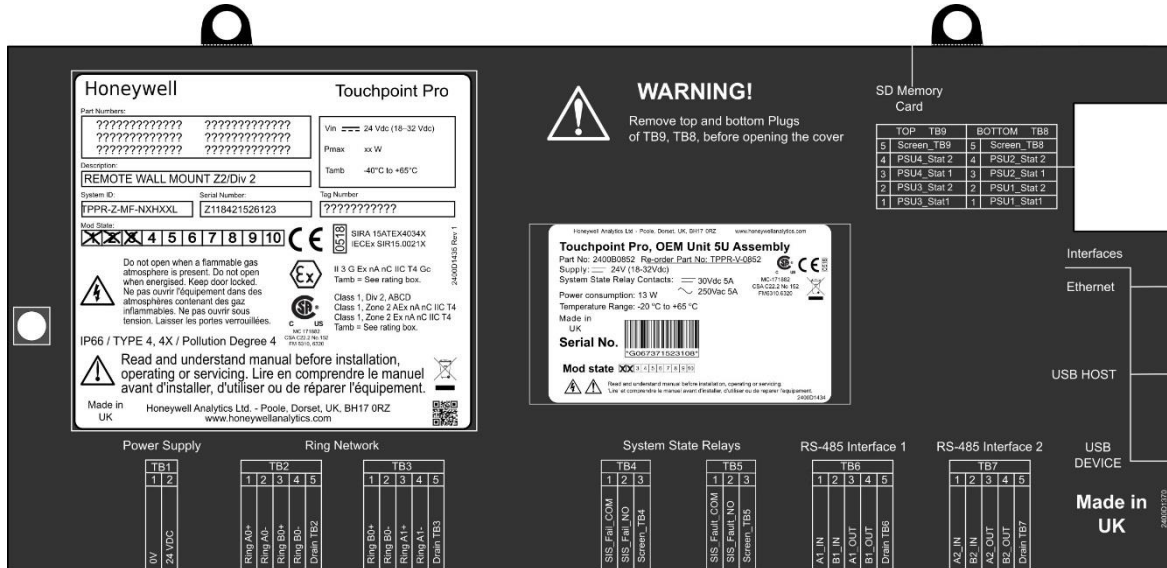

Figure 59. Controller's Terminal Layout Map

5.3.1 Communications Ring Wiring

The ring wiring connects from TB2 and TB3 on the controller to one or more Ring Coupling Modules (RCMs), depending on the system configuration. The RCMs may be fitted in the same cabinet as the controller, in a remote cabinet up to 1km away, or a combination.

5.3.1.1 Ring Coupling Module (RCM) Connections

Each backplane requires an RCM. The RCM is normally positioned in the leftmost position on the backplane.

Input	Terminal	Label	Channel
Input 1	1	+	Ring A In
	2	Drain	
	3	-	
Input 2	4	+	Ring B Out
	5	Drain	
Input 3	6	-	
	7	+	Ring B In
	8	Drain	
Input 4	9	-	
	10	+	Ring A Out
	11	Drain	
	12	-	

Table 13. RCM Connection Table

Note: Terminal 2 is connected to Terminal 5 and Terminal 8 is connected to Terminal 11. The Drain terminals are capacitively coupled to power supply 0V.

Refer also to section Ring Coupling Module (RCM) 21.4.3 for RCM specifications.

MODBUS INSTALLATION

The following diagrams show typical ring wiring. For clarity, screens are omitted.

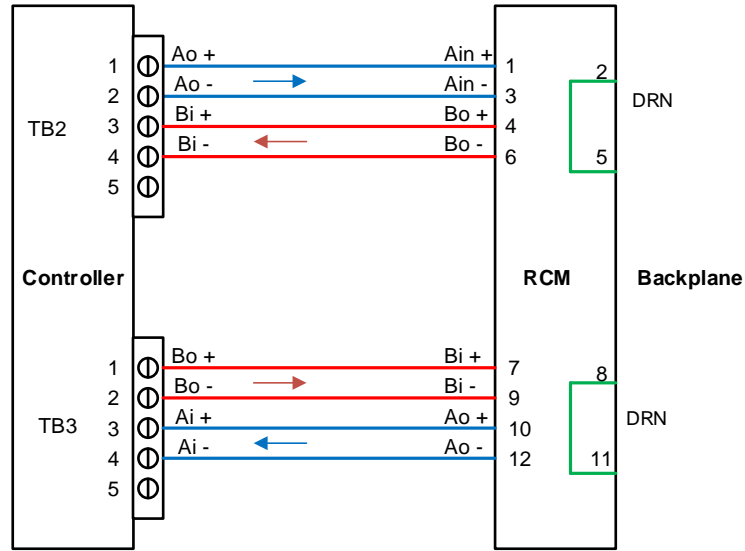

Figure 60. Ring Network Connections

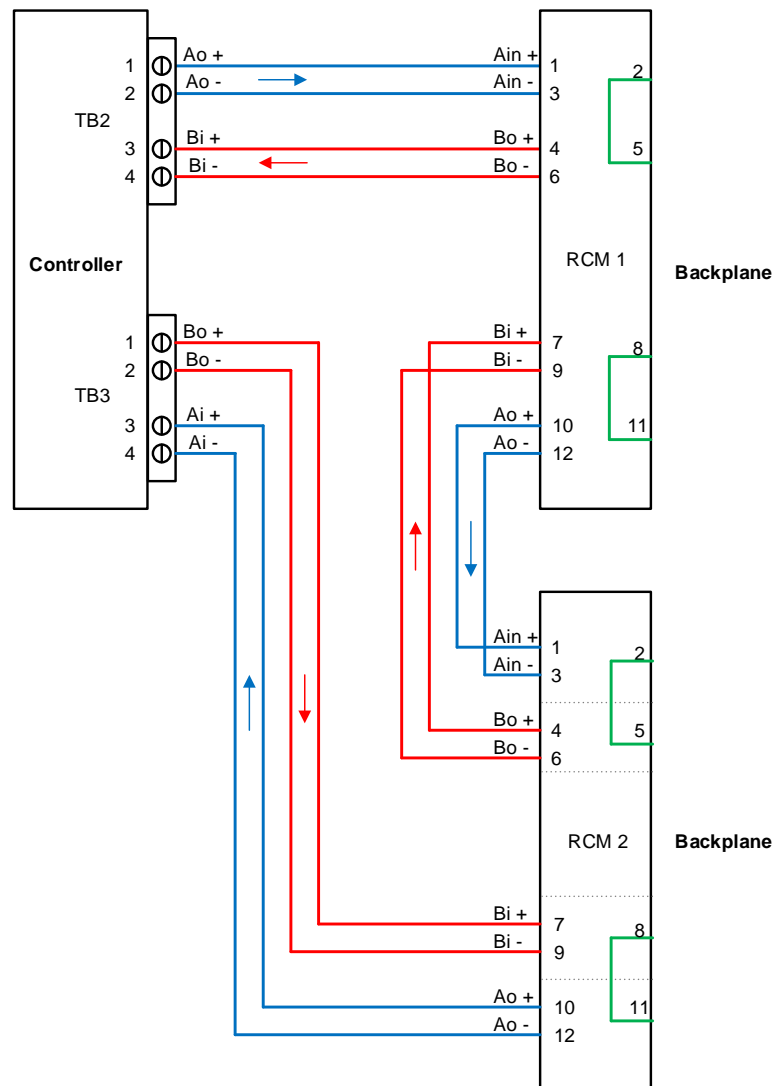

Figure 61. Ring Network - Dual Backplane

MODBUS INSTALLATION

5.3.1.2 Screen Connections

It is the installer’s responsibility to provide suitable connections for ring cable screens.

The Drain (DRN) connections at the controller and at the RCM should be connected. They are capacitively coupled to the controller/backplane 24V return (0V) line, and isolated to DC.

Connections to earth or chassis must be made externally.

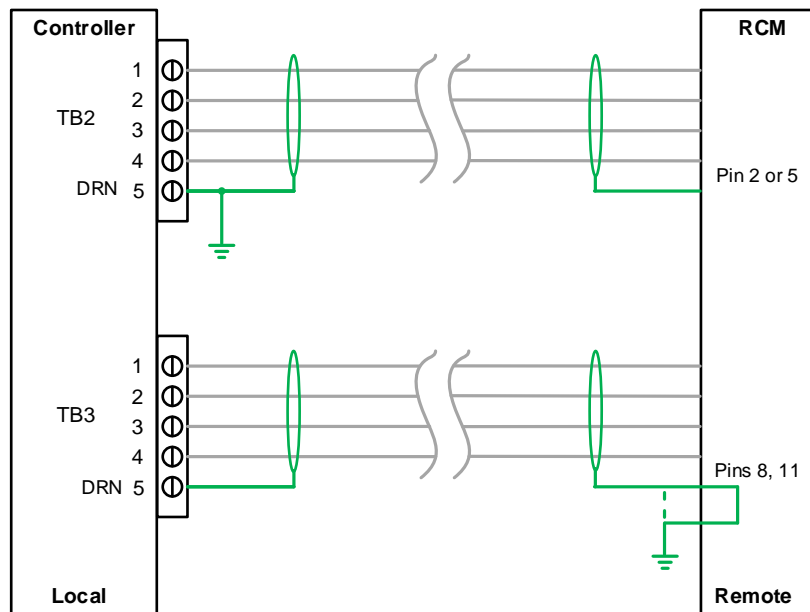

Figure 62. Representative Screen Connections

5.3.1.3 Earth Clamp

The ring cable screen should be connected to chassis using a suitable clamp. To avoid ground loops, each screen should only be grounded at one end.

5.3.1.4 Multiple RCMs

Screens between multiple RCMs may be connected using the RCM DRN connections on pin 2/5 and 8/11. Each leg should be provided with a separate single earth connection.

5.3.1.5 Communications Ring Cabling

The communications ring uses RS485 signalling.

The external ring network cabling should use 2x2 twisted pair cables with overall screen. The cable used should take into account the location, environment and distance but must be a good quality signal cable suitable for RS485 signals and meeting the following requirements:

Requirement		Value
Cable size	Minimum	1mm ²
Loop Resistance	Maximum	26 ohms/km
Mutual capacitance conductor to conductor	Maximum	125 pF/m
Mutual capacitance conductor to shield	Maximum	160 pF/m
Inductance conductor to shield	Maximum	0.65 mH/km

Table 14. Communications Ring Cable

For ease of wiring and commissioning, different wiring colours should be used for A and B rings. The terminals will accept a maximum wire size of 1.5 mm² / AWG 15.

MODBUS INSTALLATION

5.3.2 TPRR Controller' System State Relays

The System State Relay connections are located on the Controller at TB4 and TB5 (See Figure 56). They are rated at 30 VDC (3 Amp) or 250 VAC (3 Amp).



CAUTION

An overcurrent protection device should be used if the System State Relays are being used to switch AC voltages.

5.3.3 Power Supply Unit (PSU) Status Inputs

System Failure Relay (TB4)	Terminal	System Fault Relay (TB5)	Terminal
SIS_Fail_COM	1	SIS_Fault_COM	1
SIS_Fail_NO	2	SIS_Fault_NO	2
Screen_TB4	3	Screen_TB5	3

Table 15. System State Relay Connections

The Power Supply Unit (PSU) Status Input connections are located on the Controller at TB8 and TB9 (see Figure 59).

Four digital inputs are provided on TB8 and TB9. The inputs are provided for PSU status monitoring or ventilation monitoring. Refer to section 13.16 for further information.

They may be used as general purpose digital inputs if not required for this specialist monitoring.

These inputs can be configured to act as Global Acknowledge, Global Reset or Global Inhibit.

Digital Input TB8	Terminal	Digital Input TB9	Terminal
PSU1_Stat 1	1	PSU3_Stat 1	6
PSU1_Stat 2	2	PSU3_Stat 2	7
PSU2_Stat 1	3	PSU4_Stat 1	8
PSU2_Stat 2	4	PSU4_Stat 2	9
Screen_TB8	5	Screen_TB9	10

Table 16. PSU Input Connections

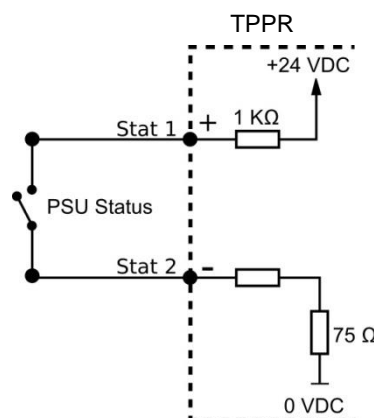

Figure 63. PSU Status Circuit

5.3.4 RS485 (Modbus) Interface 1 & 2 Connections

See *Ch.6 Modbus Installation* for details on installing and connecting to the optional Modbus PCB.

The RS485 Interface functions on TB6 and TB7 are described in the Modbus section. Refer to Chapter 11

MODBUS INSTALLATION

5.4 First Time Switch On

Before applying power to TPPR, ensure that all wiring and connections are correct and that all glands are tightened.

Switch on the battery isolator switch (if DC-UPS is fitted) and then the main isolator switch.

During the start-up, verify that the front panel LEDs illuminate in sequence and that the buzzer sounds. Verify that the LCD functions correctly.

During TPPR start-up check that the DC supply voltage is between 18 and 32 VDC at the Vaux terminals of a Relay Output Module (preferably furthest from the power source) or at the V+ and V- terminals of an Analogue Input Module.

TPPR initialisation typically lasts for 3 – 10 minutes depending on the number of channels and sensors in the system.

TPPR will then display the System Status screen, indicating the current status of the system.

Note: AIM-mV Bridge channels will be in **Inhibit** mode until calibrated. In addition, some mA or mV channels may have a 'power-up' delay programmed, which means that those channels could remain inhibited until the end of the delay, i.e. up to 5-mins.

The TPPR Controller System Status Screen is shown below.

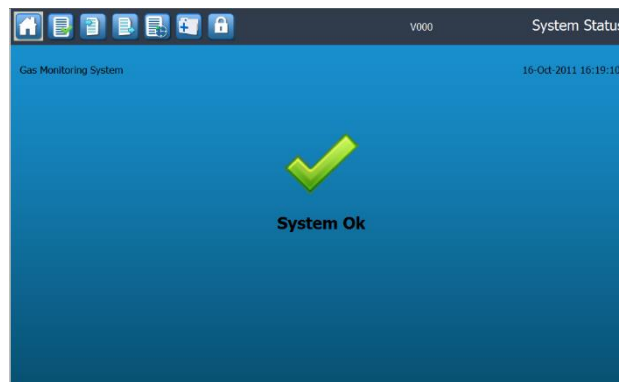

Figure 64. System Status Screen

MODBUS INSTALLATION

6 Modbus Installation (Option)

6.1 Introduction

The optional TPPR Modbus Interface provides a facility for digital communication between the TPPR and an external computer system. Modbus is a well-supported digital data communication protocol that provides a standardised set of data communication protocols.

The principal features of the Modbus Interface are:

- Operates as a Modbus Remote Terminal Unit (RTU) slave device node.
- Supports functions 02, 03, 04, 06 and 16 of the Modbus protocol.
- Provides sensor gas readings and alarm status for Fault, Inhibit, Warning, A1, A2, A3, STEL, LTEL and Rate alarms from all input channels in the system.
- Supports commands to Inhibit, Reset and Acknowledge for all channels in the system, as well as Global Reset and Global Acknowledge.
- Dual RS485 half-duplex communication with multi-drop capability.
- Asynchronous serial link configurable for baud rate and parity.

Maintenance Note: The Modbus broadcast commands are not supported and will be ignored.

6.2 Programming the Host

The host computer system must be programmed to interpret the signal and status data from TPPR as there is no defined standard Modbus format for the communication of data from gas detection systems.

It is recommended that the host computer system should, as a minimum, be programmed to use Function 02 to collect alarm and status data from all TPPR channels.

Full details of the Modbus protocol can be found in the Modicon Modbus Protocol Reference Guide PI-MBUS-300 available from www.modbus.org.



CAUTION

Some transceiver manufacturers incorrectly use RS-485 pin A as data positive and pin B as data negative. You may have to swap over TDA and TDB (A in and B in) if your Modbus does not work as expected.

6.3 Addressing Conventions and Register Values

The addressing conventions and register values used follow those set by Modicon. The first digit of the on-board memory address refers to the data type stored in the register and therefore defines the Modbus function command that should be used when polling it.

1xxx – The Input Status Register addresses record the individual channels' status. They are read using Modbus Function 02.

3xxx – The Input Register addresses record the current input values of the individual channels. They are read using Modbus Function 04.

4xxx – The Holding Register addresses have two purposes. One range of addresses is used to send commands and receive the results of those commands. The other address range is used to send queries and store the results of those queries. They can be written singly using Modbus Function 06, written as a block using Modbus Function 16 and read using Modbus Function 03.

MODBUS INSTALLATION

6.4 Modbus Bus Interface Board (BIB) Installation

The optional Modbus Bus Interface Board (BIB) is required to use Modbus communications. Normally the BIB is factory installed, but it can be fitted or replaced in the field by an authorised Honeywell Field Engineer.

TPPR is supplied with Modbus software pre-installed.

6.4.1 How to Install the Bus Interface Board



WARNING

The equipment specified in this manual is only to be installed by the Manufacturer's trained personnel, or by competent persons trained in accordance with the Manufacturer's installation instructions.



WARNING

There is a risk of electric shock when carrying out this procedure. Ensure that the system and backup batteries are electrically isolated and that residual power is allowed to dissipate before opening the enclosure.



WARNING

If the TPPR relays are switching mains voltages, hazardous live terminals may be present within the Relay Output Modules even if the TPPR is electrically isolated.



WARNING

Site Safety systems will be inoperative during this procedure. Ensure that a risk assessment is carried out and that alternative safety arrangements are in place before commencing.



CAUTION – ELECTROSTATIC HAZARDS

All electronic and PCB assemblies contain static sensitive components. Take anti-static precautions to minimise the risk of damaging components through electrostatic discharge.



CAUTION

The SD Card, any USB device and all cables must be removed before attempting to remove the Control Module cover panel.

To fit the Bus Interface Board:

1. Power off and isolate the mains supply and backup batteries and any mains-switching relays.
2. Open the Controller enclosure to access the controller cover panel (see figure on next page).
3. Remove any USB devices and SD Cards.
4. See Warning at the top of the cover and disconnect all conflicting cables (i.e. TB8 & TB9).
5. Remove the two M4 locknut screws at the top and one at the side of the cover.
6. Carefully slide the cover off.
7. Locate the four Bus Interface Board (BIB) stand-off pillars to the right side of the Control Module motherboard).
8. Observing the correct orientation, align the connectors and gently push them into place.
9. Secure the Bus Interface Board using the supplied screws and washers.
10. Carefully slide the cover back into place and refit / tighten the M4 locknuts.
11. Re-connect all cables.
12. Refit the SD Card and optional USB devices.
13. Switch on the batteries and Mains power.
14. Wait for the system to initialize and check/test that everything is working correctly.

MODBUS INSTALLATION

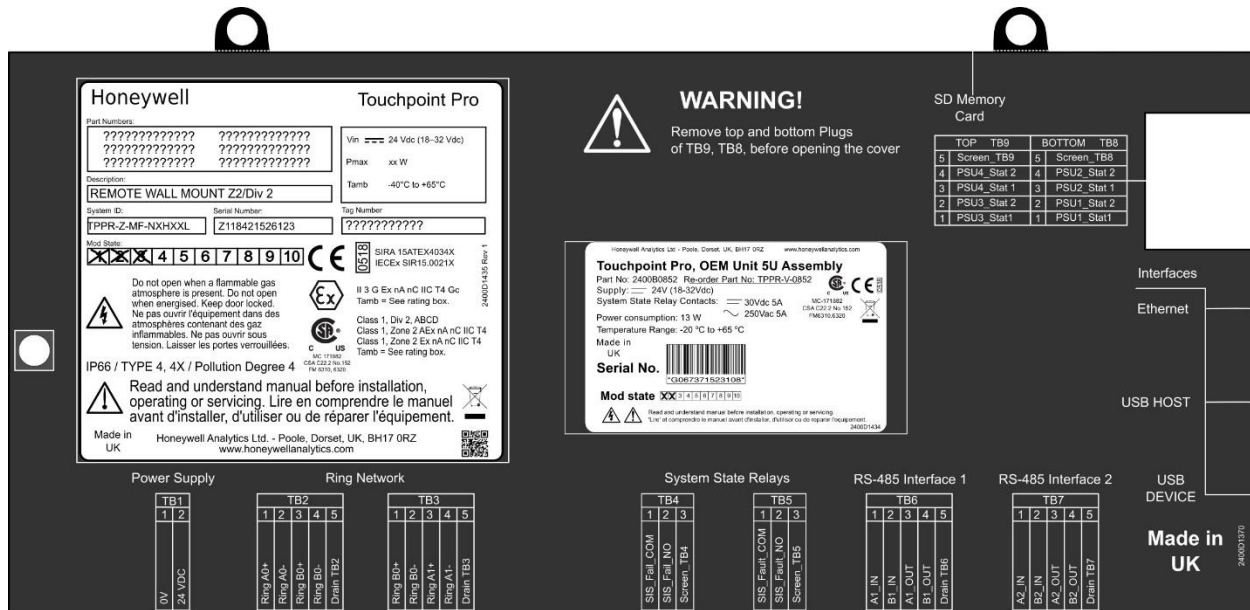

Figure 65. Controller Cover Panel

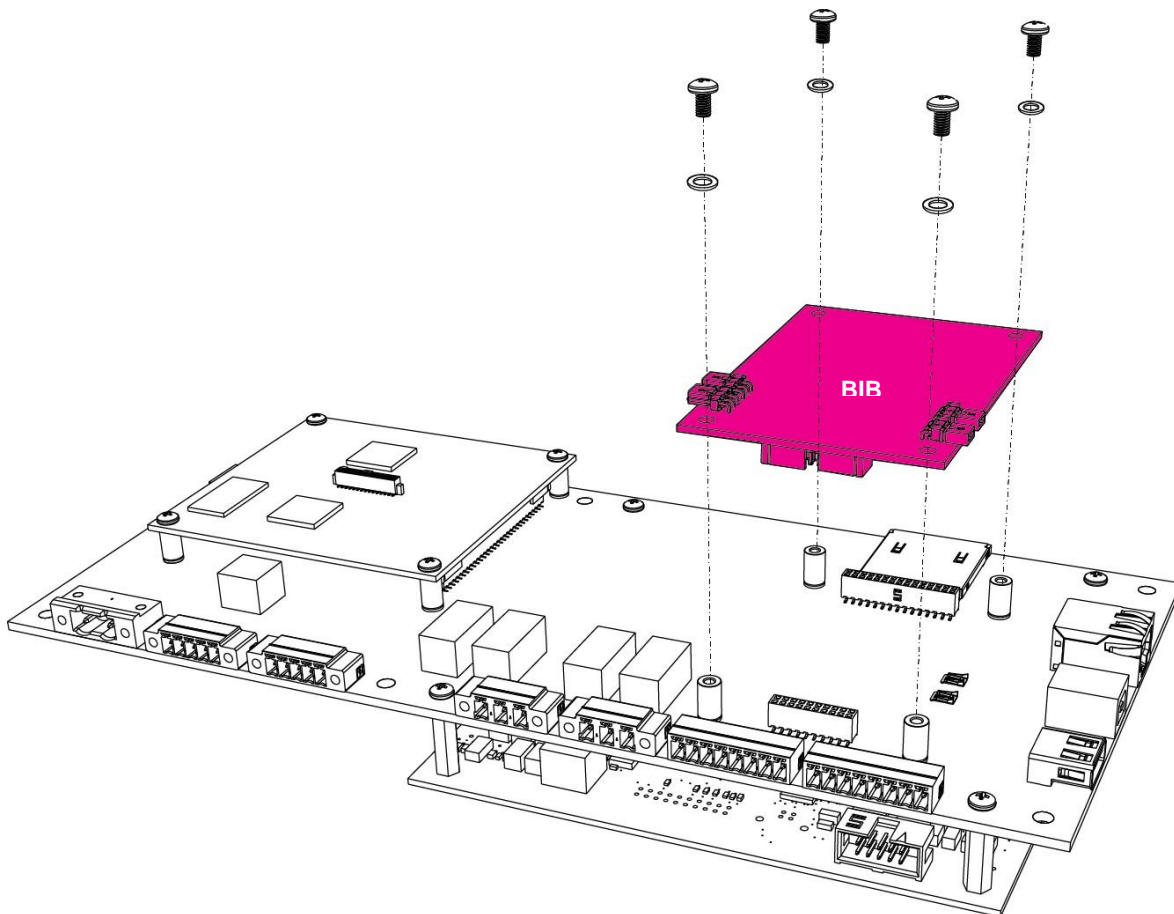

Figure 66. Bus Interface Board (BIB) Fitting

MODBUS INSTALLATION

6.5 Modbus Cables

The cable should be RS485 shielded data communication cable suited to the installation distance, ambient and environmental factors.

Note:

- Spurs shall not be longer than 1m each, and shall not exceed 10m combined total.
- The maximum cable length without line repeaters is 1.2km (3900ft).
- The maximum wire size is 1.5mm² (15 AWG).

6.6 Modbus Electrical Connections

The electrical connections are shown below:

Modbus RTU Interface		
Terminal	TB6	TB7
1	A1 IN	A2 IN
2	B1 IN	B2 IN
3	A1 OUT	A2 OUT
4	B1 OUT	B2 OUT
5	Drain TB6	Drain TB7

Figure 67. Modbus RTU Interface Terminals

6.7 Modbus RTU Connections

Note: The respective IN and OUT terminals are connected together internally, i.e. A1 IN is connected to A1 OUT.

6.8 Modbus Termination Resistor

If TPPR is the last node in a Modbus system highway you must connect the provided 120 Ω termination resistor between A and B, to avoid reflections on the RS485 circuit.

For convenience, TPPR has a set of jumpers that can be used to switch a 120 Ω resistor across the connection. In this case, the RS485 IN and OUT terminals are no longer connected together internally, and the OUT terminals are floating. Only the IN terminals should be used.

Note: The default jumper configuration is 0 Ω resistance.

MODBUS INSTALLATION

6.9 Modbus Configuration Examples

The Modbus interface consists of two independent Modbus ports. The RS485 connections are located on terminals TB6 and TB7 of the Control Module. For convenience, IN and OUT terminals are provided which are connected together internally.

The diagrams on the next page show example configurations of which the second and third offer redundancy.

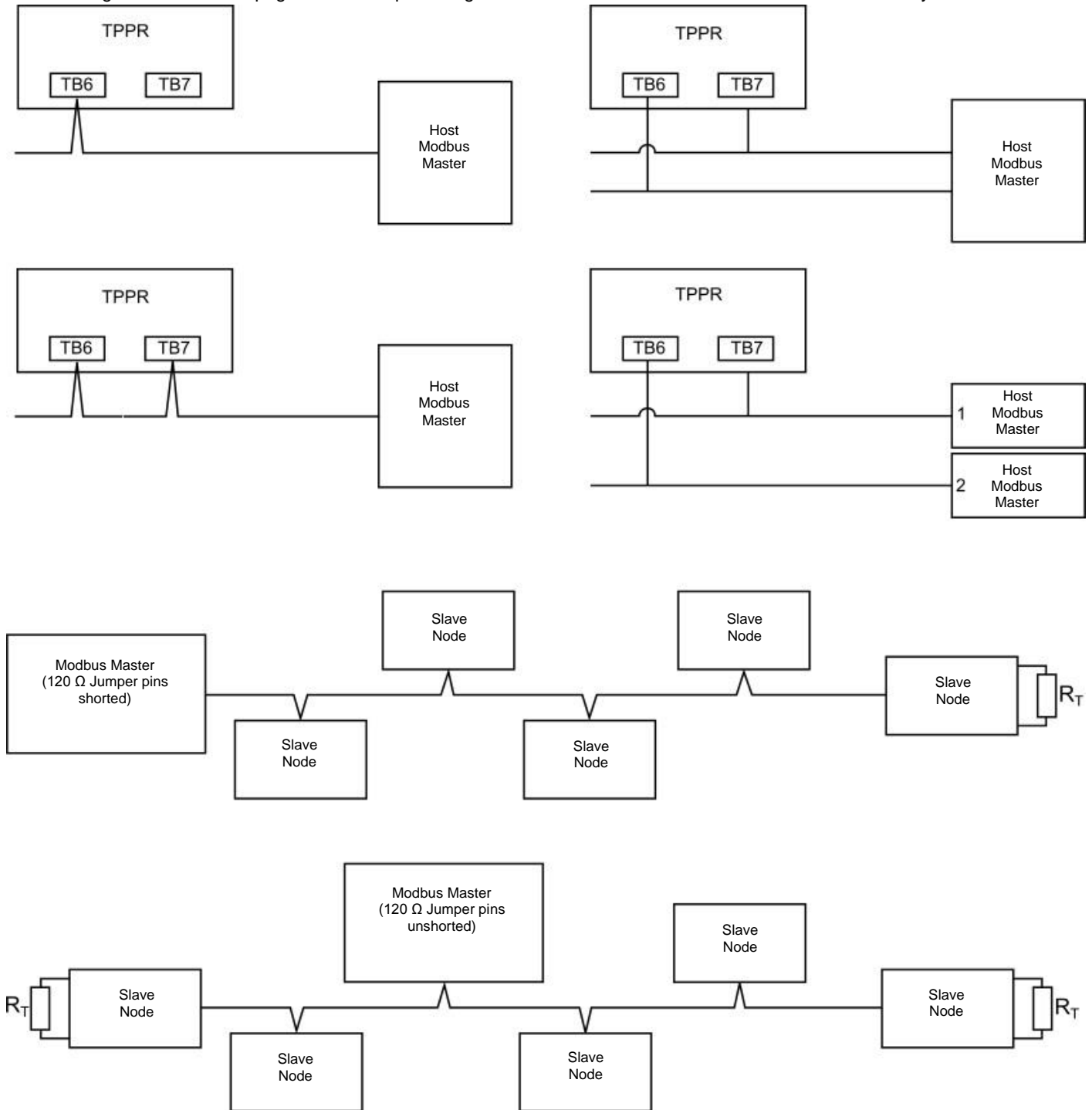

Figure 68. Six Modbus Configuration Options

Note: TPPR can fill any of the slave nodes but cannot have same slave IDs in daisy chain or multi-drop configuration.

Note: if a different resistance is required, leave the Modbus Master 120 Ω Jumper pins un-shorted and connect the resistor directly between TB6 and / or TB7 terminals 3 and 4 (A OUT and B OUT).

MODBUS INSTALLATION

6.10 Modbus Jumper Settings and Termination Resistor Fitting



CAUTION – ELECTROSTATIC HAZARDS

All electronic and PCB assemblies contain static sensitive components. Take anti-static precautions to minimise the risk of damaging components through electrostatic discharge.



CAUTION

The SD Card, any USB device and all conflicting cables must be removed before attempting to remove the Control Module cover panel.

To connect or change the termination resistor using the TPRR jumpers located on the Bus Interface Board:

1. Power off and isolate the mains supply and backup batteries.
2. Open the Controller enclosure to access the controller cover panel (see figure on next page).
3. Remove any USB devices and SD Cards.
4. Disconnect all conflicting cables.
5. Remove the two M4 locknut screws at the top and one at the bottom of the cover.
6. Carefully slide the cover off.
7. Locate the Bus Interface Board (BIB) on the right side of the Control Module motherboard).
8. Set the jumpers for the appropriate channel to the 'Termination On' position according to the diagram and table below.
9. Carefully slide the cover back into place and refit / tighten the M4 locknuts.
10. Re-connect all cables.
11. Refit the SD Card and optional USB devices.
12. Switch on the batteries and Mains power.
13. Wait for the system to initialize and check/test that everything is working correctly.

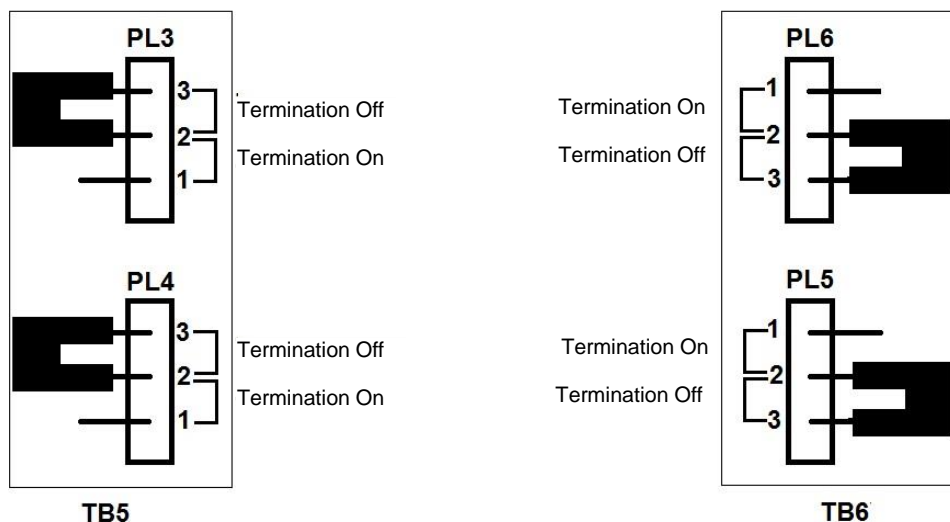

Figure 69. Modbus BIB Jumper Default Settings

Note: Jumper pins 1 & 2 are 'Resistance ON' and pins 2 & 3 are 'Resistance OFF'

6.11 Modbus Multi-Drop Mode

A maximum of 32 nodes (31 slave nodes plus one master node) can be supported for a multi-drop installation.

SETUP and COMMISSIONING

7 Software Setup and Commissioning

Once the system is fully initialised, **Administrators** and **Engineers** can calibrate the Touchscreen (if required) and they should confirm the **Panel Configuration** settings as follows:

- Selectable Backlight Duration:
 - 10 Seconds
 - 0.5 to 60 minutes in logical increments
 - Always On
- System Purpose Label
- Customer Name
- Customer Site
- Hardware Version
- Print Active Events (Enabled / Disabled)

7.1 How to Setup or Change the Touchscreen Panel Configuration:

1. Login as an **Administrator** or **Engineer**.
2. From the **System Status** screen select the **Tool Box** icon then **Global Settings**.
3. Select **Panel Configuration**:



Figure 70. Panel Configuration Screen

4. Click on a button to change its setting. Most are self-explanatory, but the **Calibrate Touch Panel** and **Print Active Events** options are described below.

7.2 How to Calibrate the Touchscreen

Recalibrate the Touchscreen if it does not respond correctly when touched. This process should take less than a minute but can only be performed at the Touchscreen.

Calibration must be fully completed once started as there is no option to abort the process.

To recalibrate the Touchscreen:

1. Login as **Engineer** or Admin
2. Select **Tool Box>Global Settings>Panel Configuration>Calibrate Touch Panel**
3. Follow the instructions, using a finger or soft stylus to touch each panel corner in turn
4. Finally touch the panel centre to exit

Note: The Fault LED may show if calibration is started but not completed, but will stop when calibration is fully completed.

Note: Screen calibration does not time out even when the backlight or UI times out, and user commands will not be available until calibration is fully completed. You must complete the Touchscreen calibration first, and then you can carry on with other activities.

SETUP and COMMISSIONING

7.3 How to Edit Service Contact Settings

To edit the **Service Contact Settings**:

1. Login as an **Administrator** or **Engineer**
2. From the **System Status** screen select the **Tool Box** icon then **Global Settings**
3. Select **Service Contact Settings**
4. Enter your local service contact details

7.4 Configuring the Touchpoint Pro TCP/IP Address and Printer

Each Touchpoint Pro Controller must be allocated its own unique static TCP/IP on your network and, for security reasons, this should never be the manufacturer's default IP address.



WARNING

Touchpoint Pro requires a **secure physical network connection** prior to the user being able to edit or save the TCP/IP configuration. If the controller is configured with a duplicate IP address (i.e. of other users already logged onto the network), you will not be able to save its TCP/IP settings until the duplicate address is resolved.



WARNING

TPPR must be protected against cyber-threats. Always consult the site IT department or a professional IT consultant before connecting TPPR to Computer Networks. Refer to the **Touchpoint Pro Security Guide**.

7.4.1 How to Configure the TPPR's TCP/IP Address

If the TPPR TCP/IP address is not already configured, or still has the manufacturer's default address:

1. Obtain a secure static IP address (typically from your site IT department). You will also need the default gateway address and subnet mask.
2. Using the TPPR Touchscreen, log in as an **Administrator** and then select: `Tool Box>Password>Global Settings>TCP/IP Settings`.
3. Select **Edit** and enter the TPPR's new IP address.
4. Check and edit the subnet mask to the one used on your local area network.
5. Check and edit the IP address of the network gateway if required.
6. Save the settings.

The TPPR checks that it has a working network connection, and checks that the programmed IP address is unique before it saves the new address settings.



CAUTION

A potential conflict could occur if another network device has the same IP address but is not currently connected. This can happen when rarely used items are switched on or connected to the network.

7.4.2 How to Configure the Printer

TPPR can print to a networked printer. To enable printing, enter the IP address of the required printer.

SETUP and COMMISSIONING

7.5 Enabling TPPR's Remote Connection Port

The Remote Connection port is a software port that shares the TPPR Ethernet connection. It is used by the:

- PC Configuration software
- Webserver Certification Tool (WSCT)

As a security measure, TPPR will only allow a maximum of 2 hours connection to the Remote Connection port in a single session. The user is automatically disconnected after two hours.

To use the remote software, enable the port, as described below, and then connect and log in using the remote software. Users may log in and out as required while the port is enabled.

Note: The port can only be enabled from the controller touchscreen.

See the *PC Configuration Operating Manual* for further details.

7.5.1 End of session warning

Logged in users will get a warning message 10 minutes before the connection is terminated, which will give them the option of saving, confirming or discarding their edits before the connection is terminated.

Users who log in after the final 10 minutes will be told how long they have left before the connection is automatically closed.

If a configuration session is still active when the port is closed, unsaved edits will be lost and the module being edited may remain in Configuration mode with channels inhibited. It may be necessary to log in to the System Configuration screen and set the module back to Normal mode.

7.5.2 Additional Time

If additional time is required, the port may be immediately enabled again for a further 2 hours.

7.5.3 Enabling the Port

To enable the port, log in from the controller and navigate to the **TCP/IP Settings** screen as described in section 7.4. From the tools menu, select **Enable 2 hrs**.

7.5.4 Disabling the Port

To disable the port, log in from the controller and navigate to the **TCP/IP Settings** screen as described above. From the tools menu, select **Disable**.

The Remote Connection port is automatically disabled when the remote user session is disconnected, either manually or following an inactivity timeout, or when the 2 hour session expires.

7.5.5 Webserver and Printer

The Webserver and printer use the same Ethernet connection but do not require the Remote Connection port to be enabled.

7.6 How to Print Active Events

Events recorded to the system Event Log can be sent concurrently to a networked printer as hard copy. All events are then sent to the printer.

Note: To enable printing, ensure the printer is connected to the Ethernet port and a valid TCP/IP address is being used. Refer to section 7.4.2.

To change print settings:

1. Login as an **Administrator** or **Engineer**
2. From the **System Status** screen select the **Tool Box** icon then **Panel Configuration**
3. Select **Print Active Events**
4. Select **Enabled** or **Disabled** and then **Apply**

When enabled, each event will be sent to the printer as it occurs.

CALIBRATING GAS SENSORS

8 Calibrating Gas Sensors

All gas sensors must be calibrated on commissioning, on replacement, at regular intervals specified in their user manuals, or when dictated by usage. (Touchpoint Pro can be programmed to generate periodic calibration reminders. See *Ch. 9.2.16 & 9.3.16* for information on *Calibration Reminder Settings* for AIM-mA and AIM-mV settings respectively.)

Note: Calibration data is not retained following a restore operation and calibration reminders may require updating following recalibration.

The basic calibration procedure is to first clear the sensor of any target gas and then introduce a known concentration of a test gas followed by a rest period to ensure that the sensor goes back to normal.

Note: Oxygen (O₂) calibration is done at the sensor while Carbon Monoxide (CO) calibration should follow the user's local procedures.



CAUTION

Ensure that executive actions/outputs are inhibited and alternative safety arrangements are made before starting any TPPR testing or calibration.



CAUTION

It is expected that mA sensors will be calibrated at the sensor or field device. The TPPR mA calibration is not intended to calibrate the sensor, but to align the TPPR 4-20mA current loop with the sensor current loop zero and span settings.

The TPPR mA calibration should not be used to calibrate the sensor zero and span, or to compensate for deficiencies in the sensor or transmitter calibration. Failure to observe this can result in significant accuracy errors.

8.1.1 Calibration Definitions

- **Clean Air** describes ambient air that has a nominal zero concentration of the target gas being sensed.
- **First Span** is the name given to the first gas span reading of a new mV sensor, which is used to monitor the sensor's sensitivity over time.
- **Over Range Warning** is when a mV sensor exceeds 100 % of Full Scale Deflection (100 %FSD). A gas over range condition can cause catalytic sensors to operate outside of their working range and incorrectly indicate low gas concentrations when hazardous concentrations may be present.
- **Span gas** is a compressed gas containing a specified concentration of the target gas being sensed.
- **Span** is the gas concentration reading at which calibration is carried out, typically at 50% of full scale.
- **Zero Gas** describes a test gas that has a zero concentration of the target gas being sensed, and it may be a different gas for different sensors.



DANGER

An '**Over Range Warning**' may indicate a rare but potentially catastrophic event that must be fully investigated. When **Over Range Warning** is programmed, TPPR displays a warning on the Touchscreen that requires an additional Reset operation before the alarm may be cleared.

CALIBRATING GAS SENSORS

8.2 Calibrating AIM-mV Input Channels

Touchpoint Pro supports routine calibration of mV sensors. TPPR can be programmed to display calibration reminders at calibration intervals, e.g. annually or every six months.

It is compulsory to calibrate the sensor when a channel has been newly commissioned, when the sensor bead current has been changed, or if the system configuration has been deleted.

TPPR warns when the output from a sensor reaches 50% of its initial value and should be replaced. The **First Span calibration option** is used to record the initial output level of a new sensor.

Note: The maximum allowable span signal is 300mV for 100% FSD. This figure is scaled by the Span Gas Concentration that has been entered i.e. 50% span gas concentration limits the maximum mV reading to 150mV.

Note: TPPR mV Analogue Input channels (AIM-mV) will remain in the **Inhibit** state until they are calibrated.

Note: Zero and Span may be calibrated independently. When replacing a sensor, both Zero and First Span calibrations shall be carried out.



CAUTION

Channel calibration is compulsory after changing the bead current (or catalytic sensor) of an AIM mV channel, and the channel stays in **Inhibit** until this is done.

Disable or inhibit any operations or actions that may result from gas readings before starting this test.

8.2.1 First Span

TPPR has the option of carrying out **First Span** or **Span**. Select **First Span** when calibrating a new or replacement sensor for the first time, and **Span** for all calibrations thereafter.



The signal voltage from catalytic sensors reduces over time. Regular recalibration is required to make allowance for these changes.

This slow change is monitored by TPPR and is used to give the sensor life expired warning when the Span value is $\leq 50\%$ of the First Span value.



CAUTION

When installing a new sensor the TPPR will use its default value if **First Span** is not used, which may result in a premature life expired warning or no warning at all!

Always use the same type and concentration of **Span Gas** to ensure accurate and consistent testing and calibration.

8.2.2 Calibration Procedure

To calibrate a mV input channel follow the procedure below, in conjunction with the relevant sensor manual.

The channel must be inhibited before calibration is allowed. If not already automatically inhibited, the channel can be inhibited from the Inputs icon popup menu or the Gas Calibration screen.

1. Login as an **Administrator** or **Engineer**
2. From the **System Status** screen select the Inputs icon then select the channel to be calibrated
3. Select **Inhibit** from the popup menu, if not already inhibited.
4. Select **Gas Calibration** from the popup menu

CALIBRATING GAS SENSORS

8.2.2.1 Zero Calibration



Figure 71. Calibration Screen

5. Select **Zero Adjust**, and when ready select **OK** and apply **Zero Gas** to the sensor
6. View the gas concentration reading until it is stable, and then select **Accept**

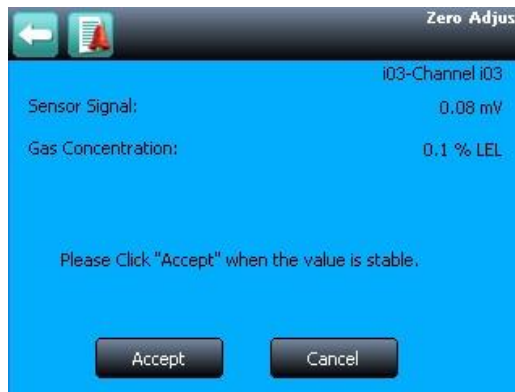

Figure 72. Zero Calibration Screen

7. Confirm that the displayed gas concentration reading is zero, and select **Save** then **OK**

8.2.2.2 Span Calibration

8. Select **First Span** or **Span** as appropriate. **First Span** must be used for the first calibration of a new sensor. **Span** is used for all subsequent calibrations.
9. The default concentration of span gas will be displayed. Replace the default Span Gas Concentration (50% LEL in the example below) with the actual gas concentration to be used, normally from the calibration gas cylinder. If cross calibrating with a different gas, enter the calculated equivalent value from the sensor manual.
10. Select **Accept**.

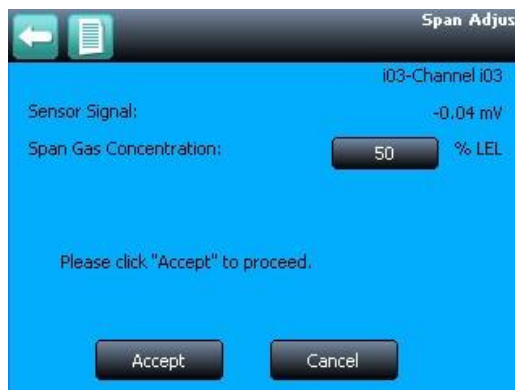

Figure 73. Enter Span Gas Concentration

11. When ready select **OK** and apply gas to the sensor

CALIBRATING GAS SENSORS

12. View the gas concentration reading until it is stable, and then select **Accept**

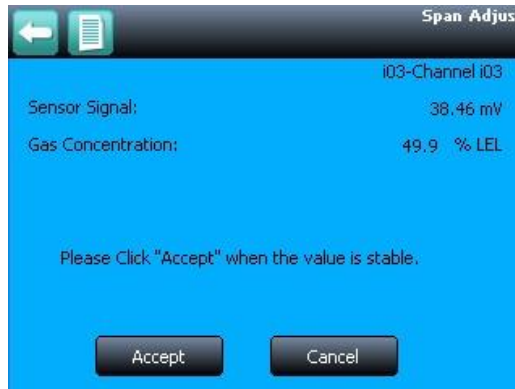

Figure 74. Span Gas Calibration screen

13. Confirm that the gas concentration reading is correct, and select **Save** then **OK**



Figure 75. Calibration Screen, Span

14. Remove the span gas from the sensor, and confirm that the gas concentration reading has returned to zero

15. Select **Clear Inhibit** to remove the channel inhibit

8.3 Calibrating AIM-mA Input Channel Loops

Touchpoint Pro supports both gas calibration of mA sensor and loop calibration of the transmitter 4-20mA current loop. TPPR can be programmed to display calibration reminders at calibration intervals, e.g. annually or every six months.

In general gas calibration should be carried out at the sensor, using the sensor's inbuilt calibration. Gas calibration of a sensor from TPPR should only be carried out on sensors without this capability.

The procedure is similar to the mV calibration above. For loop calibration the **Zero** and **Span** (4mA and 20mA) currents should be set using the transmitter's **Force** functions where available.



CAUTION

Wherever possible the TPPR mA loop should always be calibrated by forcing signal levels at the sensor / transmitter. Any gas calibration must be carried out at the field device according to the manufacturer's instructions.

Disable or inhibit any operations or actions that may result from gas readings before starting this test. The Touchpoint Pro controller calibration should not be used to adjust for deficiencies in the sensor / transmitter gas calibration. Failure to observe this can result in significant accuracy errors.

CALIBRATING GAS SENSORS

To calibrate a channel mA loop, follow the procedure below in conjunction with the relevant sensor manual.

The channel must be inhibited before calibration is allowed. The channel may be inhibited from the Inputs icon popup menu or the Gas Calibration screen.

1. Login as an **Administrator** or **Engineer**
2. From the **System Status** screen select the **Inputs** icon then select the channel to be calibrated
3. Select **Gas Calibration** from the popup menu

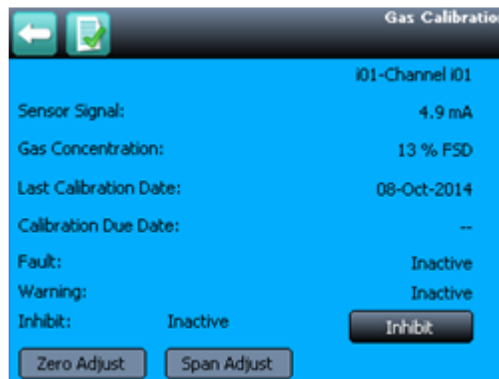

Figure 76. mA Calibration Screen

4. Select **Inhibit** to inhibit the channel, if not already inhibited.
5. Select **Zero Adjust**, and when ready select **OK**
6. Generate a zero signal at the sensor by forcing the output to 4 mA or if this function is not supported by applying **Zero Gas**
7. View the sensor signal reading until it is stable, and then select **Accept**

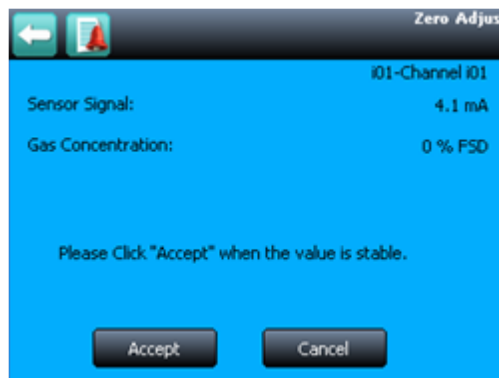

Figure 77. mA Zero Calibration

8. Confirm that the gas concentration reading is zero, and select **Save** then **OK**
9. Select **Span Adjust**

CALIBRATING GAS SENSORS

10. Replace the Span Gas Concentration default value (50% FSD in the example below) with the required figure:
 - a) If carrying out a loop calibration by forcing the output this will typically be 100% FSD, corresponding to 20mA.
 - b) If carrying out a direct gas calibration of a sensor, enter the span gas concentration to be used, normally from the cylinder label.
11. Select **Accept**

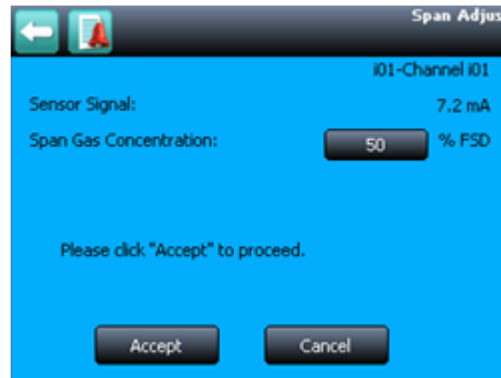

Figure 78. mA Span Calibration

12. When ready select **OK** and generate an equivalent gas reading at the sensor, either by forcing a value at the transmitter or applying span gas to the sensor.
13. View the signal reading until it is stable, and then select **Accept**
14. Confirm that the reading is correct, and select **Save** then **OK**
15. Return the sensor to normal operation, and confirm that the signal has returned to zero
16. Select **Clear inhibit** to remove the channel inhibit

CONFIGURATION

9 Configuring System Parameters

The TPPR System is fully configurable to match your local requirements, and the configurable parameters are set out in this section of the Technical Handbook.

Note: System Parameters are normally set in the factory and should only be changed by Authorised Honeywell Technicians or by qualified persons trained in accordance with the Touchpoint Pro Technical Handbook.

9.1 General Considerations

You should consider the following scale before configuring any system parameters. Note that **Over Range Warning** and **Full Scale Exceeded** peak values are shown on the trend display.



DANGER

A **Over Range Warning** may mean that the catalytic sensor has been flooded by a gas concentration beyond its design capacity, which could indicate that a potentially catastrophic situation has occurred. It is advisable to investigate fully before resetting alarms and it is therefore *inadvisable* to set the parameter to unlatched.

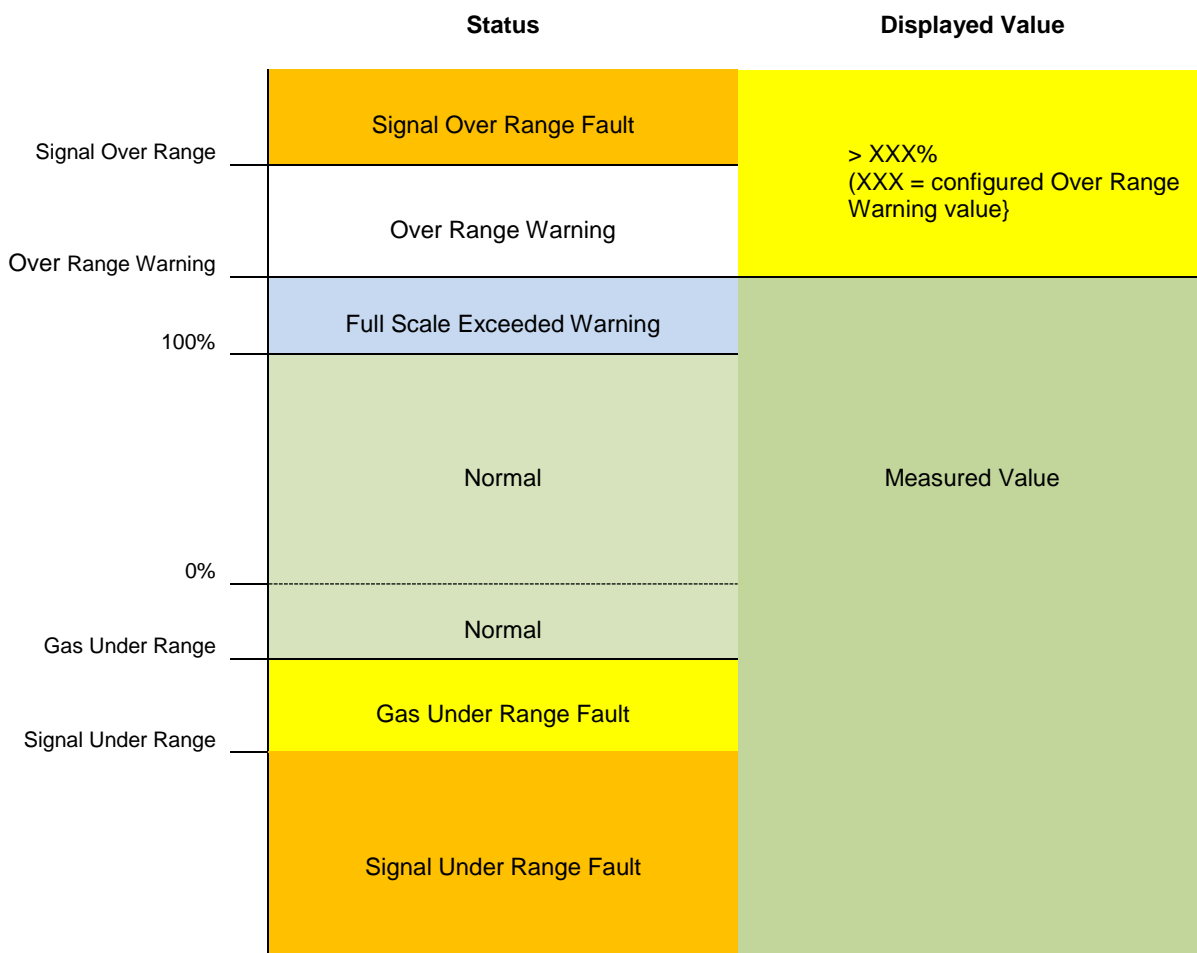

Figure 79. Programmable Signal Parameters

Note: Depending on the installation and sensor type, **Gas Under Range** optimal levels may be set to a minimum saturation level for inert or flammable gases, or to a minimum breathable level for Oxygen.

CONFIGURATION

9.1.1 Displayed Numeric Resolution

Touchpoint Pro displays numeric values to the following resolutions:

Number Range	Decimal Places
1000 to 99999	0
100 to 999.99	1
10 to 99.99	2
1 to 9.99	3
0.01 to 0.99	4

9.2 Analogue Input Module 4-20 mA Parameters

The Analogue Input Module 4-20 mA has the option to use the sensor catalogue (basic / extended), configure a custom channel, or copy from a configured channel (basic / extended).

Note: When making changes using extended options, it is the user's responsibility to determine whether other settings have been affected and to make any corresponding changes.

If a basic configuration is selected, only the first two screens detailed below will be used (**Commission Channel** and **Field Device Selection**). The rest of the configuration will be programmed automatically, either from the sensor catalogue or from the channel that is being copied.

Note: If a channel is configured from the sensor catalogue, it is possible to edit individual settings afterwards.

9.2.1.1 Configuring Custom Sensors

When configuring a custom sensor, it is the user's responsibility to select suitable units and ranges. TPPR does not check or validate all possible combinations.

9.2.2 Commission Channel

Access Level: **Administrator**

Parameter Name	Default Setting	Value Range	Comment
Channel ID	Next available	1 to 64	Can only be assigned during first time configuration. Otherwise de-commission the channel and re-assign another channel number
Channel Tag	'Channel <Channel ID>'	Maximum 30 Alphanumeric Characters	30 character location tag name. This is the main channel description used throughout the interface
Custom Channel ID	'Channel <Channel ID>'	Maximum 20 Alphanumeric Characters	20 character custom ID. This is displayed on the 'Channel Details' screen and in the Configuration Report

Note: **Channel Tag** and **Channel Custom ID** only require **Engineer** level access for editing.

CONFIGURATION

9.2.3 Field Device Selection

Access Level: **Administrator**

Parameter Name	Value Range	Comment
Field Device Type	Maximum 30 Alphanumeric Characters	If the sensor catalogue is used, a list of available field devices will be displayed for selection. If copy channel is being used, this value cannot be changed
Sensor Variant	Maximum 30 Alphanumeric Characters	If the sensor catalogue is used, a list of available gases and ranges will be displayed for selection. If copy channel is being used, this value cannot be changed

9.2.4 Sensor Settings

Access Level: **Administrator**

Parameter Name	Value Range	Comment
Gas Name	Maximum 10 Alphanumeric Characters	
Gas Unit	%FSD, %LEL, % Vol., ppm, ppb, mA, mV, mg/m3, LEL.m or maximum 5 Alphanumeric Characters	FSD – Full Scale Deflection LEL – Lower Explosive Limit LEL.m – LEL metres

9.2.5 Range Settings

Access Level: **Administrator**

Parameter Name	Default Setting	Value Range	Comment
Signal Range Min	4 mA	0.5 mA to 4 mA	x = Measured signal value X1 = Signal Range Min (Electrical input from Sensor) X2 = Signal Range Max (Electrical input from Sensor) Y1 = Gas Range Min Y2 = Gas Range Max Gas concentration (y) is calculated as follows: $y = ((Y2-Y1)/(X2-X1))*(x-X1)+Y1$
Signal Range Max	20 mA	12 mA to 24 mA	
Gas Range Min	0	0 to 99999 depending on selected sensor type.	
Gas Range Max	Depends on sensor type selected	0.01 to 99999 depending on selected sensor type.	

9.2.6 Display Settings

Access Level: **Administrator**

Parameter Name	Default Setting	Value Range	Comment
Full Scale Exceeded Enable	Enabled for mV channels Disabled for mA channels	Enabled / Disabled	The Full Scale Exceeded warning is set if the gas reading rises above the configured full scale value and it clears when the value falls below the full scale value. The peak value may be seen in the Trend graph.

CONFIGURATION

9.2.7 Suppression Settings

Access Level: **Engineer**

The gas concentration is set to zero when the gas concentration value received from the sensor is between the 'Zero suppression Positive' and 'Zero suppression Negative' values.

Parameter Name	Default Setting	Minimum	Maximum
Zero Suppression Positive	Depends on sensor type selected	Gas Range Min	Gas Range Min + 0.25*(Gas Range Max – Gas Range Min)
Zero Suppression Negative		Gas Range Min – 0.25*(Gas Range Max – Gas Range Min)	Gas Range Min

Note: Trend logging takes place when the values of an input channel change. The system will not log values while they remain within the zero suppression limits.

Note: If a threshold alarm level is set within the zero suppression band, the alarm signal will not be generated.

9.2.8 Threshold Alarm 1 Settings

Access Level: **Engineer**

Parameter Name	Default Setting	Value Range
Alarm 1 Enable	Enabled	Enabled / Disabled
Alarm 1 Level	Gas Range Min + NN *(Gas Range Min - Gas Range Min)	Gas Range Min to Gas Range Max
Alarm 1 Trigger	Rising	Rising / Falling
Alarm 1 Latch	Latching	Non-Latching / Latching

Note: **NN** depends on sensor type selected, typically 0.20 (20%).

9.2.9 Threshold Alarm 2 Settings

Access Level: **Engineer**

Parameter Name	Default Setting	Value Range
Alarm 2 Enable	Enabled	Enabled / Disabled
Alarm 2 Level	Gas Range Min + NN *(Gas Range Max - Gas Range Min)	Gas Range Min to Gas Range Max
Alarm 2 Trigger	Rising	Rising / Falling
Alarm 2 Latch	Latching	Non-Latching / Latching

Note: **NN** depends on sensor type selected, typically 0.50 (50%).

CONFIGURATION

9.2.10 Threshold Alarm 3 Settings

Access Level: **Engineer**

Parameter Name	Default Setting	Value Range
Alarm 3 Enable	Enabled	Enabled / Disabled
Alarm3 Level	Gas Range Min + NN *(Gas Range Min - Gas Range Min)	Gas Range Min to Gas Range Max
Alarm3 Trigger	Rising	Rising / Falling
Alarm3 Latch	Latching	Non-Latching / Latching

Note: **NN** depends on sensor type selected, typically 0.75 (75%).

9.2.11 Threshold Alarm Hysteresis

Access Level: **Engineer**

The hysteresis value will be applied to a channel coming out of an alarm condition, e.g. if the alarm level is 20 %FSD, and hysteresis is set to 2 %, the alarm will not be cancelled until the reading has dropped below 18 %FSD.

Parameter Name	Default Setting	Minimum	Maximum
Threshold Alarm Hysteresis	0.02*(Gas Range Max - Gas Range Min)	0	0.1*(Gas Range Max - Gas Range Min)

9.2.12 STEL Alarm Settings

Access Level: **Engineer**. Refer to Chapter 10 Configuring STEL and LTEL Alarms.

Parameter Name	Default Setting	Value Range
STEL Alarm Enable	Disabled	Enabled / Disabled
STEL Alarm Level	Gas Range Min + NN *(Gas Range Min - Gas Range Min)	Gas Range Min to Gas Range Max
STEL Alarm Interval	15	5 to 60 minutes
STEL Alarm Latch	Latching	Non-Latching / Latching

Note: **NN** depends on sensor type selected.

9.2.13 LTEL Alarm Settings

Access Level: **Engineer**. Refer to Chapter 10 Configuring STEL and LTEL Alarms.

Parameter Name	Default Setting	Value Range
LTEL Alarm Enable	Disabled	Enabled / Disabled
LTEL Alarm Level	Gas Range Min + NN *(Gas Range Min - Gas Range Min)	Gas Range Min to Gas Range Max
(TWA) Start Time of the First Shift	Not used	
LTEL Alarm Latch	Latching	Non-Latching / Latching

Note: **NN** depends on sensor type selected.

CONFIGURATION

9.2.14 Rate Alarm Settings 1

The **Rate of Change Alarm** is triggered when a specific rate of rise or fall is observed (the **Rate Alarm Trigger** can be set as **Rising** or **Falling**).

The **Alarm Level** and the **Alarm Interval** can be configured. E.g. If the **Alarm Level = 10 %LEL** and the **Alarm Interval = 5 s**, the **Rate Alarm** triggers if the concentration has risen by **10 %LEL within 5 s**.

The rate alarm is calculated from the displayed reading.

Note: If zero suppression is used it has the effect of sensitizing the rate alarm. It is recommended to set the rate alarm to twice the suppression band value to avoid nuisance alarms.

Access Level: **Engineer**

Parameter Name	Default Setting	Value Range
Rate Alarm Enable	Disabled	Enable / Disable
Rate Alarm Level	0.05*(Gas Range Max - Gas Range Min)	Gas Range Min to Gas Range Max
Rate Alarm Trigger	Rising	Rising / Falling
Rate Alarm Latch	Latching	Non-Latching / Latching

Note: Rate Alarms should always be set to Latching or connected to a latching input on other equipment. A non-latching alarm will only be displayed whilst the rate is exceeded. The alarm will reset when the gas concentration achieves full scale or the gas rate falls below the set rate.

9.2.15 Rate Alarm Settings 2

Access Level: **Engineer**

Parameter Name	Default Setting	Value Range	Comment
Rate Alarm Time Interval	1 s	1 s to 30 s	Determines the Rate Alarm evaluation interval.

9.2.16 Inhibit Delay Settings

Access Level: **Engineer**

Parameter Name	Default Setting	Value Range	Comment
Power-On Delay Enable	Enabled	Enabled / Disabled	If enabled, the channel will be inhibited for a specific time interval (the Inhibit Delay Time) after power-up in order to prevent false alarms (e.g. during sensor warm-up). If disabled, the channel is inhibited for a fixed 5 second delay.
Fault Recovery Delay Enable	Enabled	Enabled / Disabled	If enabled, the channel will be inhibited for a specific time interval (the Inhibit Delay Time) after a channel fault condition has been cleared in order to prevent false alarms (e.g. due to sensor recovery). If disabled, the channel is inhibited for a fixed 5 second delay.
Inhibit Delay Time	30 s	5 to 3000 s	This is the delay time before a channel returns to normal operation if the Power-On Delay or the Fault Recovery Delay is enabled.

CONFIGURATION

9.2.17 Signal Range Fault Settings

Note: When setting up the **Gas Over / Under Range** and **Signal Over / Under Range** limits, take account of any diagnostic signals that may be generated by the field device under and over the measuring range. Failure to do so may result in confusing or misleading messages. Remember that up to **5 Custom Transmitter Faults** and **Inhibit Signalling** are available, so that diagnostic information from the transmitter can be clearly understood.

Note: When commissioning or testing sensors with a **Transmitter**, check that all fault messages in the Touchpoint Pro settings match the 4-20 mA transmitter specification.

Some typical diagnostic signal levels and equivalent %FSD values that may be used by intelligent transmitters are given below:

Diagnostic level	Equivalent %FSD
22 mA	112.5 %
21 mA	106.25 %
3 mA	-6.25 %
2.5 mA	-9.4 %
2 mA	-12.5 %
1.5 mA	-15.6 %
1 mA	-18.75 %

Access Level: **Engineer**

Parameter Name	Default Setting	Value Range	Comment
Signal Under Range Limit	1.5mA	0.7 to 4.0 mA	The 'Signal Under Range Fault' will be set if the sensor signal reading is less than the configured 'Signal Under Range Limit'.
Signal Under Range Latch	Latching	Non-Latching / Latching	
Signal Over Range Limit	22.0mA	20.0 to 24.0 mA	The 'Signal Over Range Fault' will be set if the sensor signal reading is greater than the configured 'Signal Over Range Limit'.
Signal Over Range Latch	Latching	Non-Latching / Latching	

CONFIGURATION

9.2.18 Gas Range Fault Settings

Access Level: **Engineer**

The 'Gas Under Range Fault' will be set if the calculated gas concentration is less than the configured 'Gas Under Range Limit'. This fault may be due to the sensor signal drifting below the normal zero operating point.

Parameter Name	Default Setting	Value Range	
		Minimum	Maximum
Under Range Fault Limit	Gas Range Min- 0.10 * (Gas Range Max- Gas Range Min)	Gas Range Min – 0.24 * (Gas Range Max - Gas Range Min)	Gas Range Min
Under Range Fault Latch	Latching	Non-Latching / Latching	

The 'Over Range Limit Warning' will be set if the calculated gas concentration is greater than the configured limit.

Note: If the Over Range Warning signal is latched, **an extra Reset operation is required**. The first Reset clears the over range warning, the second reset clears any other conditions.

Parameter Name	Default Setting	Value Range	
		Minimum	Maximum
Over Range Warning Limit	Gas Range Max+ 0.10 * (Gas Range Max- Gas Range Min)	Gas Range Min	Gas Range Max+ 0.25 * (Gas Range Max- Gas Range Min)
Over Range Warning Latch	Latching	Non-Latching / Latching	

9.2.19 Calibration Reminder Settings

Access Level: **Engineer**

Parameter Name	Default Setting	Value Range	Comment
Calibration Reminder Enable	Disabled	Enabled / Disabled	'Calibration Overdue Warning' is set if the 'Calibration Reminder Interval' is exceeded.
Calibration Reminder Interval	6 months	1 to 24 months	Calibration reminder is calculated to the day, e.g. if the reminder is set on 27 January for 6 months' time, the calibration overdue reminder will appear on 27 July.

Note: Once the **Calibration Overdue Warning** is active, it can only be cleared by calibrating the channel.

CONFIGURATION

9.2.20 Calibration Signal Settings

Access Level: **Engineer**

Note: These settings refer to the range of signal values from the sensor over which calibration will be permitted, and are used to avoid incorrect calibration e.g. due to incorrect application of gas.

Parameter Name	Default Setting	Value Range	Comment
Maximum Zero Offset	5 mA	1 to 15 mA	During calibration, the 'Zero Signal Too High' warning is set if the zero signal exceeds the Maximum Zero Offset
Minimum Zero Offset	3 mA	1 to 8 mA	During calibration, the 'Zero Signal Too Low' warning is set if the zero signal is below the Minimum Zero Offset
Maximum Span Signal	20.0 mA	8.0 to 24.0 mA	During calibration, the 'Calibration Signal Too High' warning will be set if the span signal exceeds the Maximum Span Signal.
Minimum Span Signal	5 mA	0.0 to 12.0 mA	During calibration, the 'Calibration Signal Too Low' warning will be set if the span signal is below the Minimum Span Signal

9.2.21 Calibration Span Gas Settings

Access Level: **Engineer**

These settings refer to the range of gas concentration values that can be used for span calibration, and are used to ensure that the sensor is calibrated at an appropriate level.

The **Maximum Span Gas Concentration** and **Minimum Span Gas Concentration** are the maximum and minimum values that can be entered into the *Span Gas Concentration* field during calibration.

The **Default Span Gas Concentration** is the value initially displayed in the *Span Gas Concentration* field. This may be changed by the user during calibration to match the actual gas concentration used.

Parameter Name	Default Setting	Value Range	
		Minimum	Maximum
Maximum Span Gas Concentration	Gas Range Max	Gas Range Max - 0.20 * (Gas Range Max - Gas Range Min)	Gas Range Max
Minimum Span Gas Concentration	Gas Range Min + MN * (Gas Range Max - Gas Range Min)	Gas Range Min + 0.15 * (Gas Range Max - Gas Range Min)	Gas Range Max - 0.20 * (Gas Range Max - Gas Range Min)
Default Span Gas Concentration	Gas Range Max - NN * (Gas Range Max - Gas Range Min)	Gas Range Max - 0.70 * (Gas Range Max - Gas Range Min)	Gas Range Max

Note: **MN** and **NN** depend on the sensor type selected.

CONFIGURATION

9.2.22 Inhibit Signalling Settings

Access Level: **Engineer**

Parameter Name	Default Setting	Value Range	Comment
Inhibit Signalling Enable	Disabled	Enabled / Disabled	If enabled, a specific signal level from the sensor will activate an inhibit condition for the channel.
Inhibit Level Max	1.0 mA	1.0 to 3.9 mA	The recommended minimum difference between Inhibit Level Max and Inhibit Level Min is 0.2 mA
Inhibit Level Min	2.0 mA	0.8 to 3.9 mA	

9.2.23 Fault Signalling Settings 1

Access Level: **Engineer**

Parameter Name	Default Setting	Value Range	Comment
Custom Event 1 Enable	Disabled	Enabled / Disabled	If enabled, a specific signal level from the sensor will activate a custom fault condition for the channel. An example of a custom fault is the 'Beam Block' condition for an open path IR detector
Custom Event 2 Enable	Disabled	Enabled / Disabled	
Custom Event 3 Enable	Disabled	Enabled / Disabled	

9.2.24 Fault Signalling Settings 2

Access Level: **Engineer**

Parameter Name	Default Setting	Value Range	Comment
Custom Event 4 Enable	Disabled	Enabled / Disabled	If enabled, a specific signal level from the sensor will activate a custom fault condition for the channel. An example of a custom fault is the 'Beam Block' condition for an open path IR detector
Custom Event 5 Enable	Disabled	Enabled / Disabled	

CONFIGURATION

9.2.25 Custom Fault 'X' Detail Settings

The Fault details can be set for each of the enabled custom faults.

Access Level: **Engineer**

Parameter Name	Default Setting	Value Range	Comment
Custom Event (1-5) Name	'Custom Fault 1'	Maximum 20 Alphanumeric Characters	This is the fault description, which will be displayed on the 'Input Details' screen
Custom Event (1-5) Level Max	3.0 mA	1.0 to 3.9 mA	The recommended minimum difference between Fault Level Max and Fault Level Min is 0.2 mA
Custom Event (1-5) Level Min	2.0 mA	0.8 to 3.8 mA	
Custom Event (1-5) Latch	Latching	Non-Latching / Latching	
Custom Event (1-5) Type	Fault	Fault / Warning	Select whether the 'custom fault' should be treated as a fault condition or as a warning condition.

9.3 Analogue Input Module mV Bridge Parameters

The **Analogue Input Module mV Bridge** has the option to use the sensor catalogue (basic / extended), configure a custom channel, or copy from a configured channel (basic / extended).

Note: When making changes using extended options, it is the user's responsibility to determine whether other settings have been affected and to make any corresponding changes.

If a basic configuration is selected, only the first two screens detailed below will be used (**Commission Channel** and **Field Device Selection**). The rest of the configuration will be programmed automatically, either from the sensor catalogue or from the channel that is being copied.

Note: If a channel is configured from the sensor catalogue, it is possible to edit individual settings afterwards.

Note: For catalytic bead type detectors, the Touchpoint Pro controller is necessary to complete the measuring circuit. Therefore all commissioned mV channels remain in Inhibit state until they are calibrated.

9.3.1.1 Configuring Custom Sensors

When configuring a custom sensor, it is the user's responsibility to select suitable units and ranges. TPPER does not check or validate all possible combinations.

9.3.2 Commission Channel

Access Level: **Administrator**

Parameter Name	Default Setting	Value Range	Comment
Channel ID	Next available	1 to 64	Can only be assigned during first time configuration. Otherwise de-commission the channel and re-assign another channel number
Channel Tag	'Channel <Channel ID>'	Maximum 30 Alphanumeric Characters	30 character location tag name. This is the main channel description used throughout the interface
Custom Channel ID	'Channel <Channel ID>'	Maximum 20 Alphanumeric Characters	20 character custom ID. This is displayed on the 'Channel Details' screen and in the Configuration Report

Note: **Channel Tag** and **Channel Custom ID** only require **Engineer** level access for editing.

CONFIGURATION

9.3.3 Field Device Selection

Access Level: **Administrator**

Parameter Name	Value Range	Comment
Field Device Type	Maximum 30 Alphanumeric Characters	If the sensor catalogue is used, a list of available field devices will be displayed for selection. If copy channel is being used, this value cannot be changed
Sensor Variant	Maximum 30 Alphanumeric Characters	If the sensor catalogue is used, a list of available gases and ranges will be displayed for selection. If copy channel is being used, this value cannot be changed

9.3.4 Sensor Settings

Access Level: **Administrator**

Parameter Name	Default Setting	Value Range	Comment
Gas Name		Maximum 10 Alphanumeric Characters	
Gas Unit		%FSD, %LEL, % Vol., ppm, ppb, mA, mV, mg/m3, LEL.m or maximum 5 Alphanumeric Characters	FSD – Full Scale Deflection LEL – Lower Explosive Limit LEL.m – LEL metres
Bridge Current	200 mA	180 to 360 mA	

9.3.5 Range Settings

Access Level: **Administrator**

Parameter Name	Default Setting	Value Range	Comment
Signal Range Min	0	0 mV to 100 mV	x = Measured signal value $X1$ = Signal Range Min (Electrical input from Sensor) $X2$ = Signal Range Max (Electrical input from Sensor) $Y1$ = Gas Range Min $Y2$ = Gas Range Max Gas concentration (y) is calculated as follows: $y = (((Y2-Y1)/(X2-X1)) * (x-X1)) + Y1$ Note: Signal Range Min and Max are over-written during calibration, and are then no longer editable
Signal Range Max	Depends on sensor type selected	5 mV to 300 mV	
Gas Range Min	0	0 to 99999 depending on selected sensor type.	
Gas Range Max	Depends on sensor type selected	0.01 to 99999 depending on selected sensor type.	

CONFIGURATION

9.3.6 Display Settings

Access Level: **Administrator**

Parameter Name	Default Setting	Value Range	Comment
Full Scale Exceeded Enable	Enabled for mV channels Disabled for mA channels	Enabled / Disabled	The Full Scale Exceeded warning is set if the gas reading rises above the configured full scale value and it clears when the value falls below the full scale value. The peak value may be seen in the Trend graph.

Note: If the gas value rises above the configured **Over Range Warning** setting, the **Full Scale Exceeded** warning is replaced by the **Over Range Warning**. Refer to section 9.3.16

9.3.7 Suppression Settings

Access Level: **Engineer**

The gas concentration is set to zero when the gas concentration value received from the sensor is between the 'Zero suppression Positive' and 'Zero suppression Negative' values.

Parameter Name	Default Setting	Minimum	Maximum
Zero Suppression Positive	Depends on sensor type selected	Gas Range Min	Gas Range Min + 0.25*(Gas Range Max – Gas Range Min)
Zero Suppression Negative		Gas Range Min – 0.25*(Gas Range Max – Gas Range Min)	Gas Range Min

Note: Trend logging takes place when the values of an input channel change. The system will not log values while they remain within the zero suppression limits.

Note: If a threshold alarm level is set within the zero suppression band, the alarm signal will not be generated.

9.3.8 Threshold Alarm 1 Settings

Access Level: **Engineer**

Parameter Name	Default Setting	Value Range
Alarm 1 Enable	Enabled	Enabled / Disabled
Alarm 1 Level	Gas Range Min + NN *(Gas Range Max - Gas Range Min)	Gas Range Min to Gas Range Max
Alarm 1 Trigger	Rising	Rising / Falling
Alarm 1 Latch	Latching	Non-Latching / Latching

Note: **NN** depends on sensor type selected, typically 0.20 (20%).

CONFIGURATION

9.3.9 Threshold Alarm 2 Settings

Access Level: **Engineer**

Parameter Name	Default Setting	Value Range
Alarm 2 Enable	Enabled	Enabled / Disabled
Alarm 2 Level	Gas Range Min + NN *(Gas Range Max - Gas Range Min)	Gas Range Min to Gas Range Max
Alarm 2 Trigger	Rising	Rising / Falling
Alarm 2 Latch	Latching	Non-Latching / Latching

Note: **NN** depends on sensor type selected, typically 0.50 (50%).

9.3.10 Threshold Alarm 3 Settings

Access Level: **Engineer**

Parameter Name	Default Setting	Value Range
Alarm 3 Enable	Enabled	Enabled / Disabled
Alarm3 Level	Gas Range Min + NN *(Gas Range Max - Gas Range Min)	Gas Range Min to Gas Range Max
Alarm3 Trigger	Rising	Rising / Falling
Alarm3 Latch	Latching	Non-Latching / Latching

Note: **NN** depends on sensor type selected, typically 0.75 (75%).

9.3.11 Threshold Alarm Hysteresis

Access Level: **Engineer**

The hysteresis value will be applied to a channel coming out of an alarm condition, e.g. if the alarm level is 20 %FSD, and hysteresis is set to 2 %, the alarm will not be cancelled until the reading has dropped below 18 %FSD.

Parameter Name	Default Setting	Minimum	Maximum
Threshold Alarm Hysteresis	0.02*(Gas Range Max - Gas Range Min)	0	0.1*(Gas Range Max - Gas Range Min)

CONFIGURATION

9.3.12 Rate Alarm Settings 1

Note: The **Rate of Change Alarm** is set when a specific rate of rise (or fall; depending if the **Rate Alarm Trigger** is set as **Rising** or **Falling**) is observed. The **Alarm Level** and the **Alarm Interval** can be configured. If the **Alarm Level = 10 %LEL** and the **Alarm Interval = 5 s**, the **Rate Alarm** will be set if the concentration has risen by **10 %LEL within 5 s**.

The rate alarm is calculated from the displayed reading.

Note: If zero suppression is used it has the effect of sensitizing the rate alarm. It is recommended to set the rate alarm to twice the suppression band value to avoid nuisance alarms.

Access Level: **Engineer**

Parameter Name	Default Setting	Value Range
Rate Alarm Enable	Disabled	Enable / Disable
Rate Alarm Level	0.05*(Gas Range Max - Gas Range Min)	Gas Range Min to Gas Range Max
Rate Alarm Trigger	Rising	Rising / Falling
Rate Alarm Latch	Latching	Non-Latching / Latching

Note: Rate Alarms should always be set to Latching or connected to a latching input on other equipment. A non-latching alarm will only be displayed whilst the rate is exceeded. The alarm will reset when the gas concentration achieves full scale or the gas rate falls below the set rate.

9.3.13 Rate Alarm Settings 2

Access Level: **Engineer**

Parameter Name	Default Setting	Value Range	Comment
Rate Alarm Time Interval	1 s	1 s to 30 s	Determines the Rate Alarm evaluation interval.

9.3.14 Inhibit Delay Settings

Access Level: **Engineer**

Parameter Name	Default Setting	Value Range	Comment
Power-On Delay Enable	Enabled	Enabled / Disabled	If enabled, the channel will be inhibited for a specific time interval (the Inhibit Delay Time) after power-up in order to prevent false alarms (e.g. during sensor warm-up). If disabled, the channel is inhibited for a fixed 5 second delay.
Fault Recovery Delay Enable	Enabled	Enabled / Disabled	If enabled, the channel will be inhibited for a specific time interval (the Inhibit Delay Time) after a channel fault condition has been cleared in order to prevent false alarms (e.g. due to sensor recovery). If disabled, the channel is inhibited for a fixed 5 second delay.
Inhibit Delay Time	30 s	5 to 3000 s	This is the delay time before a channel returns to normal operation if the Power-On Delay or the Fault Recovery Delay are enabled.

CONFIGURATION

9.3.15 Signal Range Fault Settings

Access Level: **Engineer**

Parameter Name	Default Setting	Value Range	Comment
Signal Under Range Limit	-50 mV	-90 to -5 mV	The 'Signal Under Range Fault' will be set if the sensor signal reading is less than the configured 'Signal Under Range Limit'.
Signal Under Range Latch	Latching	Non-Latching / Latching	
Signal Over Range Limit	300 mV	25 to 360 mV	The 'Signal Over Range Fault' will be set if the sensor signal reading is greater than the configured 'Signal Over Range Limit'.
Signal Over Range Latch	Latching	Non-Latching / Latching	

9.3.16 Gas Range Fault Settings

Access Level: **Engineer**

The 'Gas Under Range Fault' will be set if the calculated gas concentration is less than the configured 'Gas Under Range Limit'. This fault may be due to the sensor signal drifting below the normal zero operating point.

Parameter Name	Default Setting	Value Range	
		Minimum	Maximum
Under Range Fault Limit	Gas Range Min- 0.10 * (Gas Range Max- Gas Range Min)	Gas Range Min – 0.24 * (Gas Range Max - Gas Range Min)	Gas Range Min
Under Range Fault Latch	Latching	Non-Latching / Latching	

The 'Over Range Limit Warning' will be set if the calculated gas concentration is greater than the configured limit.

Note: If the Over Range Warning signal is latched, **an extra Reset operation is required**. The first Reset clears the over range warning, the second reset clears any other conditions.

Parameter Name	Default Setting	Value Range	
		Minimum	Maximum
Over Range Warning Limit	Gas Range Max+ 0.10 * (Gas Range Max- Gas Range Min)	Gas Range Min	Gas Range Max+ 0.25 * (Gas Range Max- Gas Range Min)
Over Range Warning Latch	Latching	Non-Latching / Latching	

9.3.17 Calibration Reminder Settings

Access Level: **Engineer**

Parameter Name	Default Setting	Value Range	Comment
Calibration Reminder Enable	Disabled	Enabled / Disabled	'Calibration Overdue Warning' is set if the 'Calibration Reminder Interval' is exceeded.
Calibration Reminder Interval	6 months	1 to 24 months	Calibration reminder is calculated to the day, e.g. if the reminder is set on 27 January for 6 months' time, the calibration overdue reminder will appear on 27 July.

Note: Once the **Calibration Overdue Warning** is active, it can only be cleared by calibrating the channel.

CONFIGURATION

9.3.18 Calibration Signal Settings

Access Level: **Engineer**

Note: These settings refer to the range of signal values from the sensor over which calibration will be permitted, and are used to avoid incorrect calibration e.g. due to a decaying sensor or incorrect application of gas.

Parameter Name	Default Setting	Value Range	Comment
Maximum Zero Offset	100 mV	100mV	Not used – Should be set to 100mV
Minimum Zero Offset	-90 mV	-90mV	Not used – Should be set to -90mV
Maximum Span Signal	100 mV	100 to 300 mV	Maximum allowable signal at 100% FSD for new beads. Note: This is scaled by the span gas concentration entered in the <i>Span Gas Concentration</i> field
Minimum Span Signal	0 mV	-50 to 100 mV	Minimum allowable signal at 100% FSD for aged beads. Note: This is scaled by the span gas concentration entered in the <i>Span Gas Concentration</i> field

9.3.19 Calibration Span Gas Settings

Access Level: **Engineer**

These settings refer to the range of gas concentration values that can be used for span calibration, and are used to ensure that the sensor is calibrated at an appropriate level.

The **Maximum Span Gas Concentration** and **Minimum Span Gas Concentration** are the maximum and minimum values that can be entered into the *Span Gas Concentration* field during calibration.

The **Default Span Gas Concentration** is the value initially displayed in the *Span Gas Concentration* field. This may be changed by the user during calibration to match the actual gas concentration used.

Parameter Name	Default Setting	Value Range	
		Minimum	Maximum
Maximum Span Gas Concentration	Gas Range Max	Gas Range Max - 0.20 * (Gas Range Max - Gas Range Min)	Gas Range Max
Minimum Span Gas Concentration	Gas Range Min + MN * (Gas Range Max - Gas Range Min)	Gas Range Min + 0.15 * (Gas Range Max - Gas Range Min)	Gas Range Max - 0.20 * (Gas Range Max - Gas Range Min)
Default Span Gas Concentration	Gas Range Max - NN * (Gas Range Max - Gas Range Min)	Gas Range Max - 0.70 * (Gas Range Max - Gas Range Min)	Gas Range Max

Note: **MN** and **NN** depend on the sensor type selected.

CONFIGURATION

9.4 Digital Input Module Parameters

The **Digital Input Module (DIM)** has the option to configure a blank channel, or copy from a configured channel.

Note: If a channel is configured by copying from another channel, it is possible to edit individual settings.

Digital Input channels may be configured to generate Alarm, Fault or Warning events. Alternatively, using the Remote Interaction options, they may be used to remotely Reset, Inhibit, or Acknowledge one or more selected channels.

9.4.1 Commission Channel

Access Level: **Administrator**

Parameter Name	Default Setting	Value Range	Comment
Channel ID	Next available	1 to 64	Can only be assigned during first time configuration. Otherwise de-commission the channel and re-assign another channel number
Channel Tag	'Channel <Channel ID>'	Maximum 30 Alphanumeric Characters	30 character location tag name. This is the main channel description used throughout the interface
Channel Custom ID	'Channel <Channel ID>'	Maximum 20 Alphanumeric Characters	20 character custom ID. This is displayed on the 'Channel Details' screen and in the Configuration Report

Note: Channel Tag and Channel Custom ID only require **Engineer** level access for editing

9.4.2 Digital Input Settings

Access Level: **Engineer**

Parameter Name	Default Setting	Value Range	Comment
Input Type	Supervised OC/SC	Unsupervised / Supervised OC / Supervised OC/SC	A digital input (usually a switch) can be connected unsupervised, supervised for open circuit (OC) or supervised for both open circuit and short circuit (SC). See Electrical Installation, Connections, Digital Input Module for details
Default State	Normally Open (NO) for Standard modules / Normally Closed (NC) for Safe modules	Normally Closed (NC) / Normally Open (NO)	This parameter is not configurable for a SIL input channel

9.4.3 Event Settings

Access Level: **Engineer**

Parameter Name	Default Setting	Value Range	Comment
Input Latch	Latching	Non-Latching / Latching	—
Event Type	Alarm	Alarm, Fault, Warning, Remote Interaction	When configured as Alarm, the channel is treated as an AL1 if included in a Cause and Effect Matrix.

CONFIGURATION

9.4.4 Remote Interaction Settings

Access Level: **Engineer**

Note: Confirmation messages may not be displayed on the touch screen when channels are controlled from a DIM in Remote Interaction mode.

Parameter Name	Default Setting	Value Range	Comment
Remote Reset Enable	Disabled	Enabled / Disabled	The digital input can be used to reset latched alarm conditions or latched output channels.
Remote Inhibit Enable	Disabled	Enabled / Disabled	The digital input can be used to inhibit input- or output channels.
Remote Acknowledge Enable	Disabled	Enabled / Disabled	The digital input can be used to acknowledge alarm conditions.

9.4.5 Group Remote Interaction Settings

Access Level: **Engineer**

If any of the remote interaction options are enabled above, select **Add / View Group Member** to choose the channels to associate with the **Reset, Inhibit** or **Acknowledge** action.

Configuration is simplified if the required channels are all commissioned **before** configuring the Remote Interaction options.

- Channels can be assigned to more than one interaction group.
- A DIM channel assigned to carry out a remote interaction is not available to take part in any other interaction group.

Note: The **Remote Group Settings** screen may be displayed when Remote Interaction is not selected, and should then be ignored.

9.4.6 Use with Catalytic Sensors

Since a remote user cannot see information on the touch screen, Remote Interaction should be used with caution. In particular, Remote Reset should not be used with catalytic sensors.



WARNING

Remote reset should not be used for catalytic sensors, since gas could still be present even though the sensor reading has dropped. Conditions at the field device should always be investigated before resetting an alarm.

CONFIGURATION

9.5 Relay Output Module Parameters

Relay Output Module (ROM) channels may be configured as blank channels, or by copying an existing configured channel. If configured by copying another channel, it is possible to edit individual settings.

Note that if there is a system failure all ROM module relays will de-energise, regardless of their configured states.

9.5.1 Commission Channel

Access Level: **Administrator**

Parameter Name	Default Setting	Value Range	Comment
Channel ID	Next available	1 to 128	Can only be assigned during first time configuration. Otherwise de-commission the channel and re-assign another channel number
Channel Tag	'Channel <Channel ID>'	Maximum 30 Alphanumeric Characters	30 character location tag name. This is the main channel description used throughout the interface
Channel Custom ID	'Channel <Channel ID>'	Maximum 20 Alphanumeric Characters	20 character custom ID. This is displayed on the 'Channel Details' screen and in the Configuration Report

Note: Channel Tag and Channel Custom ID only require **Engineer** level access for editing

9.5.2 Relay Output Settings

Access Level: **Engineer**

Parameter Name	Default Setting	Value Range	Comment
Normal State	De-energised	De-energised / Energised	The NC contact is closed
Latch Function	Non-Latching	Non-Latching / Latching	The alarm conditions are usually already configured as latching; therefore the output channel is configured non-latching as the default setting.
Delay Time	00m:00s	00m:00s to 05m:00s	The output module will activate the output channel after the 'Delay Time' interval has expired. This only applies for the transition 'normal to active'.
Hold Time	00m:00s	00m:00s to 60m:00s	The output module will set the output channel into normal condition after the 'Hold Time' interval has expired. This only applies for the transition 'active to normal' and only if the output is configured as non-latching.
Auxiliary Output Enable	Disabled	Enabled / Disabled	If enabled the system will report any auxiliary output overload as a fault. The overload condition applies to the module, so it will be reported on all enabled channels.
Alarm Update Enable	Enabled	Enabled / Disabled	If enabled, only unacknowledged alarm conditions will be considered during C&E evaluation for this output channel. An alarm acknowledgement will reset a relay output that is configured for alarm update function. However if the alarm update is NOT enabled the relay contact will only be reset if the alarm is reset.
Action on New Event	Steady	Steady / Pulsed	Default is set to hold the relay on, but could be set to pulse the output, e.g. for a beacon or sounder.

Note: Action on New Event only applies if Alarm Update function is enabled.

CONFIGURATION

9.5.3 Cause and Effect Type Selection

A **Relay Output** channel can be configured as a **'Master'** relay, which activates if any specific condition is present anywhere in the system (e.g. Alarm 1), or as a **'Normal'** relay, which activates according to the programmed **Cause and Effect matrix** for that channel.

9.5.4 Output Type

Select the required Output Type, Master or Normal, as required.

9.5.5 Event Selection for Master Channel

The master selection option uses a screen similar to that below:

ID/Location		AL1	AL2	AL3	FLT	INH	WRN
Select All	Current Value	<input checked="" type="checkbox"/>	<input type="checkbox"/>	<input type="checkbox"/>	<input type="checkbox"/>	<input type="checkbox"/>	<input type="checkbox"/>

For example, if AL1 is selected, the output will activate if any configured channel reports an AL1 condition. Similarly, if Fault (FLT) is enabled, the output will activate if any channel reports a fault.

Multiple conditions may be enabled, for instance an output may be configured to activate on any alarm and any fault.

9.5.6 Zoned Outputs

To configure an output to monitor a zone, use a Normal cause and effect type, as described below, and associate the channels in the required zone with an output channel.

9.5.7 Input Channel Preselection for Cause and Effect Matrix (Normal Relay Channel)

Access Level: **Engineer**

This screen helps to reduce the number of channels listed in the Cause and Effect (C&E) Matrix to only the channels the operator wants to map. Select the required input channels to link to this relay output channel by checking the box next to the channel ID. The details of this link (Alarm1, Warning...) will be assigned in the next screen.

Note: If you used the option to copy from a configured channel, the input channels linked to that channel will be automatically pre-selected. The alarms, faults etc. associated with these channels may be disabled in the next screen if required.

9.6 Cause & Effect Matrix

The **Cause & Effect matrix** uses a screen similar to that below:

ID/Location	AL1	AL2	AL3	FLT	INH	WRN
Select All	<input type="checkbox"/>	<input type="checkbox"/>	<input type="checkbox"/>	<input type="checkbox"/>	<input type="checkbox"/>	<input type="checkbox"/>
inn <input tag>	<input checked="" type="checkbox"/>	<input type="checkbox"/>	<input type="checkbox"/>	<input type="checkbox"/>	<input type="checkbox"/>	<input type="checkbox"/>
<div style="display: flex; justify-content: space-between; align-items: flex-start;"> <div style="width: 45%;"> <p>At least One Alarm</p> <input type="checkbox"/> Enabled </div> <div style="width: 50%;"> <p>Vote Count 1</p> <p>Channels Selected: 1</p> </div> </div>						

CONFIGURATION

9.6.1 C&E Matrix Explanation

The 'ID/Location' column shows the channels selected in the previous pre-selection screen. If an output is controlled by a single input channel, only one row is shown.

The events that may be selected for each input are shown alongside. Any combination of events may be selected. Any of the selected events will cause the output to activate.

The total number of selected input channels is shown at the bottom of the screen. If an input was selected at pre-selection, but no events are programmed for it, the input is discarded when the configuration is saved.

The **At least One Alarm** and **Vote Count** controls are described in the following sub-chapters.

Note: To remove an unwanted input channel from the cause and effect matrix, for instance from a copied channel, uncheck all the events for that input channel.

9.6.2 STEL, LTEL and Rate Alarms

When an input channel is used for time weighted alarms it is linked to the AL1, AL2 and AL3 events column:

- AL1 is used for STEL
- AL2 is used for LTEL
- AL3 is used for Rate Alarm

The cause and effect matrix is evaluated in the same way as for threshold alarms.

9.6.3 Multiple Inputs

An output may be associated with one or more events per input channel in the cause and effect matrix. When more than one event is associated, voting is used to determine how the output responds to the selected event combination.

9.6.4 Voting

Voting allows a user to select how many input channels must have an active event before an output will change state.

ID/Location	AL1	AL2	AL3	FLT	INH	WRN
Select All	<input type="checkbox"/>	<input type="checkbox"/>	<input type="checkbox"/>	<input type="checkbox"/>	<input type="checkbox"/>	<input type="checkbox"/>
i01 Channel 1	<input checked="" type="checkbox"/>	<input type="checkbox"/>	<input type="checkbox"/>	<input type="checkbox"/>	<input type="checkbox"/>	<input type="checkbox"/>
i02 Channel 2	<input checked="" type="checkbox"/>	<input type="checkbox"/>	<input type="checkbox"/>	<input type="checkbox"/>	<input type="checkbox"/>	<input type="checkbox"/>
i03 Channel 3	<input checked="" type="checkbox"/>	<input type="checkbox"/>	<input type="checkbox"/>	<input checked="" type="checkbox"/>	<input type="checkbox"/>	<input type="checkbox"/>
<div style="display: flex; justify-content: space-between; align-items: flex-start;"> <div style="width: 45%;"> <p>At least One Alarm</p> <p><input type="checkbox"/> Enabled</p> </div> <div style="width: 50%;"> <p>Vote Count 2</p> <p>Channels Selected: 3</p> </div> </div>						

In the example above, an output is associated with three input channels in the cause and effect matrix. The vote count is set to two. The output will activate if at least two of the three input channels have an active event.

CONFIGURATION

For example:

Condition 1	Condition 2	Condition 3	Output State
Channel 1 A1	Channel 2 A1	—	Activated
Channel 1 A1	Channel 3 A1	—	Activated
Channel 1 A1	Channel 2 A1	Channel 3 A1	Activated
Channel 1 A1	Channel 3 Fault	—	Activated
Channel 2 A1	Channel 3 A1 and Fault	—	Activated
Channel 3 A1	Channel 3 Fault	—	Not Activated

In the example, if the vote count is set to 1, any one or more input channels with an active event will cause the output to activate. Similarly, if the vote count is set to 3, each input must have at least one active event to cause the output to activate.

9.6.5 Vote Compensation (Vote Reduction)

If a voting input is inhibited or has a fault, it can prevent a voted output from activating as expected. Vote compensation may be used to take account of failing or inhibited inputs.

ID/Location	AL1	AL2	AL3	FLT	INH	WRN
Select All	<input type="checkbox"/>	<input type="checkbox"/>	<input type="checkbox"/>	<input type="checkbox"/>	<input type="checkbox"/>	<input type="checkbox"/>
i01 Channel 1	<input checked="" type="checkbox"/>	<input type="checkbox"/>	<input type="checkbox"/>	<input type="checkbox"/>	<input type="checkbox"/>	<input type="checkbox"/>
i02 Channel 2	<input checked="" type="checkbox"/>	<input type="checkbox"/>	<input type="checkbox"/>	<input type="checkbox"/>	<input type="checkbox"/>	<input type="checkbox"/>
i03 Channel 3	<input checked="" type="checkbox"/>	<input type="checkbox"/>	<input type="checkbox"/>	<input type="checkbox"/>	<input type="checkbox"/>	<input type="checkbox"/>
i04 Channel 4	<input checked="" type="checkbox"/>	<input type="checkbox"/>	<input type="checkbox"/>	<input type="checkbox"/>	<input type="checkbox"/>	<input type="checkbox"/>
<div style="display: flex; justify-content: space-between; align-items: flex-start;"> <div style="width: 45%;"> <p>At least One Alarm</p> <p><input type="checkbox"/> Enabled</p> </div> <div style="width: 50%;"> <p>Vote Count 3</p> <p>Channels Selected: 4</p> </div> </div>						

In the example above, 3 inputs are required to be in an alarm state to activate the output. If, for instance, two inputs are in a fault or inhibit state, only two inputs are able to vote. The output cannot activate, even if both remaining inputs alarm:

Channel 1	Channel 2	Channel 3	Channel 4	Count	Output State
AL1	AL1	AL1	Don't care	3	Activated
Fault	AL1	AL1	AL1	3	Activated
Fault	AL1	Inhibit	AL1	2	Not Activated

CONFIGURATION

TPPR allows the fault and inhibit conditions to be included in the vote, simply by checking the options for those inputs.

ID/Location	AL1	AL2	AL3	FLT	INH	WRN
Select All	<input type="checkbox"/>	<input type="checkbox"/>	<input type="checkbox"/>	<input type="checkbox"/>	<input type="checkbox"/>	<input type="checkbox"/>
i01 Channel 1	<input checked="" type="checkbox"/>	<input type="checkbox"/>	<input type="checkbox"/>	<input checked="" type="checkbox"/>	<input type="checkbox"/>	<input type="checkbox"/>
i02 Channel 2	<input checked="" type="checkbox"/>	<input type="checkbox"/>	<input type="checkbox"/>	<input checked="" type="checkbox"/>	<input type="checkbox"/>	<input type="checkbox"/>
i03 Channel 3	<input checked="" type="checkbox"/>	<input type="checkbox"/>	<input type="checkbox"/>	<input checked="" type="checkbox"/>	<input checked="" type="checkbox"/>	<input type="checkbox"/>
i04 Channel 4	<input checked="" type="checkbox"/>	<input type="checkbox"/>	<input type="checkbox"/>	<input checked="" type="checkbox"/>	<input type="checkbox"/>	<input type="checkbox"/>
At least One Alarm						
<input type="checkbox"/> Enabled			Vote Count 3 Channels Selected: 4			

Then the output may be activated as follows:

Channel 1	Channel 2	Channel 3	Channel 4	Count	Output State
AL1	AL1	AL1	Don't care	3	Activated
Fault	AL1	AL1	AL1	4	Activated
Fault	AL1	Inhibit	AL1	4	Activated
Inhibit	AL1	AL1	Normal	2	Not Activated

9.6.6 Requiring At Least One Alarm

When faults and inhibit conditions are included in the cause and effect logic, it may be possible to activate an output with **Fault** and **Inhibits** only. Using the above cause and effect example:

Channel 1	Channel 2	Channel 3	Channel 4	Count	Output State
Fault	Fault	Fault	Don't care	3	Activated
Fault	Don't care	Inhibit	Fault	3	Activated
Normal	Fault	Inhibit	Fault	3	Activated

CONFIGURATION

It is possible to avoid this situation and require at least one real alarm condition to be present before the output activates. Check the 'At least One Alarm' checkbox:

ID/Location	AL1	AL2	AL3	FLT	INH	WRN
Select All	<input type="checkbox"/>	<input type="checkbox"/>	<input type="checkbox"/>	<input type="checkbox"/>	<input type="checkbox"/>	<input type="checkbox"/>
i01 Channel 1	<input checked="" type="checkbox"/>	<input type="checkbox"/>	<input type="checkbox"/>	<input checked="" type="checkbox"/>	<input type="checkbox"/>	<input type="checkbox"/>
i02 Channel 2	<input checked="" type="checkbox"/>	<input type="checkbox"/>	<input type="checkbox"/>	<input type="checkbox"/>	<input type="checkbox"/>	<input type="checkbox"/>
i03 Channel 3	<input type="checkbox"/>	<input type="checkbox"/>	<input type="checkbox"/>	<input checked="" type="checkbox"/>	<input checked="" type="checkbox"/>	<input type="checkbox"/>
i04 Channel 4	<input type="checkbox"/>	<input type="checkbox"/>	<input type="checkbox"/>	<input checked="" type="checkbox"/>	<input type="checkbox"/>	<input type="checkbox"/>
At least One Alarm						
<input checked="" type="checkbox"/> Enabled				Vote Count 3 Channels Selected: 4		

The output will not activate unless one or more input channels indicate an alarm, as shown in the examples below:

Condition	Channel 1	Channel 2	Channel 3	Channel 4	Count	Output State
1	Fault	Fault	Fault	Don't care	3	Not Activated
2	Fault	Normal	Inhibit	Fault	3	Not Activated
3	Fault	AL1	Inhibit	Normal	3	Activated
4	AL1	AL1	Inhibit	Fault	4	Activated

9.6.7 Controller Display and LEDs

The cause and effect matrix controls the state of programmed outputs. Alarms, faults and warnings are reported independently on the controller front panel and are not affected by cause and effect settings.

9.6.8 Alarm Update

Alarm Update is used to indicate that one or more alarm events included in a cause and effect matrix has occurred since any previous events were acknowledged.

For instance:

1. A sensor detects that an AL1 threshold has been exceeded
2. The operator accepts the AL1 alarm
3. The sensor detects that the gas level has risen and the AL2 threshold has been exceeded
4. The system must indicate that a change has occurred.

Or:

1. A sensor in a voting group indicates an alarm
2. The operator accepts the alarm
3. A further sensor indicates an alarm
4. The system must indicate that a change has occurred.

CONFIGURATION

The alarm update responds to events associated with an output by a cause and effect relationship. If an event occurs but is not included in the cause and effect logic, the controller will respond normally and indicate the event but the Alarm Update will not respond to it.

For instance, if AL1 and AL2 of an input channel are configured in a cause and effect matrix, but AL3 is not:

1. The signal exceeds the AL1 level – alarm update responds to the event; The operator accepts the alarm
2. The signal exceeds the AL2 level – alarm update responds to the event; The operator accepts the alarm
3. The signal exceeds the AL3 level – the event is still reported on the controller but alarm update does not respond

Note on Rising and Falling Levels

Alarm Update responds to events in increasing order of severity, for instance rising gas levels on a toxic or flammable sensor. **Alarm Update** does not respond to a gas level changing to a less severe condition.

Event	Result
Signal exceeds alarm level	Alarm update responds, output activates
User Accepts event	Alarm update responds, according to configuration
Signal level falls below alarm level	Alarm update does not respond
User Resets event	Output deactivates

9.6.9 Action on Events

The output action on a new event may be set to **Steady** or **Pulsing**. The pulsing output may, for instance, be used to directly control a flashing lamp.

The Pulsing option is only available when the alarm update function is enabled.

9.6.10 Action on New Event – Steady

The output channel operation is as follows:

Condition or action	Output state
An alarm event occurs	The output activates.
Operator presses Accept	The output deactivates.
A further event occurs	The output activates again
Operator presses Accept	The output deactivates.
And so on...	

9.6.11 Action on New Event – Pulsing

The output channel operation is as follows:

Condition or action	Output state
An alarm event occurs	The output activates - pulsing
Operator presses Accept	The output is activated but steady
A further event occurs	The output is activated but pulses
Operator presses Accept	The output is activated but steady
And so on...	

9.6.12 Operation of Reset

Reset operates normally: e.g. if the alarm condition is still active, the alarm(s) cannot be reset and a warning is displayed. The alarm may be reset when the alarm condition is cleared.

9.6.13 Notes on Use

An output configured for **Alarm Update** does not indicate the alarm status; instead it indicates that one or more events have not been acknowledged or that a new (unacknowledged) event has occurred. The output will silence when all contributing alarms are acknowledged.

CONFIGURATION

Where it is required to remotely indicate the alarm status, a second output channel should also be configured. **Alarm Update** should not be enabled for this channel.

The output will not deactivate when acknowledged, and will remain activated until reset.

9.6.14 Typical applications

- **Pulsed Relay on Activation** (usually flashes a Lamp) and goes 'Steady' on accept (non-flashing lamp): Starts 'Pulsing' if a further activation is seen.
- **Steady Relay on Activation** (usually starts Siren) and goes 'OFF' on accept (silent): Starts 'Steady' if further activation is seen.

9.7 Control of Output Channels – Priority

Output channels can be controlled via various options. In addition to the state of inputs and the cause and effect matrix, the output may be inhibited or forced to a specific state.

The control inputs are evaluated as shown below. Inputs to the right will override inputs to their left, e.g. **Output Inhibit** will override the input state, C&E logic and the alarm update settings but will be overridden by an **Output Force** condition.

Ascending Priority Order	1	2	3	4	5	6
	Input State	C&E Logic	Alarm Update	Output Inhibit	Output Force	Final Output

9.8 Power Supply Unit Parameters

Four **Power Supply Unit** inputs are accessible from the System Setup screen. They are provided to monitor and report the status of power supply unit status relays. The input status is reported on the controller, and may be selected as Alarm, Fault or Warning. These inputs may not be assigned to a relay output but will activate Fault or Warning Master outputs.

The PSU inputs are not shown on the Inputs screen. They may be Acknowledged and Reset but not Inhibited.

If not required for this purpose they may be configured to act as global Acknowledge, Reset or Inhibit inputs.

Refer to section 5.3.3 for connection details.

9.8.1 Commission PSU

Access Level: **Engineer**

Parameter Name	Default Setting	Value Range	Comment
Power Supply Unit Tag	'PSU<x> Alarm' where <x> is 1 to 4.	Maximum 30 Alphanumeric Characters	30 character location tag name. This is the main channel description used throughout the interface
Channel Type	'Normal PSU'	Normal PSU Ack Global Reset Global Inhibit Global	Signals PSU status. When one of the Global Input modes is selected a remote switch can be used to activate the desired function.

9.8.2 Power Supply Unit Screen 2

Access Level: **Engineer**

Parameter Name	Default Setting	Value Range	Comment
Input Function	Alarm	Alarm Fault Warning	When configured as a Global Input the Input Function is fixed as 'Remote Interaction'.
Default State	Normally Open (NO)	Normally Open (NO) Normally Closed (NC)	State for quiescent operation, PSUs OK or no input action selected
Input Latch	Latching	Non-Latching Latching	When configured as a Global Input the Input Latch is fixed as Latching

CONFIGURATION

10 Configuring STEL and LTEL Alarms

TPPR mA channels may be configured as STEL and LTEL alarms. The same channel may be used for both STEL and LTEL.

STEL and LTEL are always rising alarms, and are latched by default.

Note: STEL and LTEL Alarms should always be set to Latching. A non-latching alarm may reset before the appropriate actions can be taken.

A channel programmed for STEL and/or LTEL may not be used for threshold alarms (A1, A2, and A3). When connected to an output cause and effect matrix, STEL replaces A1, LTEL replaces A2, and the rate alarm replaces A3.

In common with other alarms, STEL and LTEL alarms cannot be reset if an Over Range Warning is active. The Over Range Warning must be cleared first.



WARNING

STEL AND LTEL HISTORY IS RESET WHEN POWER IS REMOVED. THE READING WILL REQUIRE AN INITIALIZATION TIME AFTER POWER IS RESTORED.

10.1 STEL Operation

The controller takes four gas readings every second. Readings are rolled up and averaged over the configured STEL interval.

The averaged STEL value is updated every half minute and compared against the programmed STEL limit.

The STEL alarm is activated if the calculated result is above the programmed threshold.

The average is calculated continuously while the system is powered.

The averaged value is initialised to a default value:

- when power is applied
- when there is a change in STEL configuration
- when the alarm is reset by a user

The default value is equal to the Gas Range Minimum configured for the channel. Following initialisation, the calculation requires one STEL interval to stabilise.

When the channel is inhibited, the controller continues to calculate the average but uses the above default value instead of the sensor value. The channel will not alarm while inhibited.

The alarm cannot be reset until the averaged value falls below the programmed threshold. The time to wait before you can reset will depend upon the degree of ventilation, the residual gas levels and the programmed settings.

Note: The STEL Interval is configurable from 5 – 20 minutes in 5 min. increments, from 20 – 40 minutes in 10 min. increments and finally to 60 minutes.

CONFIGURATION

10.1.1 STEL Algorithm

TPPR calculates the moving half-minute time-weighted average (HM_TWA) of the selected STEL time interval as:

$$\text{STEL} = (\text{HM_TWA1} + \text{HM_TWA2} + \text{HM_TWA3} \rightarrow + \text{HM_TWA}_N) / \text{STELN}$$

Where:

- HM_TWA1 = 1st Half Minute TWA
- HM_TWA2 = 2nd Half Minute TWA
- HM_TWA_N = Nth Half Minute TWA
- STELN – Number of Half Minute TWA Samples received in the chosen STEL interval (1a – 1g above)

The CCB then uses the resulting half-minute TWA for STEL moving average calculations:

$$\text{HM_TWA} = (\text{GC1} + \text{GC2} + \text{GC3} \rightarrow + \text{GC}_N) / N$$

Where:

- HM_TWA = Half Minute TWA
- GC1 = 1st Gas Concentration Sample
- GC2 = 2nd Gas Concentration Sample
- GC_N = Nth Gas Concentration Sample
- N = Number of Samples received in half Minute

10.2 LTEL Operation

The controller takes four gas readings every second. Readings are rolled up and averaged over the LTEL interval, which is fixed at 8 hours.

The averaged LTEL value is updated every ten minutes and compared against the programmed LTEL limit.

The LTEL alarm is activated if the calculated result is above the programmed threshold.

Once started, the average is calculated continuously while the system is powered.

The averaged value is initialised to a default value:

- when power is applied
- when there is a change in LTEL configuration
- when the alarm is reset by a user

The default value is equal to the Gas Range (Min) configured for the channel.

When the channel is inhibited, the controller continues to calculate the average but uses the above default value instead of the sensor value. The channel will not alarm while inhibited.

The alarm cannot be reset until the current gas level reported by the sensor is below the programmed LTEL alarm level. The time to wait before you can reset will depend upon the degree of ventilation and the residual gas levels.



WARNING

STEL AND LTEL HISTORY IS RESET WHEN POWER IS REMOVED. THE READING WILL REQUIRE AN INITIALIZATION TIME AFTER POWER IS RESTORED.

CONFIGURATION

10.2.1 TWA Start of First Shift Time

This setting is not used by the LTEL calculation and does not need to be changed.

10.2.2 LTEL Algorithm

The CCB will calculate the moving average of the LTEL for an 8-hour time interval.

$$\text{LTEL} = (\text{TEN_MIN_TWA1} + \text{TEN_MIN_TWA2} + \dots + \text{TEN_MIN_TWAN}) / \text{LTELN}$$

Where:

- LTEL = Long Term Exposure Limit TWA
- TEN_MIN_TWA1 = 1st Ten-Minute TWA
- TEN_MIN_TWA2 = 2nd Ten-Minute TWA
- TEN_MIN_TWAN = Nth Ten-Minute TWA
- LTELN = Number of Ten-Minute TWA Samples received in 8 hours

CCB will use the Ten-Minute TWA for LTEL moving average calculations:

$$\text{TEN_MIN_TWA} = (\text{HM_TWA1} + \text{HM_TWA2} + \dots + \text{HM_TWAN}) / \text{TEN_MINN}$$

Where:

- TEN_MIN_TWA = Ten-Minute TWA
- HM_TWA1 = 1st Half-Minute TWA
- HM_TWA2 = 2nd Half-Minute TWA
- HM_TWAN = Nth Half-Minute TWA

The CCB will add the 'Half-Minute TWA' samples received in 10 minutes and then divide it by the TEN_MINN to calculate the 'Ten-Minute TWA'.

Every half minute the CCB updates LTEL TWA by discarding HM_TWA1 and adding the latest HM_TWAN.

Every 10 minutes the CCB recalculates the LTEL TEN_MIN_TWA and divides it by 'TEN_MINN' to give a new reading.

CONFIGURATION

10.2.3 LTEL Reset

LTEL alarms can be manually reset when the alarm is still active (force reset) but only when the ambient gas value is less than LTEL alarm level and with no Gas-Over-Range warnings on the system.

10.2.4 Resolution and Reporting

Resolution for STEL is 0.5 Minutes. Alarm reporting may be delayed by up to 30 seconds of the configured interval. STEL Alarm may report earlier than the configured interval based on the Gas Concentration value over the period and the configured 'STEL Alarm Level'.

Resolution for LTEL is 10 Minutes. Alarm reporting may be delayed by 10 minutes. LTEL Alarm may report earlier than the 8 Hours based on the Gas Concentration value over the period and the configured 'LTEL Alarm Level'.

10.2.5 STEL and LTEL Evaluation During Channel Inhibit

During Channel Inhibit state, the CCB sets the 'Gas Concentration Value' to the programmed Gas Range (min) for evaluation of STEL and LTEL TWA, but it does not evaluate the STEL and LTEL Alarms.

10.2.6 STEL and LTEL Evaluation During Channel Fault

STEL and LTEL faults can be further divided into two sub-categories:

1. Fault conditions, in which the CCB knows the Gas Concentration Value; i.e. Signal Under Range / Signal Over Range.
In this state CCB continues to calculate the Time Weighted Averages.
2. Fault conditions, in which the CCB does not know the Gas Concentration Value; i.e. Module Ring Communication Error, Channel Open / Short / Diagnosis Error.
During this Channel Fault state, the CCB will set the Gas Concentration Value to the programmed Gas Range (min) for evaluation of STEL and LTEL TWA.

10.2.7 Further Information

For further information please read **EN 45544-4**, which gives guidance on workplace atmospheres; electrical apparatus used for the direct detection and direct concentration measurement of *toxic gases and vapours*; guide for selection, installation, use and maintenance.

CONFIGURATION

11 Configuring Modbus

Refer to the documentation supplied with the host computer for details of its communication and Modbus configuration.

Note: It is recommended that the host computer is configured to provide at least two retries in the event of a communication loss with a minimum delay of 1 s between each poll, and a minimum timeout of 2 s.

Note: TPRR Modbus automatically uses two stop bits when parity is “None” and one stop bit when parity is “Odd” or “Even”.

To configure the TPRR Modbus communication parameters:

1. Login as an **Engineer**.
2. From the System Status screen select the Tool Box icon then Global Settings.
3. Select **Modbus Settings> Edit** to adjust the parameters.
4. When complete, select **Save** and exit settings.

Parameter Name	Default Setting	Value Range	Comment
Baud Rate	9600	9600, 19200	Should be set to correspond to the baud rate of the host system.
Parity	None	Even, Odd, None	Should be set to correspond to the parity checking set on the host system.
Primary Slave Address	1	1 to 247	Each node connected to the RS485 highway must have a different address setting in daisy chain or multi-drop configuration.
Secondary Slave Address	2	1 to 247	

Table 17. Modbus Parameter Settings

11.1 Modbus Register Allocation for Function 02 – Read Input Status

This function reads the input channel status bits. Each status bit can have the value 1 = Active or 0 = Not active. For the Channel Type only, 1 = Analogue or 0 = Digital. There are twelve status bits for each channel. The maximum number of status bits read in one frame is 512.

Channel	Rate Alarm	LTEL Alarm	STEL Alarm	Alarm 3	Alarm 2	Alarm 1	Inhibit	Fault	No Data	Channel Type	Not Used	SIL Channel (Future Use)	Safe State (Future Use)	Warning	Acknowledged	Not Used
01	10001	10002	10003	10004	10005	10006	10007	10008	10009	10010	10011	10012	10013	10014	10015	10016
02	10017	10018	10019	10020	10021	10022	10023	10024	10025	10026	10027	10028	10029	10030	10031	10032
↓	↓	↓	↓	↓	↓	↓	↓	↓	↓	↓	↓	↓	↓	↓	↓	↓
64	11009	11010	11011	11012	11013	11014	11015	11016	11017	11018	11019	11020	11021	11022	11023	11024

Table 18. Modbus Input Channels

Channel	Rate Alarm (Not used)	LTEL Alarm (Not used)	STEL Alarm (Not used)	Alarm 3 (Not used)	Alarm 2 (Not used)	Alarm 1	Inhibit	Fault	No Data	Channel Type (Not used)	Force State	SIL Channel (Future Use)	Safe State (Future Use)	Warning	Acknowledged	Free
5	11073	11074	11075	11076	11077	11078	11079	11080	11081	11082	11083	11084	11085	11086	11087	11088
02	11089	11090	11091	11092	11093	11094	11095	11096	11097	11098	11099	11100	11101	11102	11103	11104
↓	↓	↓	↓	↓	↓	↓	↓	↓	↓	↓	↓	↓	↓	↓	↓	↓
128	13105	13106	13107	13108	13109	13110	13111	13112	13113	13114	13115	13116	13117	13118	13119	13120

Table 19. Modbus Output Channels

CONFIGURATION

	Rate Alarm Summary	LEL Alarm Summary	STEL Alarm Summary	Alarm 3 Summary	Alarm 2 Summary	Alarm 1 Summary	Inhibit Summary	Fault Summary	Not Used	Not Used	Not Used	Not Used	Not Used	Not Used	Not Used	Not Used
System Summary	11025	11026	11027	11028	11029	11030	11031	11032	11033	11034	11035	11036	11037	11038	11039	11040

Table 20. Modbus System Summary

	Not Used	Not Used	Not Used	Not Used	Not Used	Not Used	Not Used	Not Used	Not Used	Not Used	Not Used	Not Used	Not Used	Not Used	Not Used	Not Used
System Summary	11041	11042	11043	11044	11045	11046	11047	11048	11049	11050	11051	11052	11053	11054	11055	11056

Table 21. Modbus System Summary Continued

	Safe State Summary (Future Use)	Warning Summary	Not Used	Not Used	Not Used	Not Used	Not Used	Not Used	Not Used	Not Used	Not Used	Not Used	Not Used	Not Used	Not Used	Not Used
System Summary	11057	11058	11059	11060	11061	11062	11063	11064	11065	11066	11067	11068	11069	11070	11071	11072

Table 22. Modbus System Summary Continued

11.2 Modbus Register Allocation for Function 04 – Read Input Registers

There are three sets of input registers for each channel:

1. The analogue signal expressed as a 16 bit signed integer value.
2. The analogue signal expressed as a 32 bit floating point value.
3. An animation value.

11.2.1 Analogue Registers (Integer)

This register contains the indicated measured value in steps of 0.1 measurement units (e.g. PPM, LEL). This register should not be used on channels where the parameter "Gas Range Max" is set to values greater than 1000.

Channel	Analogue Value (Integer)
01	30001
02	30002
↓	↓
64	30064

Table 23. Modbus Channel Analogue Values

Note: The Integer format is a 16 bit signed integer.

11.2.2 Analogue Registers (Float)

Channel	Analogue Value (Float) Register 1	Analogue Value (Float) Register 2
01	30129	30130
02	30131	30132
↓	↓	↓
64	30255	30256

Table 24. Modbus Channel Analogue Values (Float)

Note: The Float format is a 32 bit floating point value in accordance with IEEE 754-2008.

CONFIGURATION

11.2.3 Animation Registers

A group of animation values are allocated for registers 30065 to 30128. These are intended to be used by graphics packages for defining the colours of various screen objects based upon the status of a channel.

A 16 bit unsigned word format is used.

Channel	Animation Register
01	30065
02	30066
↓	↓
64	30128

Table 25. Modbus Channel Animation Register

The data value for each register can be one of the following:

Value	Status
0	Channel operating normally
1	RATE alarm active
2	LTEL alarm active
3	STEL alarm active
4	A1 alarm active
5	A2 alarm active
6	A3 alarm active
7	Fault active
8	Inhibit active
9	Not used
10	Not used
11 or higher	No data available

Table 26. Modbus Channel Animation Register Continued

11.3 Register Allocation for Function 03 / 06 / 16 – Read / Write Holding Registers

All registers use 16 bit data words.

The Channel Type field identifies the channel as Input or Output. The decimal value 105 (= ASCII 'i') is used for Inputs, the decimal value 111 (= ASCII 'o') for Outputs. The decimal value 6 together with channel ID 0 is used for master commands. Function 16 can be used to write to the 40n01 to 40n04 and 41n01 to 41n05 (n = 0 to 9) ranges of registers only.

Caution: When using Function 6 or Function 16, ensure that the registers related to the command are completely filled before setting the Block Active flag; otherwise an unintended command may be performed.

11.3.1 Query Poll Registers

Query Poll Block	Block Active	Channel Type	Channel ID	Query Type	Result	Result String
1	40001	40002	40003	40004	40005	40006 to 40036
2	40101	40102	40103	40104	40105	40106 to 40136
3	40201	40202	40203	40204	40205	40206 to 40236
4	40301	40302	40303	40304	40305	40306 to 40336
5	40401	40402	40403	40404	40405	40406 to 40436

CONFIGURATION

6	40501	40502	40503	40504	40505	40506 to 40536
7	40601	40602	40603	40604	40605	40606 to 40636
8	40701	40702	40703	40704	40705	40706 to 40736
9	40801	40802	40803	40804	40805	40806 to 40836
10	40901	40902	40903	40904	40905	40906 to 40936

Table 27. Query Poll Register

Allowed values for the Result register 40n05 (n = 0 to 9):

Value	Meaning
0	Success
1	Command not permitted
2	Inter process communication failure
67	Failure

Table 28. Query Poll Register Values

11.3.2 Query Poll Descriptions

Poll No	Description	Response Format
02	Read System Label	B
39	Read Alarm 1 level	A
40	Read Alarm 2 level	A
41	Read Alarm 3 level	A
42	Read STEL level	A
43	Read LTEL level	A
44	Read Rate level	A
102	Read Gas Name	B
103	Read Channel Tag Name	B
104	Read Gas Unit	B

Table 29. Query Poll Descriptions

Response formats for the Result String registers 40n06 - 40n36 (n = 0 to 9):

Type	Format
A	Float (4 Bytes – 32 bit floating point)
B	Unicode String – 35 (Unicode chars) + 1(null)

Table 30. Query Poll Types

Example: Read Alarm 1 level (Query Type):

Register	Block Active (40n01)	Channel Type (40n02)	Channel ID (40n03)	Query Type (40n04)	Result (40n05)	Result String (40n06 to 40n36)

CONFIGURATION

Value	1	105	2	39	(Updated upon request execution)	(Updated upon request execution)
--------------	---	-----	---	----	----------------------------------	----------------------------------

Table 31. Query Poll Example

If Block Active is set to 1, the Controller processes the request. If Block Active is set to 0 the Controller will not process the request or has already processed the request.

The options for Channel Type are 105 – Input Channel and 111 – Output Channel.

11.3.3 Command Poll Registers

Command Poll Block	Block Active	Channel Type	Channel ID	Command Type	Command Data	Result
1	41001	41002	41003	41004	41005	41006
2	41101	41102	41103	41104	41105	41106
3	41201	41202	41203	41204	41205	41206
4	41301	41302	41303	41304	41305	41306
5	41401	41402	41403	41404	41405	41406
6	41501	41502	41503	41504	41505	41506
7	41601	41602	41603	41604	41605	41606
8	41701	41702	41703	41704	41705	41706
9	41801	41802	41803	41804	41805	41806
10	41901	41902	41903	41904	41905	41906

Table 32. Command Poll Registers

Allowed values for the Result register 41n05 (n = 0 to 9):

Value	Meaning
0	Success
1	Command not permitted
2	Inter process communication failure
67	Failure

Table 33. Command Poll Register Values

11.4 Command Types

Note: Function 06 cannot be used for SIL channels.

Command Type	Description
23	Alarm Acknowledge
24	Alarm Reset
25	Set Inhibit
26	Clear inhibit

Table 34. Command Types

CONFIGURATION

Example: Alarm Acknowledge (Command Type):

Register	Block Active (41n01)	Channel Type (41n02)	Channel ID (41n03)	Command Type (41n04)	Command Data (41n05)	Result (41n06)
Value	1	105	2	23	0	(Updated upon request execution)

Table 35. Command Type Example

If Block Active is set to 1, the Controller processes the request, but if Block Active is set to 0 the Controller will not process the request or has already processed the request.

The options for Channel Type are 105 – Input Channel, 111 – Output Channel and 6 – Global (all channels).

If the Command Data is set to 0, the command will apply to all the channel alarms if a specific channel is identified or to all channels if the channel type is Global.

11.5 Exception Responses

The Modbus exception response is detailed in the Modicon Modbus manual. Any one of the following exception responses may be returned by the Touchpoint Pro Modbus interface:

Exception	Description
01 ILLEGAL FUNCTION	Only Modbus functions 02, 03, 04 and 06 are supported. This response is returned if any other requests are received.
02 ILLEGAL DATA ADDRESS	The register addresses supported by each function are listed in this chapter. Any attempt to access a register outside of these ranges will result in this error.
03 ILLEGAL DATA VALUE	This exception is returned if the request has the incorrect length, or if the maximum number of registers is exceeded. The maximum number of registers that can be requested by function 02 is 512, function 04 is 64, and function 03 is 36 for the Query poll block or 6 for the Command poll block.
06 SLAVE DEVICE BUSY	Applies to function 06 only. Once a poll or command block's active register has been set, its contents must not be changed until the main program has carried out the request. This exception is returned if any attempt is made to change an active poll or command block.

Table 36. Modbus Exception Responses

Note: A function 06 that leaves the block unchanged will not generate this error.

CONFIGURATION

12 Configuration Files

12.1 Viewing and Editing the Configuration

TPPR systems are normally configured to the customer's requirements on manufacture, but you can view and edit the configuration if required.

Note: Only Honeywell trained and authorised persons should edit settings as errors can adversely affect system functions.

A configuration timeout is activated when you enter the **System Setup** menu and you will be logged out of configuration if no values are sent to the system for 20 minutes. Any changes that have already been sent to the system will be retained, but any that have been made but not yet sent to the system will be lost. It may be necessary to login and return to **System Setup** and set the module to **Normal State** before retrying the edits.

12.1.1 To View or Edit the Configuration:

1. Login as an **Administrator** or **Engineer**.
2. From the **System Status** screen select the **Extras** icon then **System Configuration**.
3. Re-enter the password and select **Login**.
4. Select **System Setup**.
5. Select the required module, and then click the **Menu** icon.
6. Select **Edit Configuration** and then follow the on-screen menus.
7. The screen will show the system setup tree listing all installed I/O modules and Control Centre Board(s).
8. Select the + beside each module to expand and show its four channels.
9. Select the required channel, select the **Menu** icon and select **Edit Configuration**.
10. Select the screen that you want to edit (refer to the previous sections).
11. Enter the required **New Value** and select **Send**.
12. The system will show the new values; select **Accept**.
13. Either edit another channel or **Log out**.

You should back up the TPPR system configuration once commissioning is completed, and again after any changes to the setup or software. The TPPR safety system remains operational during this procedure but the controller touch screen, PC Configuration software and Webserver may not be used.

The configuration may be backed up to SD card or USB drive. Backups are stored to a dedicated folder on the SD card or USB drive. Backup files are allocated a sequential number to allow the latest backup to be identified.

The sequence number is determined by examining the files already present in the backup's directory. If more than one storage device is used, the same number may be used on each device. A consistent backup regime should be used to prevent data loss or confusion.

If backing up to SD card, the installed event logging SD card is normally used. This card may be briefly removed to copy the backup file to a PC but the card should be refitted as soon as possible to avoid data loss.

It is possible to back up to a replacement SD card but any events that occur during the backup process will be logged to this SD card and will not be available in the event history when the card is removed.

Note: **Engineer** access level is required to back up the configuration. **Administrator** access level is required to restore configuration.

CONFIGURATION

12.2 To Back Up the Configuration

1. Ensure that the **destination drive** is inserted in the **Control Module**.
2. Login as an **Engineer**.
3. From the System Status screen select the Tool Box icon then System Configuration then System Management.
4. Re-enter the password and select **Login**.
5. Select CCB Management and click on Configuration Backup:
6. Select the required drive.
7. The system will display a message 'The configuration backup process might take a few minutes. The User Interface is not accessible during this time. Do you want to proceed?' Ensure that destination drive is always connected during this operation.
8. Once the action is confirmed, the configuration backup process starts and a progress message is displayed. The backup may take several minutes depending on the system size.
9. The Configuration backup file is stored on the memory device in:

TPPR Configuration\TPPR_Config_SystemID_<sequence>.bin
 e.g.: TPPR_Config_SYSTEMSPL0003_009.bin

12.3 Restoring the Configuration

The **CCB** remains operational during a **System Restore** and may initiate unwanted actions (see **CAUTION** below).

Note: The user interface is not available until the entire restore process, including power cycling, is complete. In addition a Restore will not work if a module is in a Fault state so all faults must be rectified first.

Note: A backup *may* be restored if the *CCB* UDID is different from the *CCB* UDID in the backup file, but *not* when the *module* UDIDs present in the system are different to the *module* UDIDs recorded in the backup file.

A pop-up confirms the changes have been made.



CAUTION

Disconnect all TPPR outputs before restoring the configuration as it may cause unwanted activation of beacons, sounders or relay operated devices.
 Calibration data is lost during a system restore so you must recalibrate your sensors following the restore.

12.3.1 To Restore the Configuration

1. Ensure that the system is working correctly with no ring or module faults present.
2. Ensure that the SD card or USB drive containing the required backup file is installed.
3. Login as an **Administrator**.
4. From the **System Status** screen select the **Tool Box** icon... 
5. ...then System Configuration>System Management.
6. Re-enter the password and select **Login**.
7. Select CCB Management and click on Configuration Restore:
8. Select your restore point from the list and click **OK**.

The system will display a message identifying that the present system configuration will be overwritten, and will ask if you want to continue.

Once the action is confirmed, the configuration restoration process starts and a progress message is displayed. The process may take several minutes depending on the system size.

You should generate a configuration report to verify the settings once the configuration is restored.

You should recalibrate your sensors if required (see *Ch.8 Calibrating Gas Sensors*).

CONFIGURATION

12.4 Deleting the Configuration

The **Administrator** has the option to delete the system configuration. This option is for specific circumstances only, and is not intended for normal use.

Before deleting the system configuration, ensure that a known working backup file is available; otherwise it will be necessary to re-configure the system.

Note: At least one Ring circuit must be functioning in order to delete a configuration.



CAUTION

Following configuration deletion, the IO modules revert to their unconfigured state and the CCB must be power-cycled. It will then be necessary to re-initialise the ring, reconfigure the modules (or restore them from backup) and recalibrate all catalytic sensors.

Disconnect all outputs before deleting the configuration as it may cause unwanted activation of beacons, sounders or relay operated devices.

12.4.1 To Delete the Configuration

1. Login as an **Administrator**.
2. From the System Status screen select the Tool Box icon then System Configuration then System Management.
3. Re-enter the password and select **Login**.
4. Select System Management>CCB Management>Configuration Delete: 
5. The system will display warning messages (Fig. 32 below).
6. Select **Yes** to delete or **No** to exit without changing anything.
7. When **Yes** is selected the configuration deletion process starts and progress messages are displayed. The deletion process may take several minutes depending on the number of modules and sensors installed.
8. Cycle the power off and on when instructed (Fig. 31-3).
9. Login again and restore the required configuration from a backup as shown above. Alternatively reconfigure the system as shown in this *Commissioning* section.
10. Once the configuration is restored you should generate a configuration report to verify the settings and then back up the new settings, and then recalibrate your sensors if required (next chapter).

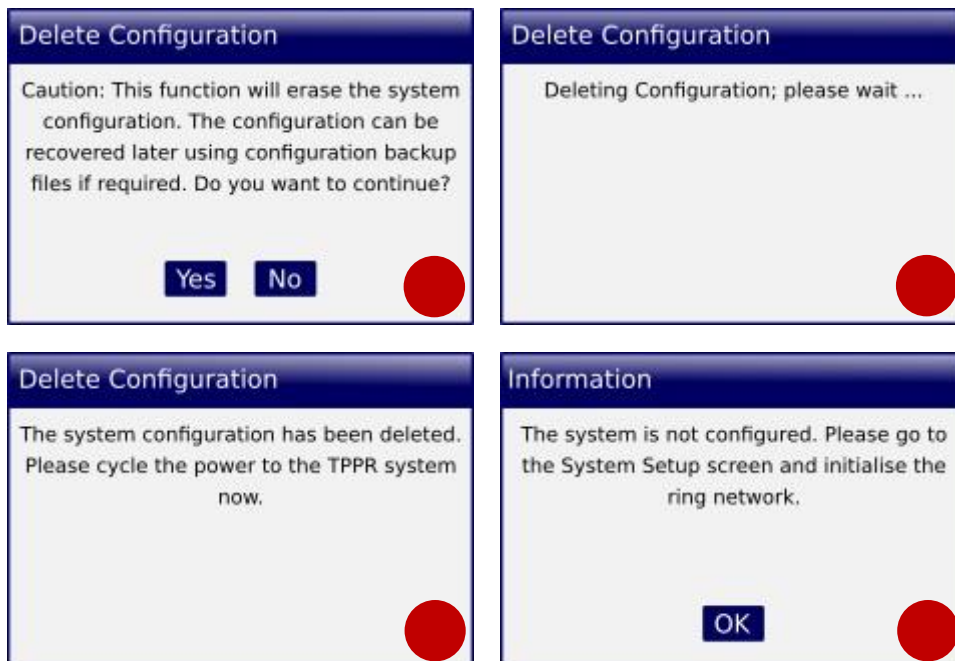

Figure 80. Delete Configuration Screenshots

CONFIGURATION

12.5 CCB Configuration Settings

To access the CCB configuration settings, log in as Administrator and navigate to **Tool Box>System Configuration>System Management>CCB Configuration**:

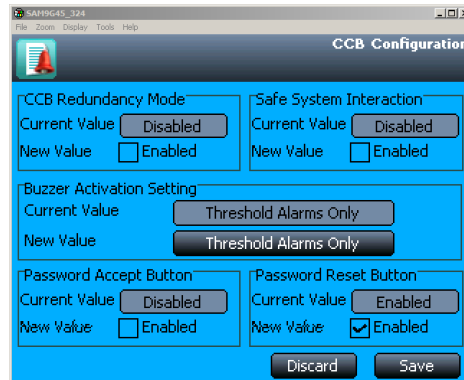

Figure 81. CCB Configuration Screen

12.5.1 CCB Redundancy Mode

The **CCB Redundancy** check box informs the system whether a backup (redundant) CCB assembly is fitted. If **Disabled**, the controller will not check for a second CCB and, if one is fitted, will not use it.

If **Enabled** but a backup CCB is not fitted, a second CCB will be shown as faulty in the **System Setup** tree, and the system will indicate a fault.

Note: This parameter is not stored in a **System Backup** and should be checked and re set if necessary following a **System Restore**.

12.5.2 Safe System Interaction

The **Safe System Interaction** setting requires the user to confirm all **Reset**, **Inhibit** and **Accept** operations when using the touch screen or the webserver. When **Enabled**, a confirmation popup is displayed showing the requested operation as shown below. A user may cancel the operation, or confirm the operation to continue.

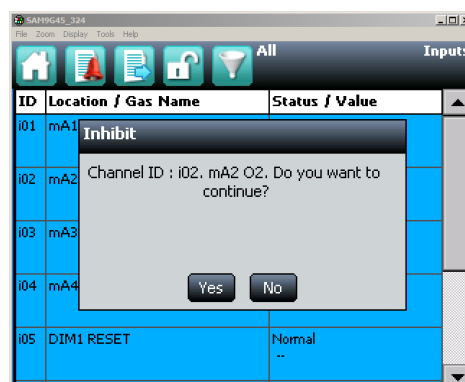

Figure 82. Safe System Interaction Screen



WARNING

Safe System Interaction must be **Enabled** for system required to meet **European Performance** requirements and to maintain compliance with **SIL** requirements.

CONFIGURATION

12.5.3 Buzzer Activation Setting

Selects the events on which the buzzer will sound.



Figure 83. Select Buzzer Screen

12.5.4 Password Accept Button

This button restricts use of the Accept button to authorised users. If **Enabled**, users must log in to **Accept** events such as alarm and fault indications using the front panel push button.

Default is **Disabled**.

12.5.5 Password Reset Button

This button restricts use of the **Reset** button to authorised users. If **Enabled**, users must log in to **Reset** alarms using the front panel push button.

Default is **Enabled**.

NORMAL OPERATION

13 Normal Day-to-Day Operation

There are several methods of interacting with TPPR:

- Controller Touchscreen (Supplied)
- PC Configuration Software (Licensed Option)
- Webserver (Licensed Option)
- Modbus (Option)

13.1 TPPR Controller Touchscreen Interface

The Touchscreen allows authorised users direct control of all of the TPPR functions. These functions are fully described in the TPPR manual suite.

13.2 TPPR PC Configuration Software Interface

PC Configuration software is an optional remote method for accessing the TPPR via a secure local Network connection.

The PC Configuration tool allows an authorised remote user to configure the controller, and to remotely view or amend the controller configuration.

The PC Configuration Interface is broadly similar to the Touchscreen Interface described in this manual but please refer to the downloadable PC Configuration User Guide for information on licensing, setup and day-to-day running.

PC Configuration software requires the TPPR controller to be configured with a unique static IP address, which is normally obtained from your site IT department.

Note: You may need **Administrator** privileges on the host PC.

13.3 TPPR Webserver Interface

The Webserver Interface is an optional remote method for accessing the TPPR display and viewing live TPPR events via an Ethernet connection. Events can be acknowledged and reset using the appropriate access passwords and event history can be analysed. Reports can be generated and saved or viewed on the host PC.

The Webserver allows an authorised remote user to Accept and Reset events on the controller, and to Inhibit channels, or clear Inhibits.

The Webserver Interface is broadly similar to a limited version of the Touchscreen Interface described in this manual. Refer to the downloadable Webserver User Guide for information on licensing, setup and day-to-day use.

The TPPR controller requires a static IP address for use with the Webserver, normally obtained from your site IT department.

NORMAL OPERATION

13.4 TPPR Safety Function

During normal Day-to-Day operation:

- The TPPR system will collect data every 250 ms from all of the **Input/Output** modules on the **Ring Network**
- The **Cause and Effect** matrix will be evaluated every 250 ms, and commands sent accordingly to the appropriate output channels. System response time for AIM is ≤ 3 s and ≤ 1 s for DIM
- Any change in status of an I/O channel will be reported to the **User Interface** and logged in the **event history**
- Any occurrence of any of the events listed in *Chapter 18 Error Codes* will be reported on the User Interface and logged in the event history
- Any system fault or inhibit will cause the **System Fault** relay to open
- Any failure of the safety function e.g. due to major fault or power loss will cause the **System Failure** relay to open



WARNING

High 'off-scale' readings may indicate an explosive concentration.

AVERTISSEMENT

Des résultats dépassant considérablement l'échelle peuvent être indicateurs d'une concentration explosive.

13.5 Touchscreen Operation

During normal operation the Touchscreen should show a menu bar at the top and a green tick on the main screen below it. During active events the status changes and an alarm may sound.

Users may touch the screen to show further menus or descriptions (some menus require password access).

A table of icons is given at *Chapter 24*.

13.5.1 System Status Screen Alert Icons

The **System Status** screen provides a summary of the TPPR status using **Alert Icons** accompanied by the text in bold:





	System OK All input and output channels are Normal		Fault One or more channels are in Fault
	Alarm One or more input channels are in Alarm		Inhibit One or more channels are in Inhibit
	Warning One or more Warnings are active		

Table 37. System Alert Icons

NORMAL OPERATION

13.5.2 Active Event History

The **Active Events** screen lists the current event history in the order that the events occurred, and in colour (Red, Yellow, Orange and Grey) to highlight the severity. TPPR has the option to filter the history into categories, and this is described in *Ch. 14.8 Responding to Alarms, Faults and Warnings*.

13.5.3 Touchscreen Layout

The two main Touchscreen displays are shown in the figure below. The top row shows touch sensitive icons as described in *Ch.24 Table of Icons*.

Figure 85 may be accompanied by external beacons, sounders and other events depending on your system setup. You can touch each of the alarms, faults or warnings to identify the cause and to acknowledge them as described later.

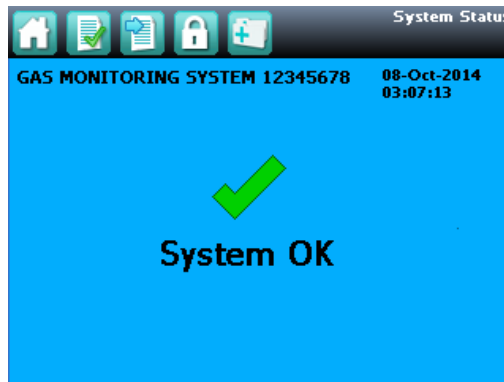

Figure 84. System Status Normal

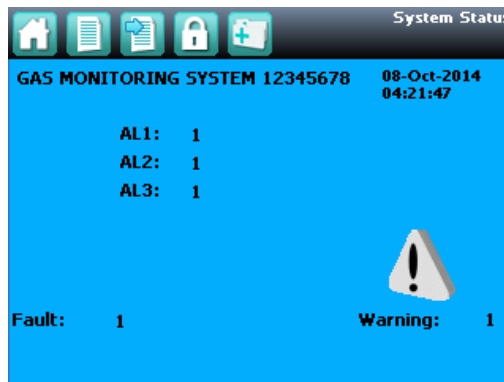
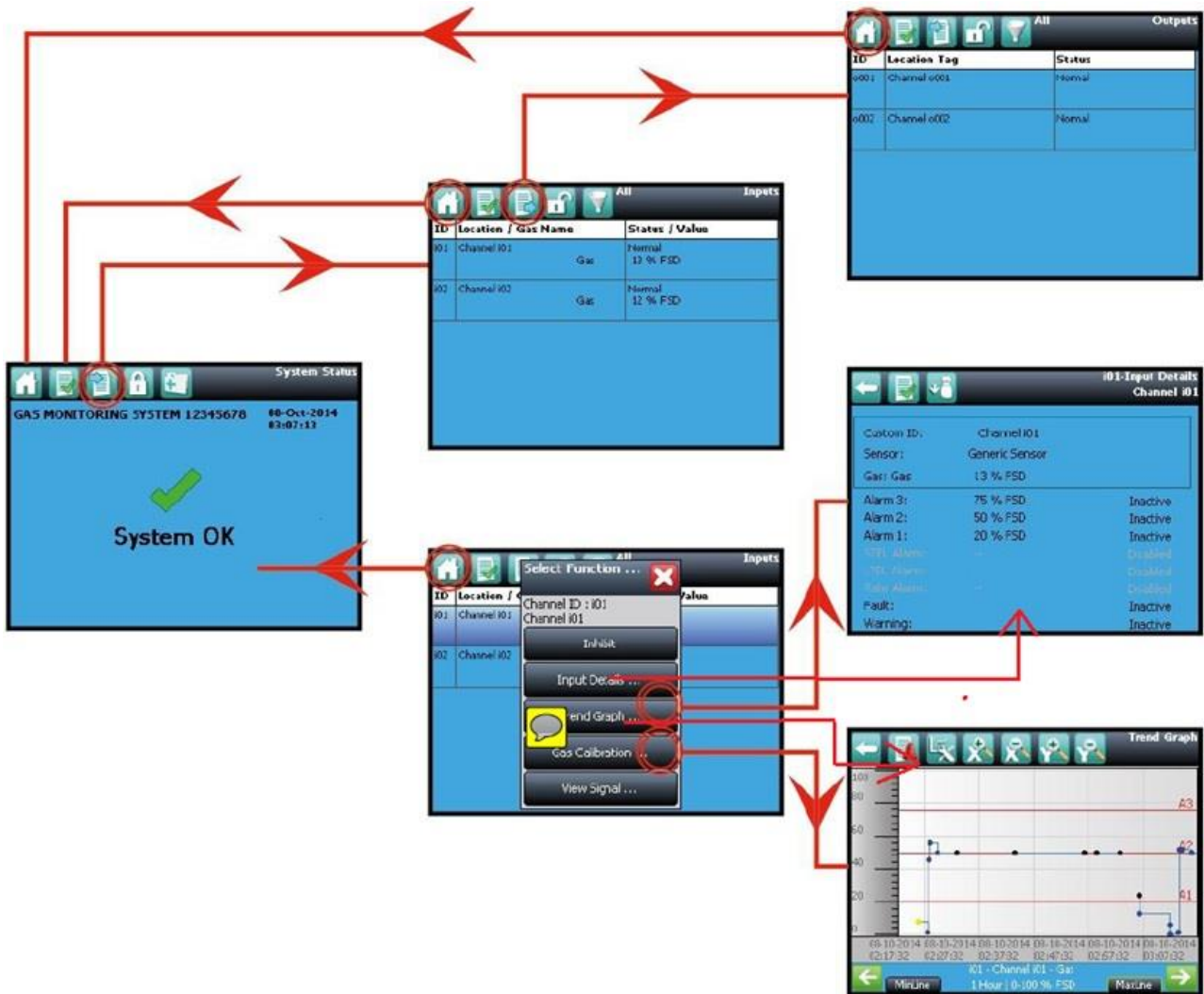

Figure 85. System Status with Example Active Events

NORMAL OPERATION

13.5.4 Touchscreen Navigation

The icons in the navigation bar are used to navigate through the User Interface Software.



Key



	System Status (Home)		Back
	Inputs		Outputs

Figure 86. Touchscreen Navigation – Input and Output

NORMAL OPERATION

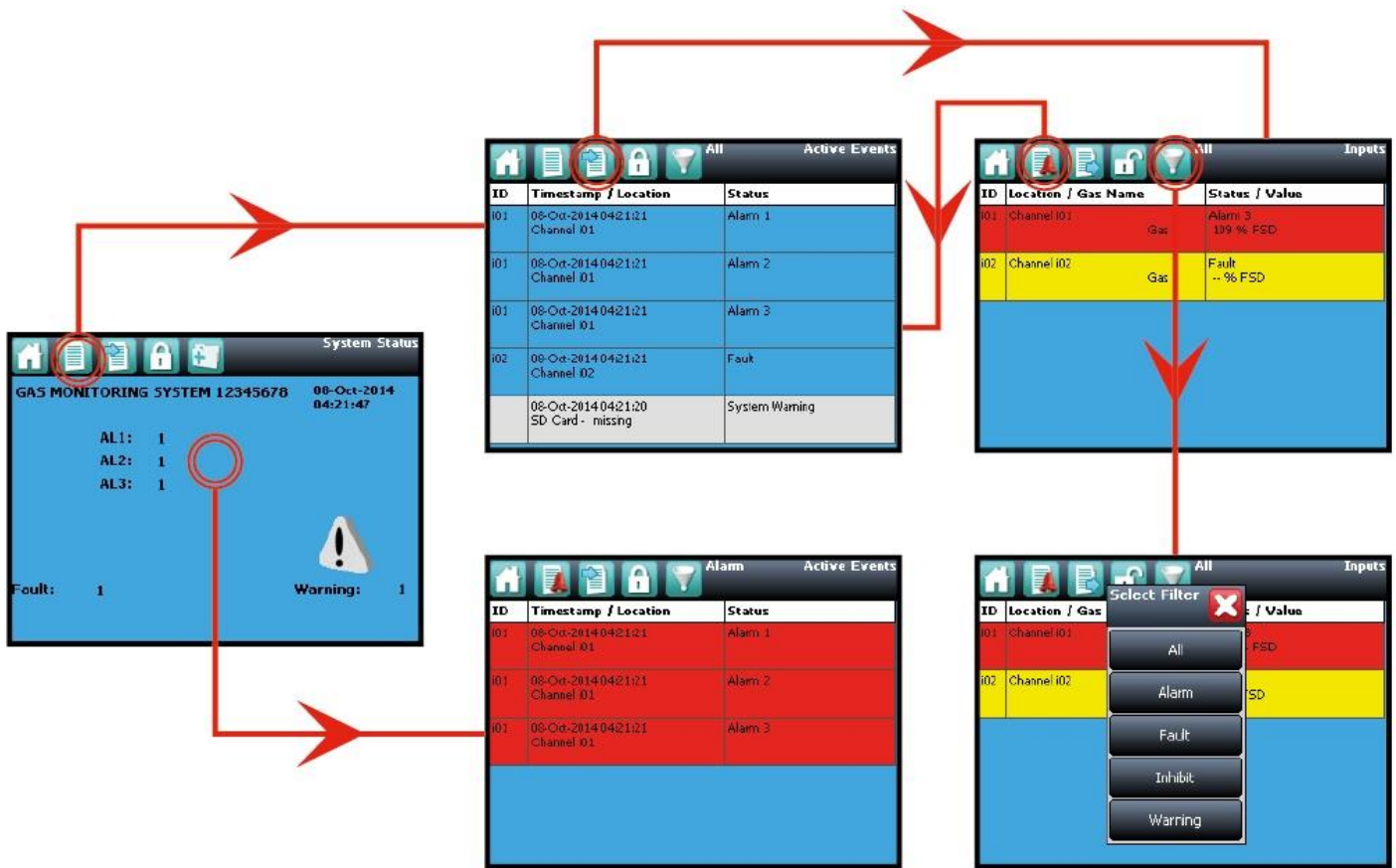

Key

	Active Events		Login
	Filter Events		User Logged In
	Inputs		Tool Box

Figure 87. Touchscreen Navigation – Active Events

NORMAL OPERATION

13.5.5 Login Requirements

To login you must be a registered **Administrator**, **Engineer** or **Operator** and have a valid password.

To login, touch the **Login** icon (closed padlock) in the navigation bar and enter the **User Name** and **Password**. The padlock will then change to an open padlock, indicating that a user is logged in.

Note: The user will be automatically logged out after 20 minutes of inactivity or if PC Configuration software assumes remote control. If Touchscreen calibration was in progress you must complete the calibration and log in again before you can proceed with any other actions.

13.6 How to Recalibrate the Touchscreen

13.7 Touchscreen Calibration

Recalibrate the Touchscreen if it does not respond correctly when touched. This process should take less than a minute but can only be performed at the Touchscreen.

Calibration must be fully completed once started as there is no option to abort the process.

To recalibrate the Touchscreen:

1. Login as **Engineer** or Admin
2. Select **Tool Box>Global Settings>Panel Configuration>Calibrate Touch Panel**
3. Follow the instructions, using a finger or soft stylus to touch each panel corner in turn
4. Finally touch the panel centre to exit

Note: The Fault LED may show if calibration is started but not completed, but will stop when calibration is fully completed.

Note: Screen calibration does not time out even when the backlight or UI times out, and user commands will not be available until calibration is fully completed. You must complete the Touchscreen calibration first, and then you can carry on with other activities.

13.8 How to View Input Channels and Input Details

Note: In the Touchscreen view, the **Inputs** and **Outputs** icons toggle – from the **System Status** screen navigation bar only the **Inputs** icon is visible, and when you change to the **Inputs** screen the **Outputs** icon becomes visible.

1. From the **System Status** screen navigation bar, select the **Inputs** icon.
2. A list of all input channels is shown in order of **Channel ID**. The Channel ID, location tag, gas name, status and current reading are shown.
3. The list can be filtered by status – **Alarm**, **Fault**, **Inhibit**, **Warning** or **All**.
4. Select a channel. Choose one of the options described in the table below.

Option	User Level	Comment
Inhibit	Engineer	Inhibits the channel. On an inhibited channel, this option changes to Clear Inhibit .
Calibration	Engineer	Calibrate the channel.
Trend Graph	All	Shows the trend graph for the channel.
Input Details	All	Shows detailed information about the channel including Custom ID , sensor and gas name, gas reading, configured alarms and alarm levels.
View Signal	Administrator	Shows the raw signal being received on the channel.

Table 38. Input Channel Menu Options

NORMAL OPERATION

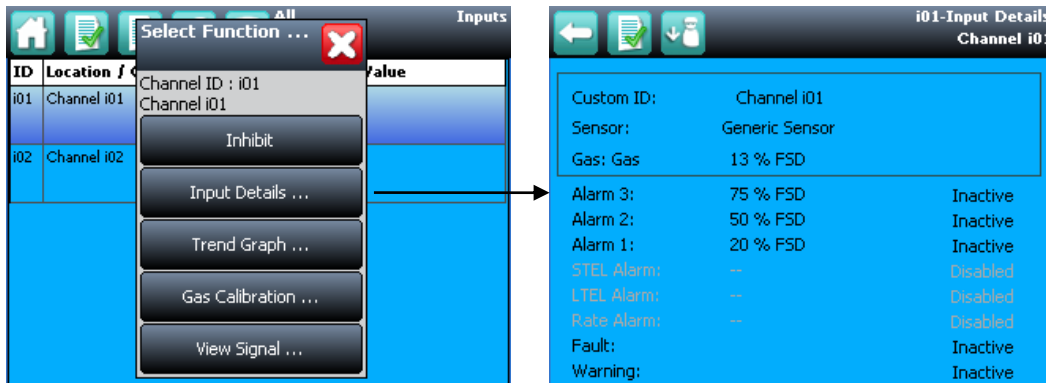

Figure 88. Input Details Screen

13.9 How to View Output Channels

In the Touchscreen view, the **Inputs** and **Outputs** icons toggle – from the **System Status** screen navigation bar only the **Inputs** icon is visible; selecting the **Inputs** icon makes the **Outputs** icon visible.

1. From the **System Status** screen navigation bar, select the **Inputs** icon and then the **Outputs** icon.
2. A list of all output channels is shown in order of Channel ID with its location tag and status as shown below:

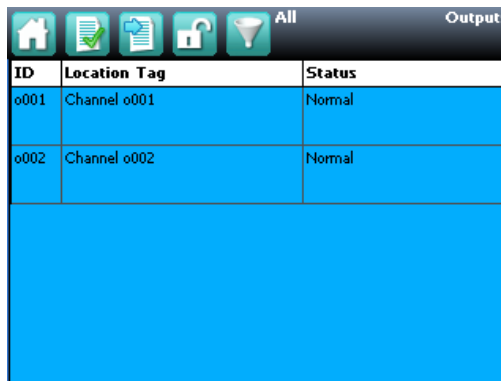

Figure 89. Outputs Screen

3. Select the **Filter** icon to filter by status – **Fault**, **Inhibit**, **Warning** or **All**, as shown below:



Figure 90. Outputs Screen with filter options

4. Select a channel. Depending on your access level, a number of options may be shown:

NORMAL OPERATION

Function	User Level	Comment
Inhibit	Engineer	Use this option to Inhibit the channel. Once selected this option changes to Clear Inhibit .
Force	Engineer	Use this option to Force a relay output channel to its active state. Once selected this option changes to Clear Force . The channel status changes to Fault.
Force Deactivate	Engineer	Use this option to Force a relay output channel to its deactivated state. Once selected this option changes to Clear Force . The channel status changes to Fault.

Table 39. Inhibit / Force Options

13.10 How to View the Trend Graph

The trend graph shows the history of the signal on an analogue input channel. The signal value is logged when it changes, or every one hour if there is no change.

Note: TPPR does not adjust automatically for daylight savings time. Be aware that if the date and time are changed to a time in the past, (for example ending daylight savings time) TPPR will retain a backup of the previous data.

Note: TPPR logs the trend data point when the system is in Field Inputs Test Mode, but does not log it when in the Configuration Settings Test or Cause and Effect Test modes.

Note: The system logs when the value changes, with a resolution determined by the gas range of the channel. For a gas range of less than 10, the resolution is 0.01, for a gas range of 10 to 99 the resolution is 0.1, and for a gas range of 100 or more, the resolution is 1.

Note: The display may not show negative values. If negative values are suspected, due to zero drift or an input fault, use the Trend Graph Settings icon to offset the Y axis zero.

13.10.1 To View the Trend Graph

1. From the **System Status** screen navigation bar, select the **Inputs** icon.
2. A list of all input channels is shown in order of **Channel ID**.
3. Select the required channel, and select **Trend Graph** from the popup menu.
4. The trend graph will be displayed.
5. Use the forward and backward arrows to scroll through the graph. Expand or reduce the axes using the X+, X-, Y+ and Y- buttons.

If there are more data points than the number of pixels available on the screen, TPPR will display the maximum value within each set of points. This is the **MaxLine**. (For example, if one pixel needs to represent 12 seconds, it will display the maximum value that occurred during those 12 seconds.) If you toggle to **MinLine**, TPPR will display the minimum value within each set of points.

Note: Webserver (if used) will by default display both **MaxLine** and **MinLine**. This can be changed to show only **MaxLine**, only **MinLine** or both.

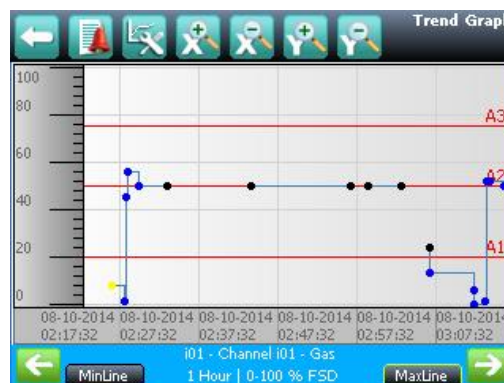

Figure 91. Trend Graph Screen

NORMAL OPERATION

13.11 How to View Event History

The event history for the complete system can be viewed in date order (latest first). The history can be filtered by Alarm, Fault, Inhibit, Warning, All or by selecting a date range.

To access event history, from the **System Status** screen navigation bar select **Tool Box**, then **Event History** or in Webserver directly select the **Event History** icon.

Note: The event history time stamp resolution is ± 5 seconds.

Note: TPPR does not adjust automatically for daylight savings time. Be aware that if the date and time are changed to a time in the past, (for example ending daylight savings time) TPPR will retain a backup of the previous data.

13.12 How to View Event Reports

Several report types can be generated. Reports can be saved to a memory device such as SD or USB, or printed if a printer is connected and configured. Saved reports cannot be viewed until the memory device is opened in a PC.

You can use the UI filters to generate:

- Trending for a specific channel, date range is selectable
- Channel events for a specific channel, date range is selectable
- Configuration for a specific channel
- All events within a selectable date range
- Calibration Report
- System Configuration Report

13.12.1 How to Generate Reports

The report is generated as a Comma Separated Value (.csv) text file.

Depending on the amount of activity, text files can be excessively long and difficult to interpret when printed so it is advisable to import the file into a spreadsheet and use the spreadsheet tools to organise the data.

Webserver (if used) can save or automatically open the report in Microsoft Excel or in a text editor.

Microsoft Excel 2003 is limited to a maximum of 65,526 entries so, if the report is too large, a '*File not loaded completely*' message may be generated. Microsoft Excel 2010 has no such restriction.

To generate a report:

1. From the **System Status** screen navigation bar select **Tool Box**, then **Report**
2. Select the type of report required (see section above), and if applicable select the channel required
3. Select required start and end dates and times
4. Select **Save** or **Print** as required

Note: The Save/Print option is disabled until a channel is selected.

Note: TPPR does not adjust automatically for daylight savings time. Be aware that if the date and time are changed to a time in the past, (for example ending daylight savings time) TPPR will retain a backup of the previous data.

13.13 How to Access Diagnostic information

Engineer access level is required.

The **Diagnostics** screen gives information about the firmware versions of system components, and details of the status and any errors. This information could be required by Honeywell Analytics to assist with technical support. The Diagnostics screen also provides access to the TPPR system test modes (see *Ch. 16 How to Test the TPPR System*).

To access **Diagnostics**, from the **System Status** screen navigation bar select **Tool Box**, then **Diagnostics**. The Diagnostics screen also provides access to a drop-down menu that offers the following tests:

- LED Panel Test
- Field Inputs Test
- Configuration Settings Test
- Cause and Effect Test
- System Relay Test
- Panel Button Test
- LCD Screen Test

Further information can be found in *Ch. 16 How to Test the TPPR System*.

NORMAL OPERATION

13.14 Managing the Integral SD Card

TPPR is supplied with a 4 GB Industrial Grade FAT32 SD card installed, although you can replace it with a larger card if required. Replacement SD cards should be the same industrial standard to ensure longevity and to protect against data loss.



WARNING

The SD Card is located inside the TPPR Controller's enclosure. Always ensure that the local atmosphere is safe before opening the enclosure..

It is not necessary to 'power off' when removing/inserting an SD Card but **do not touch any exposed terminals or wiring.**

13.14.1 SD Card Purposes

The Controller's SD Card is used for:

- Ongoing storage of event and trend data
- Storage of locally generated reports
- Storage destination for backup files
- Storing configuration backup files
- Internal system management

13.14.2 SD Card Management

The SD card should not normally be removed from the controller. If it is necessary to remove the SD card the controller will continue to cache event and trend data until the SD card is re-inserted.

The following points should be noted:

- The controller will not accept an SD card containing data for another TPPR system.
- Take care to re-insert the correct SD card, or a permanent replacement. The controller will flush cached data to the SD card when a card is re-inserted. If a different SD card is fitted data will become fragmented and may not be useable.
- Similarly, when an SD card has been replaced, the original SD card **should not be re-fitted** for the same reason.
- The TPPR will continue to operate normally with no SD card fitted. The controller can cache several hours of events in internal memory. When the cache is full the oldest data is overwritten and cannot be recovered.
- The TPPR will continue to operate normally with a full SD Card. When the card is full the oldest data will be overwritten. The overwritten event and trend data cannot be recovered.
- The TPPR will warn when the SD card is 80% full, when the card is full, and when previous data is being overwritten

13.14.3 How to Check the SD Card Capacity

From the **System Status** screen navigation bar, select **Tool Box>SD Card** to show the card's capacity and unused space.

13.14.4 Ejecting the SD Card

Event and trend data is held in system memory and saved to the SD card several times per minute.

To ensure that chronology is correctly maintained, and to minimise loss of event history data, always use the '**Eject SD Card**' command before removing the SD Card from the TPPR, and subsequently reinsert the same or a permanent replacement card in the system as soon as possible. When the command '**Eject SD Card**' is used, the data currently held in system memory is immediately downloaded to the SD Card.

13.14.5 Replacing an SD Card

Before replacing an SD card, event and trend data should be exported to report files, using the Touchscreen or the Webserver. The source files cannot be read by commercial office software. See *Ch. 13.12 How to View Event Reports* for further information.

The new card requires no special preparation but should be unlocked and formatted. Prior to installing you may want to use a card reader to copy the TPPR Configuration directory and recent backup files from the old SD card to the new one.

Note: SD Cards must be formatted to **FAT32** only; other file systems are not supported and will not work.

NORMAL OPERATION

13.15 Accessing Help

From the **System Status** screen navigation bar, select **Tool Box**, then **Help**. This help screen will show the date of the last configuration change, configuration version, previous user, about TPPR and the service contact options.

The configuration version increments every time that parameters are written to the TPPR, including during calibration. The configuration version can also be used as a check against unauthorised modification of the system.

- Select About to view software and firmware versions.
- Select Service Contact for details of how to access technical support.

13.16 System State Relays

The Control Module has two **System State** relays, rated at 30 VDC, 3 A or 250 VAC, 3 A. The contacts are closed in normal operation and open under the following conditions:

- The **System Fault** relay is open if one or more of the conditions listed in Table 40. are present.
- The **System Failure** relay is open if one or more of the conditions listed in Table 40. are present.

The **System State** relays and any other relays configured for safety purposes should be wired to a continuously monitored system for safe operation. This is to ensure that all system faults are detected promptly and appropriate action taken.

Note: During start-up, the **System Failure** relay is open until the CCB is available.

Note: The Redundant CCB taking over from a failed Master CCB is not considered to be a system failure, and the **System Failure** relay will remain in normal state.

System Failure Relay TB4	System Fault Relay TB5
Major power loss	Display unit internal fault
Fuse blown	Module diagnostics checks reported a fault
Controller software diagnostics failure detected	A channel is in inhibit, Fault or Warning state
Relay Test is being conducted in Test Mode	Redundant CCB takes over after Master CCB failed
	System is in Test Mode, other than LED and LCD Tests
	An output is an a Force or Force Deactivate state

Table 40. System State Relay Operation

13.16.1 ROM Output Relays on System Fail

Note: if there is a system failure all ROM output relays will de-energise, regardless of their configured states.

NORMAL OPERATION

14 Alarms, Faults, Warnings and Inhibits

TPPR may be set up to monitor many types of alarms in different areas of your site or sites. They may also be set up to react in different ways, such as:

- 'Latched' or 'Unlatched' alarms
- Short Term and Long Term Exposure Limits (STEL / LTEL) alarms
- Rate Alarm
- Activation of Relay Outputs
- Voting / Non-voting alarms
- Digital Inputs configured as alarms

14.1 Latching Alarms

During TPPR manufacture of Configuration the alarm channels will have been set as **Latched** or **Unlatched**. The default is usually **Latched**, but this can be changed if required.

Unlatched alarms self-reset once the hazard has cleared, while latched alarms require the user to verify that conditions are safe/normal before manually resetting the alarm.

The STEL alarm can be configured as latching or non-latching. STEL alarms should normally be set to latched to capture the event until it is acknowledged.

The STEL alarm can only be reset when TPPR has calculated that the average gas level over the STEL Time Interval has fallen below the STEL Alarm Level. Therefore, it will take a certain time before the STEL alarm can be reset even though there may no longer be gas present. The length of time before reset is possible depends upon the historic and current gas concentration/time relationship. If set to non-latching, the STEL alarm indication will persist until the average gas level over the STEL Time Interval has fallen below the STEL Alarm Level. See the next section for more detail.

14.2 STEL / LTEL Alarms



CAUTION

In some countries, the use of a STEL alarm with fixed gas detection equipment is not recommended. Refer to local and national regulations for further information.

Short Term Exposure Limits (STEL) and Long Term Exposure Limits are the toxic limits that the human body can tolerate without suffering acute or chronic distress, injury, illness or disease. These figures will vary with every chemical or gas, and they may vary again as more advanced and long-term laboratory testing produces new results.

TPPR uses analogue gas sensors to detect and record ambient toxic gas concentrations for STEL/LTEL. These readings have two functions: firstly a rise in gas concentration above a pre-set STEL base rate will trigger the STEL alarm and secondly a prolonged gas concentration above a pre-set LTEL base rate averaged over a period of time will trigger the LTEL alarm.

TPPR averages STEL gas levels every ½ minute over user-determined rolling periods ranging from 5 to 60 minutes and, for LTEL, continuously rolling periods of 10 minutes fixed at 8-hours total; i.e. 8 hours being the standard shift length.

Full details of STEL/LTEL theory and limitations are given in *Ch. 10 Configuring STEL and LTEL Alarms*, and details on setting it up are given in *Ch. 7 Software setup and Commissioning*.

NORMAL OPERATION

14.2.1 Using the STEL Alarm

Use the short term exposure limit (STEL) feature to indicate if a gas sensor is detecting an average level of gas that will result in a hazardous situation.

The STEL feature continuously calculates the average gas level over time using a user selectable time period (STEL Time Interval). An alarm will be indicated if the average gas level exceeds a user selected limit (STEL Alarm Level) within the STEL Time Interval.

STEL alarm functionality is normally associated with personal gas detection equipment where it will give information about an individual's exposure to a hazard. As TPPR and associated sensors are fixed equipment, the user must consider how the STEL feature is to be used as it is the sensor and not an individual that is exposed to gas.

The STEL function becomes active and starts monitoring the average gas level when the STEL alarm has been enabled and the input module returns to its normal state. If the STEL alarm had already been enabled prior to TPPR being powered down, then the STEL function becomes active when TPPR is powered up.

14.2.2 Assigning the STEL Alarm to an Output Relay

To assign an output relay to an input channel's STEL alarm, navigate to the cause and effect (C&E) matrix for the required relay and select Alarm 1 (AL1) for the input channel as shown in the figure below.

Threshold Alarm 1 and STEL share the output relay. If the channel is programmed for threshold levels then AL1 selection is used for the first threshold alarm and STEL may not be assigned to a relay. Similarly, if the channel is programmed for STEL, AL1 is reserved for STEL and may not be assigned to a threshold alarm.

This relay will also be assigned to the required inputs for Threshold alarm 1.

ID/Location	AL1	AL2	AL3	FLT	INH	WRN
Select All	<input type="checkbox"/>	<input type="checkbox"/>	<input type="checkbox"/>	<input type="checkbox"/>	<input type="checkbox"/>	<input type="checkbox"/>
133 – 1 mA Ch1	<input checked="" type="checkbox"/>	<input type="checkbox"/>	<input type="checkbox"/>	<input type="checkbox"/>	<input type="checkbox"/>	<input type="checkbox"/>

Select AL1 to assign this relay to the selected inputs STEL alarm. Note that this relay will also be assigned to the selected inputs alarm 1 threshold.

14.3 Rate Alarm

Rate Alarms can be setup to trigger when a gas concentration changes quickly. An alarm may be triggered by a rising or falling gas level even though the gas has not reached a threshold level. The extent of change and the time period are programmable.

14.4 Relay Activated Outputs

TPPR has the ability to automatically operate relay controlled outputs when an alarm is triggered. These outputs are determined during commissioning and may be used to control any or all of these:

- Light Stacks and Sirens
- Automated Emergency Services alerts
- Actuator controlled vents, valves and switches (i.e. power-breaking, purging, sprinkling or flooding)
- Exit door release
- Entry Barrier closing

NORMAL OPERATION

14.5 Sensor Over Range Operation

TPPR can display a warning if an input signal exceeds the configured gas range. Two signals are provided:

- Full Scale Exceeded
- Over Range Warning

The Full Scale Exceeded warning is displayed, if enabled, when the gas reading exceeds the programmed range. The warning is cleared automatically when the signal returns below 100% of the selected range.

The Over Range Warning is programmable. If enabled, the warning is displayed when the gas reading exceeds the programmed level (default is 110% of the programmed range).



WARNING

This **signal** must be configured to **Latching** to ensure compliance with *EN60079-29-1*.

The Over Range Warning has a higher priority than the Full Scale Exceeded warning. If the Over Range Warning is asserted, the Full Scale Exceeded warning is cleared.

14.5.1 Gas Readings

The maximum gas readings experienced may be seen by viewing the Trend graph.

14.6 Catalytic Sensor Over Range Operation

The reading from a catalytic sensor can return to a false low if the gas level exceeds the sensor operating range. The latched Over Range Warning indicates that an exceptionally high gas level has been detected and further investigation is required.

The Over Range Warning requires an extra Reset operation to clear. The first Reset clears the over range warning, the second reset clears any other conditions, provided that gas readings have returned to suitably low levels.

The Over Range Warning is available on mV channels (default: enabled) and on mA channels (default: disabled) for use with catalytic sensors connected via a mA transmitter.

14.7 Full Scale Exceeded and Over Range Warning Operation

The following two examples show the detailed operation of the **Full Scale Exceeded** and **Over Range Warning** warnings.

Note: For clarity alarms (AL1, AL2, AL3) and other conditions are not shown.

Pre-conditions:

- **Full Scale Exceeded** is enabled and set to **100%** of the pre-set gas range
- **Over Range Warning** is enabled and set to **120%** of the pre-set gas range (Latched)



WARNING

The **Over Range Warning** parameter must be configured to **100 %FSD** to ensure compliance with *EN60079-29-1*.

NORMAL OPERATION

14.7.1 Event Status with a Rising Gas Reading

Rising Gas Reading	Event Status (Full scale/Over Range)	Event History (Sequential Entries)	Remarks
Below 100%	—	—	—
≥100% & <120%	Full Scale Exceeded Active	Full Scale Exceeded Active	—
≥120%	Over Range Warning Active	Full Scale Exceeded Active Full Scale Exceeded Cleared Over Range Active	Full Scale Exceeded auto-cleared (overwritten by Over Range Warning)

Table 41. Rising Gas Reading

14.7.2 Event Status as the Gas Concentration Decreases

The indicated value remains at the programmed Over Range Warning value. A "greater than" symbol (>) is displayed to indicate that the programmed level has been exceeded. The latched reading may be reset once the gas concentration has decreased below the programmed level.

The **Over Range Warning** remains **Latched**.



WARNING

A potentially explosive gas concentration may still exist at this point.

Note: In the following example, **Full Scale Exceeded** will not reappear until the gas concentration falls to between 100% & 120% of the pre-set gas range and the latched **Over Range Warning** has been reset manually.

Falling Gas Concentration	Event Status (Full Scale/Over Range)	Event History (Sequential Entries)	Remarks
≥100% & <120%	Over Range Warning still Active (latched)	Full Scale Exceeded Active Full Scale Exceeded Cleared Over Range Active	Full Scale Exceeded is hidden while Over Range Warning is active.
≥100% & <120%	Full Scale Exceeded	Full Scale Exceeded Active Full Scale Exceeded Cleared Over Range Active Over Range Cleared Full Scale Exceeded Active	1 st manual reset attempted by user. Over Range Warning reset was successfully. Full Scale Exceeded may appear.
Below 100%	—	Full Scale Exceeded Active Full Scale Exceeded Cleared Over Range Active Over Range Cleared Full Scale Exceeded Active Full Scale Exceeded cleared	The 2 nd manual reset can be applied now and Full Scale Exceeded should auto-clear.

Table 42. Falling Gas Reading

NORMAL OPERATION

14.7.3 Action on Falling Alarms

Full Scale Exceeded and Over Range Warning may be set on channels using falling gas alarms, for instance oxygen. The warning acts on the configured full scale value.

For instance, if the full scale of an oxygen channel is set to 25% Vol, with Full Scale Exceeded set to 100% FSD and Over Range Warning set to 110% FSD then:

Full Scale Exceeded Warning	will be displayed when the gas reading exceeds 25% Vol
Over Range Warning	will be displayed when the gas reading exceeds 27.5% Vol

Table 43. Action on Falling Alarms

If no rising alarm is set on the channel, but the gas reading rises above the configured levels, a Full Scale Exceeded or Overrange Warning may be unexpectedly displayed with no corresponding alarm. This indicates a high concentration of gas not a low concentration.

14.8 Special Considerations when using Catalytic Sensors

Touchpoint Pro continually carries out diagnostics to prove that the system is operating correctly and faults such as wiring faults will clear automatically when the system detects that the fault has been corrected.

In rare circumstances (due to insufficient oxygen for the sensor to operate correctly) a high gas concentration could occur while the system is in fault, and which may not be detected by the system due to the fault. It is therefore *highly recommended* to configure at least one Relay Output to **latch on fault** on channels that are used with catalytic sensors.

14.8.1 Configuration of Relay Outputs

Each output must be configured as Normally Energized, Alarm Update Enable not selected, and Latch Function selected, as shown in the following example:

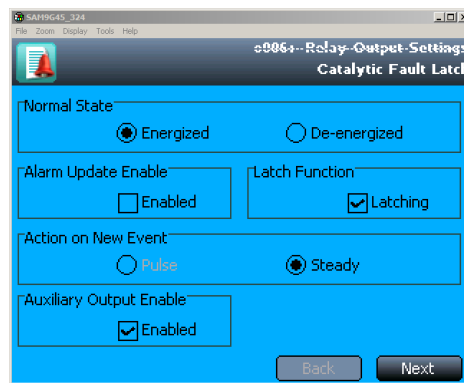

Figure 92. Fault Latch Output Configuration

Auxiliary Output **Enable** should normally be selected if any load is connected to the module auxiliary output supplies (e.g. a sounder or a beacon). A fault will then be generated if the output current limit is exceeded.

Each output must be configured as Output Type **Normal**, with a cause and effect matrix similar to the following example. The cause and effect matrix must include all channels using catalytic sensors, in this instance three mV channels.

ID/Location	AL1	AL2	AL3	FLT	INH	WRN
Select All	<input type="checkbox"/>	<input type="checkbox"/>	<input type="checkbox"/>	<input type="checkbox"/>	<input type="checkbox"/>	<input type="checkbox"/>
mV Channel 1	<input type="checkbox"/>	<input type="checkbox"/>	<input type="checkbox"/>	<input checked="" type="checkbox"/>	<input type="checkbox"/>	<input type="checkbox"/>
mV Channel 2	<input type="checkbox"/>	<input type="checkbox"/>	<input type="checkbox"/>	<input checked="" type="checkbox"/>	<input type="checkbox"/>	<input type="checkbox"/>

NORMAL OPERATION

mV Channel 3	<input type="checkbox"/>	<input type="checkbox"/>	<input type="checkbox"/>	<input checked="" type="checkbox"/>	<input type="checkbox"/>	<input type="checkbox"/>
At least One Alarm						
<input type="checkbox"/> Enabled		Vote Count		1		
		Channels Selected:		3		

To allow zoning of sensors it is possible to assign as many or as few input channels to the relay output channels as required, however it is a requirement of the *European Performance Approval* that **at least one channel is configured to latch** such a fault.

NORMAL OPERATION

14.9 Responding to Alarms, Faults and Warnings

Users may respond to alarms and other events by various methods.

All users may view events, as described below.

Events may be acknowledged or reset by various methods, including the controller front panel **Accept** and **Reset** buttons, touch screen menus, remote DIM-controlled switches, and, if enabled, Webserver and Modbus.

Access to controller **Accept** and **Reset** functions may be restricted to logged in users. The system may be configured so that the **Accept** and **Reset** buttons are password protected and require a user to login. See *Ch. 7 Software Setup and Commissioning* for further information.

Note: Switches and buttons connected to DIM channels may be used to provide remote **Accept**, **Reset** and **Inhibit** functions. These inputs cannot be password controlled so it is the user's responsibility to limit access, if required, by using other methods such as key operated switches. See *Ch. 7 Software Setup and Commissioning* for further information.

Note: Alarms may be commissioned as '**Latched**' or '**Unlatched**'. Unlatched alarms self-reset once the hazard has cleared, while latched alarms require the user to verify that conditions are safe/normal before manually resetting the alarm.



WARNING

High 'off-scale' readings may indicate an explosive concentration.

AVERTISSEMENT

Des résultats dépassant considérablement l'échelle peuvent être indicateurs d'une concentration explosive.



WARNING

Over range gas alarms should be investigated before attempts are made to reset them.

NORMAL OPERATION

14.9.1 To View Active Alarms

Active alarms can be viewed in three ways:

- From the **System Status (Home)** screen, select the flashing red bell **Alarm** icon.
- From the **System Status (Home)** screen navigation bar, select the **Active Events** icon, then the **Filter** icon and then select **Alarm** from the popup menu.
- From the **System Status** screen navigation bar, select the **Inputs** icon, then the **Filter** icon and select **Alarm** from the popup menu.

The screen will display a list of all the input channels that have active alarms, starting with the most recent event. Unacknowledged alarms will flash, acknowledged ones will not flash.

Note: The display shows the channel ID, location tag and the time of the alarm. All alarm levels will be shown if more than one alarm level has been triggered on the same channel.

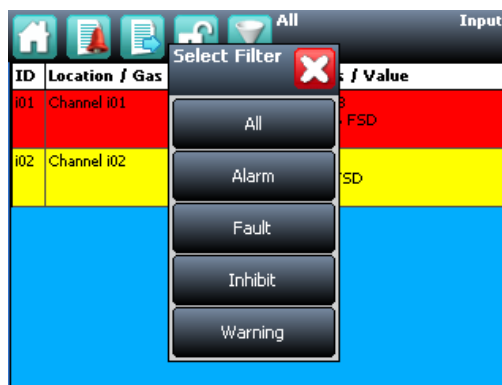

Figure 93. Active Events Screen with Filter Options

14.9.2 To Acknowledge an Active Alarm

An active alarm can be acknowledged from the controller in three ways:

- Select the **Accept** button on the front panel of the TPPR Controller for >0.5 s. This will acknowledge **all active events, including faults and warnings**.
- From the **Inputs** screen, select the channel and select **Acknowledge** from the popup menu. This will acknowledge **all active events for that channel only**.
- From the **Active Events** screen, select the alarm and select **Acknowledge** from the popup menu. This will acknowledge **only the selected alarm**.

Acknowledging an alarm silences the buzzer and the alarm icon stops flashing, but latched alarms are not automatically reset.

Note: The Alarm Update function modifies the operation of Output channels when events are acknowledged. Refer to Ch. 9.6.8 Alarm Update.

NORMAL OPERATION

14.9.3 To Reset a Latched Alarm

Alarms may only be reset if the event causing the alarm has been cleared; typically when the reported gas level has fallen below the alarm threshold.

If the **Over Range Warning** signal is latched, two **Reset** operations are required. The **first Reset** clears the **Over Range Warning**, the **second Reset** clears any other conditions.



CAUTION

The TPPR system is designed to alert the user to potentially dangerous events and to trigger protective measures. It is the User's responsibility to ensure that the site emergency response procedures are initiated before accepting alarms, and that the danger has been investigated and cleared before resetting the alarms.

Alarms cannot be reset until the gas concentration is below the threshold limits.

An **STEL Alarm** cannot be reset if the current value of the time weighted average (TWA) is above the pre-set alarm threshold.

An **LTEL Alarm** cannot be reset if the current gas reading is above the pre-set alarm threshold.

A latched alarm can be reset in three ways:

1. Select the **Reset** button on the front panel of the TPPR for >0.5 s. This will reset ALL latched alarms, faults and warnings, provided that the event has cleared. It will also reset any latched relay outputs.
2. From the **Inputs** screen, select the channel and select **Reset** from the popup menu. This will reset all latched events for the channel, provided that the input signal has returned to below the alarm threshold status.
3. From the **Active Events** screen, select the alarm and select **Reset** from the popup menu. This will reset only the selected alarm.

14.10 Viewing Faults and Warnings

The **Active Events** screen lists the current event history in the order that the events occurred. TPPR has the option to filter the history into categories, as shown in the descriptions and picture below.

Events are colour-coded for easier recognition; **Red** Alarm, **Yellow** Fault, **Orange** Inhibit, **Grey** Warning.

Faults and warnings may only be reset if the reported event has been cleared, for instance the fault has been rectified.

14.10.1 To View Faults and Warnings

Detailed information about active **Faults and Warnings** can be viewed in two ways:

From the **System Status** screen, select either the **Fault** yellow triangle icon, or the **Warning** grey triangle icon. The screen will show a filtered list of only the active Faults or Warnings.

Select the **Active Events** icon to show all active events, then the **Filter** icon and select **Fault** or **Warning** from the popup menu.

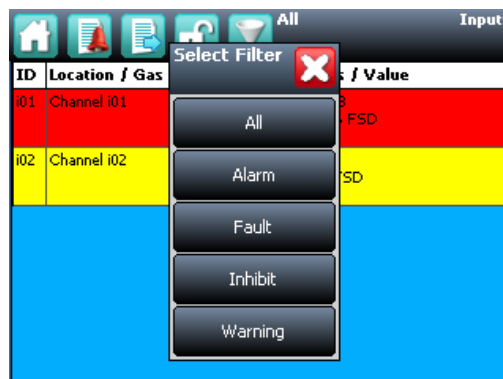

Figure 94. Active Events Screen Showing the Filter Option Buttons

NORMAL OPERATION

14.10.2 To Acknowledge (Accept) a Fault or Warning

Operator or higher access level may be required.

An active fault or warning can be acknowledged in three ways:

Select the **Accept** button on the front panel. This will acknowledge **ALL active events**.

From the **Inputs** or **Outputs** screen select the individual channel and select **Acknowledge** from the popup menu. This will acknowledge all active events for the channel.

From the **Active Events** screen, select the fault or warning and select **Acknowledge** from the popup menu. This will acknowledge only the selected fault or warning.

The channel, LED and icon will stop flashing when a fault or warning is acknowledged.

Note: The **Accept** button must be pressed for >0.5 s.

14.10.3 To Reset a Latched Fault or Warning

Operator or higher access level may be required.

A latched fault or warning can be reset in three ways:

- Press the **Reset** button on the front panel. This will reset **ALL latched alarms**, faults and warnings, provided that the event has cleared. It will also reset any latched relay outputs.
- From the **Inputs** or **Outputs** screen, select the channel and select **Reset** from the popup menu. This will reset all latched events for the channel, provided that the input signal has returned to Normal status.
- From the **Active Events** screen, select the fault or warning and select **Reset** from the popup menu. This will reset only the selected fault or warning.

Note: The **Reset** button must be pressed for >0.5 s.

14.11 Inhibiting a Channel

Engineer or **Administrator** access level is required.

If a channel is in Alarm, inhibiting the input will clear the alarm status for that channel. Inhibiting an output associated with that channel will deactivate that output, but the input will remain in alarm state. The alarm will continue to be reported on the controller and may affect other outputs in the cause and effect matrix.

Note: Channels may be inhibited automatically by the TPPR. See next page for more information.

14.11.1 How to Inhibit a Channel

Both input and output channels can be inhibited.

1. From the **System Status** screen navigation bar, select the **Inputs** icon and, if appropriate, the **Outputs** icon.
2. Select the required channel and select **Inhibit** from the popup menu.
3. To clear inhibits, select the required channel and select **Clear Inhibit** from the popup menu.

NORMAL OPERATION

14.11.2 Channel Auto-Inhibits

Auto-inhibits may occur when a mV input channel has been configured but not yet calibrated, when a transmitter is signalling Inhibit, or when an **Inhibit delay** time is running. Please refer to *Ch.17 Potential Issues* for further information.

Auto-inhibits cannot be cleared manually.



CAUTION

It is possible to have more than one inhibit condition active on a channel, and you have to resolve all inhibit conditions before the inhibit can be cleared.



Figure 95. Inputs Screen with menu options

MAINTENANCE

15 Maintenance Procedures

This chapter describes how to perform common maintenance operations.

The required frequency of inspection and maintenance will depend on local site conditions and will need to be established through experience. Please refer to the following standards or other local or national regulations for guidance on establishing an appropriate maintenance routine:

EN 45544-4 is a guide to selection, installation, use and maintenance of electrical apparatus used for the direct detection and direct concentration measurement of *toxic gases and vapours*.

EN 60079-29-2 is a guide to, and recommended practice for, the selection, installation, safe use and maintenance of electrically operated group II apparatus intended for use in industrial and commercial safety applications for the detection and measurement of *flammable gases*.

Note: When finished, ensure that all enclosures are closed and locked, and ensure that the maintenance and rectification is recorded.



WARNING

If the relays are switching mains voltages, hazardous live terminals may be present within the Relay Output Module even if the Touchpoint Pro system is isolated.

15.1 Routine Maintenance



WARNING

To avoid any unwanted activation of output devices (e.g. emergency flooding) always inhibit or disable relay activated outputs before exercising the relays and remember to enable them when testing is finished.



CAUTION

Do not use solvents or abrasives to clean any part of the TPPR as this may cause irreparable damage.

Routinely (i.e. daily, weekly or monthly depending on local conditions) carry out the following tasks:

- Clean the Touchscreen with a soft cloth and mild detergent, or use a proprietary VDU screen cleaner.
- Check the screen for correct operation. Recalibrate if necessary.
- Remove dust and other contamination (particularly on rack mounted units or enclosure vents).
- Periodically exercise the relays to confirm functionality (see *Ch. 16 How to Test the TPPR System*).
- Check that the SD Card still has free space.
- Check the condition of the enclosure for security, corrosion, deterioration of door seals, blocked ventilation, loose fixings and other damage that could impair the safety and operation of the equipment or its safety function.

MAINTENANCE

15.2 Periodic Maintenance

Periodic inspection and cleaning should be carried out weekly, monthly or 6-monthly as necessary.

Refer also to the recommended periodic system tests described in section 16.1.

15.2.1 Battery Enclosure Maintenance

Open the battery enclosure (if fitted) and:

- Visually inspect the Touchpoint Pro Battery Box, batteries and all exposed cabling, particularly for signs of corrosion.
- Check the batteries for physical security, cable damage, or loose connections.
- Check that the enclosure vents have not become obstructed. Remove debris with a vacuum cleaner nozzle, taking care not to disturb wiring or short the terminals.

Close and secure the door when finished.



CAUTION

The sealed batteries contain lead and acid. Treat all damaged batteries and leaks as hazardous spills, and dispose of the battery and contents as hazardous waste.

15.2.2 Cable Maintenance

Additionally, especially following ground maintenance or severe weather:

- Visually inspect all cabling and trunking, checking for signs of damage, perishing or loose connections.

MAINTENANCE

16 How to Test the TPPR System

16.1 Introduction

The TPPR system has the following test modes, which together enable a comprehensive test of the system:

1. **LED Panel Test** – tests that all of the panel LEDs are working.
2. **Field Inputs Test** – tests all input channel devices without affecting any outputs. Gas test, force mA, confirmation of correct device connection etc.
3. **Configuration Settings Test** – forces the TPPR input channels to specific levels and shows the corresponding states, threshold alarm levels, over-range, warning/fault etc.
4. **Cause and Effect Test** (carried out from the output channel menu) – forces the TPPR input channels to specific states to test that the correct output channels are activated.
5. **Panel Button Test** – tests that the panel buttons are working
6. **System Relay Test** – tests that the **System Failure** relay and **System Fault** relays are working
7. **LCD Screen Test** – provides a visual check of the LCD screen

Note: It is recommended that the audio / visual functionality of the system (test modes 1, 5 and 7) are tested annually. Test modes 2, 3 and 4 should be run as a part of commissioning or after any modification to the system which changes the system setup.

It is recommended that the system relays (test mode 6) and the Relay Output Module (Force) relays are tested at least every five years.



WARNING

While in test mode, the TPPR is not operational as a safety system and any field device inputs may be ignored. The **System Fault** relay may open and the **System Failure** relay will remain in the current state. Always put alternative safety arrangements in place before carrying out these tests.



WARNING

During the **Cause and Effect Test**, outputs will be generated and relays will be activated. To avoid any unwanted activation of output devices (e.g. emergency flooding) always inhibit or disable relay activated outputs before starting and enable them when testing is finished.

When a test mode is active the **System Fault** relay will normally open and a **Test Mode Fault** will be shown as an **Active Event** on the User Interface, which cannot be reset. The exceptions are the LED Panel Test and LCD screen, which do not indicate a fault.

Once a test mode is active, the system will remain in test mode until the test is exited. The only exception is in the case of a power cycle of the TPPR, when it will restart in normal mode.

Note: After 20 minutes of inactivity the system will logout and return to the **System Status** screen. However it is still running in test mode and you will need to login to complete the tests.

The optional **PC Configuration Software cannot be used** while a test mode is active.

All events generated while the system is in test mode will be logged in the event history. Therefore a test record can be generated once testing is completed (see *Ch. 7.6 How to Print Active Events*).



MAINTENANCE

16.2 LED Panel Test

Engineer access level is required.

The purpose of this test is to check that the LEDs on the panel are working correctly. This test does not indicate a Fault while in progress.

How to use the LED Panel Test mode:

1. Login as an **Engineer**.
2. From the **System Status** screen select the **Tool Box** icon: 
3. Select Diagnostics.
4. Select the **Menu** icon: 
5. Select **LED Panel Test**.
6. The system will ask you to confirm, select **OK** to proceed.
7. The system will illuminate all LEDs and then cycle through the LEDs turning each one on in turn.
Note: The green power LED will remain illuminated throughout if it is working correctly.
8. At the end of the test the system will ask you to confirm the LED test passed.



16.3 Field Inputs Test

Engineer access level is required.



During this test, all field device inputs will be displayed, but the **Cause and Effect** matrix will not be evaluated. No outputs will be generated.

The purpose of this test is to check that the input field devices are connected to the correct input channel. Typically, this can be done either by applying a test gas to the sensor in the field or by forcing the mA output of the sensor to a given value. The gas concentration and alarm states raised for the channel can then be viewed on the Touchscreen UI or PC GUI. The system fault relay will be open.

How to use the Field Inputs Test mode:

1. Login as an **Engineer**.
2. From the **System Status** screen select the **Tool Box** icon: 
3. Select Diagnostics.
4. Select the **Menu** icon: 
5. Select Field Inputs Test.
6. The system will ask you to confirm, select **Yes** to proceed.
7. The system will display a confirmation message, click on OK and you will be automatically navigated to the Active Events screen.
8. Proceed with the test of the field devices. To see more detailed information at any time, select the channel of interest and select Input Details from the popup menu.

Note: If the test is done from the **Active Events** screen, the channel of interest will be shown as soon as its state changes, i.e. a threshold alarm is generated. Alternatively, you may wish to work from the Inputs screen (return to System Status screen and select Inputs) by scrolling down to the channel you want.

9. When the test is complete, return to the **System Status** screen and select the **Tool Box** icon: 
10. Select Diagnostics.
11. Select the **Menu** icon: 
12. Select Stop Field Inputs Test.
13. The system will show a confirmation message that it has returned to normal operation.



WARNING

Check and ensure that the system is restored to normal operation once all testing is finished.

MAINTENANCE







16.4 Configuration Settings Test

Engineer access level is required.

During this test, all field device inputs will be ignored by the TPPR. The **Cause and Effect** matrix will not be evaluated. No outputs will be generated.

The purpose of this test is to check that input channels are configured correctly, including alarm, warning, fault thresholds etc. The gas concentration and alarm states raised by forcing the input value can be viewed on the TPPR UI or the PC GUI. The system fault relay will be open.

16.4.1 How to use the Configuration Settings Test Mode

1. Login as an **Engineer**.
2. From the **System Status** screen select the **Tool Box** icon: 
3. Select Diagnostics.
4. Select the **Menu** icon: 
5. Select Configuration Settings Test.
6. The system will ask you to confirm; select **Yes** to proceed.
7. The system will display a confirmation message, click on **OK** and you will be automatically navigated to the **Inputs** screen.
8. Select the channel to be tested and select **Input Details** from the popup menu.
9. From the **Input Details** screen, select the **Menu** icon: 
10. Select Force Value.
11. Enter the gas concentration that you want to simulate. This can include over and under range values.
12. The system will return to the **Input Details** screen, where it will show the simulated gas value as well as any corresponding active events (e.g. Alarm 1).
13. When ready, select the **Menu** icon: 
14. Select Clear Force.
15. Repeat steps 9 – 14 as required, completing the channel tests.
16. Return to the **Inputs** screen and repeat steps 8 – 14 for the next channel.
17. When the test is complete, go to the **System Status** screen and select the **Tool Box** icon: 
18. Select Diagnostics.
19. Select the **Menu** icon: 
20. Select Stop Configuration Settings Test.
21. The system will show a confirmation message that it has returned to normal operation.



WARNING

Check and ensure that the system is restored to normal operation once all testing is finished.

MAINTENANCE

16.5 Cause and Effect Test

Engineer access level is required.

During this test, all field device inputs will be ignored by the TPPR system. The **Cause and Effect** matrix will be evaluated based on simulated input states and outputs will be generated. The system fault relay will be open.







WARNING

During the Cause and Effect Test, **outputs will be generated and relays will be activated**. To avoid any unwanted activation of output devices (e.g. emergency flooding) always inhibit or disable relay activated outputs before starting and remember to enable them when testing is finished.

This test has two purposes:

1. To verify that Cause and Effect matrix configuration is correct by forcing the state of the input channels to various combinations. The activated/de-activated output channels corresponding to the forced state of input channels can be viewed on the TPPR UI or Webserver (if enabled).
2. To check that the output channels are configured correctly, including delay on/off times etc. By forcing the state of the output channel to change the corresponding change in the output device state can be viewed on the TPPR UI or Webserver (if enabled).

16.5.1 How to use the Cause and Effect Test Mode:

1. Login as an **Engineer**.
2. From the **System Status** screen select the **Tool Box** icon: 
3. Select **Diagnostics**.
4. Select the **Menu** icon: 
5. Select **Cause and Effect Test**.
6. The system will ask you to confirm, select **Yes** to proceed.
7. The system will display a confirmation message, click on **OK** and you will be automatically navigated to the **Outputs** screen.
8. Select the channel to be tested and select **Output Details** from the popup menu.
9. Select the **Menu** icon: 
10. Select **Force Input States** to do a full test of the **Cause and Effect** matrix (test purpose 1 described above).
11. The system will display a matrix of all the input channels that are linked to the output channel being tested.
12. Select the input channel states that you want to simulate, and click on **Force**. The cells corresponding to the forced states will be coloured.
13. The system will return to the **Outputs** screen where the results of the forced input states can be viewed.
14. When ready, return to the **Output Details** screen and select the **Menu** icon: 
15. Select **Clear Force**.
16. Repeat steps 8 – 15 for the next channel.
17. To force the output relays (test purpose 2, described above) select the channel to be tested and select **Output Details** from the popup menu.
18. Select the **Menu** icon and select **Force** from the popup menu. The output will now be activated and the result can be verified.
19. When ready, select the channel again, and select **Clear Force**.
20. Repeat steps 17 – 19 for the next channel.
21. When the test is complete, go to the **System Status** screen and select the **Tool Box** icon then **Diagnostics**.
22. Select the **Menu** icon: 
23. Select **Stop Cause and Effect Test**.
24. The system will show a confirmation message that it has returned to normal operation.



WARNING

Check and ensure that the system is restored to normal operation once all testing is finished.



MAINTENANCE

16.6 Panel Button Test

Engineer access level is required.

The purpose of this test is to check that the buttons on the panel are working correctly.

How to use the Panel Button Test mode:

1. Login as an **Engineer**.
2. From the **System Status** screen select the **Tool Box** icon: 
3. Select Diagnostics.
4. Select the **Menu** icon: 
5. Select **Panel Button Test**.
6. The system will ask you to confirm, select **Yes** to proceed.
7. The system will confirm you are in panel button test mode. Press **OK** to proceed.
8. Follow the on-screen prompts to test the panel buttons
9. At the end of the test the system will display the test results
10. Press **OK**.
11. Select the **Menu** icon: 
12. Select Stop panel Button Test.
13. The system will show a confirmation message that it has returned to normal operation.



16.7 System Relay Test

Engineer access level is required.

The purpose of this test is to check that the System Failure and System Fault relays are working correctly.

Note: It may be necessary to disconnect wiring to higher level systems from TB4 (System Failure) and TB5 (System Fault) on the TPPR controller. This test may cause higher level systems to activate if connected.

How to use the System Relay Test mode:

1. Login as an **Engineer**.
2. From the **System Status** screen select the **Tool Box** icon: 
3. Select Diagnostics.
4. Select the **Menu** icon: 
5. Select **System Relay Test**.
6. The system will ask you to confirm, select **Yes** to proceed.
7. The system will confirm you are in relay test mode. Press **OK** to proceed.
8. The system will operate the System Fail relay and ask the user to confirm the monitoring applied by the engineer has indicated that the relay has been activated (contacts closed).
9. The system will operate the System Fail relay and ask the user to confirm the monitoring applied by the engineer has indicated that the relay has been deactivated (contacts permanently open with no state switching).
Note: The System Fail relay will be toggling during this test to ensure that no contacts have welded
10. The system will operate the System Fault relay and ask the user to confirm the monitoring applied by the engineer has indicated that the relay has been activated (contacts closed).
11. The system will operate the System Fault relay and ask the user to confirm the monitoring applied by the engineer has indicated that the relay has been deactivated (contacts permanently open with no state switching).
Note: The System Fault relay will be toggling during this test to ensure that no contacts have welded.
12. At the end of the test the system will display the test results.
13. Press **OK**.
14. Select the **Menu** icon: 
15. Select Stop System Relay Test.
16. The system will show a confirmation message that it has returned to normal operation.
17. Reconnect TB4 and TB5 if necessary.



MAINTENANCE

16.8 LCD Screen Test

Engineer access level is required.

The purpose of this test is to check that the LCD screen is working correctly. This test does not indicate a Fault while in progress.

How to use the LCD Screen Test mode:

1. Login as an **Engineer**.
2. From the **System Status** screen select the **Tool Box** icon: 
3. Select **Diagnostics**.
4. Select the **Menu** icon: 
5. Select **LCD Screen Test**.
6. The system will display a series coloured bars and a progress bar.
7. When the progress bar completes the system asks you to confirm the bars were visible
8. Then select **Yes** if the bars were visible and **No** if the screen appears abnormal.



16.9 How to Exercise the Output Relays



WARNING

To avoid any unwanted activation of output devices (e.g. emergency flooding) always inhibit or disable relay activated outputs before exercising the relays and remember to enable them when testing is finished.

To test the Relay output channels by forcing the relays to a specific state:

1. Login as an **Engineer**. Navigate to the Outputs screen:
 - c) From the **System Status** screen select the **Inputs** icon: 
 - d) Toggle the Inputs Icon to select the **Outputs** icon: 
2. Select the channel to be tested, and then select **Force** or **Force Deactivate**, as required. The channel will indicate a Fault until the action is cancelled.
3. When ready, select the channel again, and select **Clear Force** from the popup menu.
4. Repeat steps 4 and 5 for all relay output channels.

Note: The system will indicate a fault and the System Fault relay will open while a Force condition is present.



WARNING

Check and ensure that the system is restored to normal operation once all testing is finished.

MAINTENANCE

16.10 How to Remove or Replace Modules

An I/O module, ROM or DIM can be replaced with another of the same type, without needing to re-program the configuration as TPPR can copy the configuration to the new module. However, see the **Warning** and **Cautions** below before proceeding.



WARNING

If the TPPR relays are switching mains voltages, hazardous live terminals may be present within the Relay Output Modules even if the TPPR is electrically isolated.



CAUTION

Avoid static discharge when installing or replacing any module.

Note: **Administrator** level access is required to decommission / recommission / reconfigure modules via software, but a qualified electrical engineer should carry out the physical work of removing or replacing the modules.

Note: **Replace** will only work if replacing with the same module type and only if Modification states are compatible. In addition, mV modules will require recalibration of used channels.

16.10.1 How to Remove or Decommission an I/O Module

1. Login as an **Administrator**.
2. Go to **System Setup**.
3. Decommission the channels / modules you want to remove. (You will get a warning later on if you fail to do this correctly.)
 - e) Identify whether or not the module's channels are in a **normal C&E Matrix**. To do this, try to decommission the channel and the software will tell you what outputs are associated with it (Error 49). However, no warning is given if the channel is in a **master C&E Matrix**.
 - f) Similarly, if the channel is in a remote interaction group associated with a DIM (i.e. remote acknowledge, reset etc.), you have to remove it from the DIM, and the quickest way is to try and decommission it as in (a) above.
4. If it is in a C&E or group, edit each output channel or DIM in turn to remove the link. To do this:
 - g) Note down which channel or DIM is affected as this information will be lost in decommissioning.
 - h) Edit each channel in turn, removing it from the **C&E Matrix**.
 - i) Return to the **System Setup** screen.
5. Decommission each channel.
6. Select **Remove**. The module will no longer appear on the **Ring** and can be removed when ready. (Do not manually re-initialise the ring or you will have to remove the module again.)
7. Disconnect the field equipment cables from the faulty module.
8. Remove the faulty module from the Communication / Power Rail by pulling down the clip at the bottom and easing the module carefully outwards before unhooking it from the top of the DIN rail.

Note: Decommissioning can be done in software with or without the module being present. If the module is present it will be set to an un-initialised state (flashing LED). It will show as a **Fault** if not present.

16.10.2 How to Remove or Decommission a ROM or DIM

ROMs and DIMs are removed in the same way as I/O Modules. It is the user's responsibility to consider any effects on the cause and effect matrix.

MAINTENANCE

16.10.3 How to Replace a Module

There are two ways to replace a module, e.g. replacing a faulty module or installing a different module type.

Note: It is not necessary for the new module to be in the same backplane slot as the module to be removed. The replacement module may be fitted and detected before the original module is removed, if required.

Note: Previous configuration backups will not be acceptable following the replacement or removal of modules. A new backup should be made as soon as possible.

Replace may only be used to replace a module with a module of the same type. All settings from the old module are transferred to the new module.

To replace a Module using 'Replace':

1. Disconnect and remove the failing module. Note its UDID number.
2. Fit the new module in its place, noting its UDID number.
3. Initialise the ring to detect the new module.
4. Select the module in the system setup view and select **Replace**.
5. The system will display a list of available unconfigured modules. Select the required module UDID number.
6. Follow the on-screen prompts to complete the process.
7. Back up the system.
8. Reconnect and test as required.

Note: Replace may be used to replace several modules in one operation.

To replace a Module using 'Remove':

Remove may be used to replace a module with the same type, or to fit a different module type.

1. Decommission the module, as described in *Ch. 16.10.1 & 16.10.2* above.
2. Select the module in the system setup view and select **Remove**.
3. Follow the on-screen prompts to complete the process.
4. Remove the module from the backplane.
5. Fit the new module and initialise the ring, as described below.
6. Commission and configure the new module and channels.
7. Back up the system.
8. Reconnect and test as required.

MAINTENANCE

16.10.4 How to Fit or Refit a Module

Fitting modules should not require any force.

1. Hold the module at a 30° angle with the top plastic hooks closest to the DIN rail, and then hook it onto the top edge of the DIN rail before pushing the bottom carefully into place so that the sliding metal hooks clip onto the DIN rail and the communication plug and socket engage fully.
2. Clipping the module to the DIN rail should not require any force so check that it is correctly aligned with the electrical connector before exerting pressure. Some modules have two slots at the rear of the module case so check that the correct slot is engaged.
3. Check that the module LED or LEDs are illuminated.

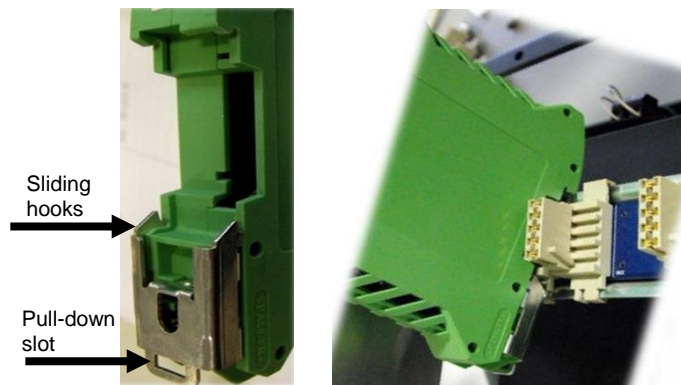

Figure 96. Fitting a Module to the DIN Rail

4. Re-connect the field equipment by plugging the field terminals into the new module.
5. Login as an **Administrator**.
6. From the System Status screen select the Tool Box icon then System Configuration.
7. Re-enter the **Admin password** and select **Login**.
8. Initialise the **Ring Network**. The newly inserted will be seen in the **System Setup Tree**.



CAUTION

Calibrate AIM mV modules after replacement.

MAINTENANCE

16.11 How to Add or Install a New I/O Module

The TPPR system can be expanded by adding new I/O modules to vacant sockets on the Communication Rail.

Note: **Administrator** level access is required to commission modules, but an authorised electrical engineer should carry out the wiring.



WARNING

If the TPPR relays are switching mains voltages, hazardous live terminals may be present within the Relay Output Modules even if the TPPR is electrically isolated.



CAUTION

Avoid static discharge when installing or replacing any module.



CAUTION

Calibrate AIM mV modules after fitment.

16.11.1 To Add or Install a New Module:

1. Fit the new module as described in the previous chapter.
2. Connect the field equipment by connecting the field cables to the new module.
3. Login as an **Administrator**.
4. From the **Home** screen select the **Tool Box** icon then **System Configuration**.
5. Re-enter the **Admin password** and select **Login**.
6. Initialise the Ring Network. The newly inserted module will appear in the **System Setup Tree**.
7. Select the new module and commission it.
8. Commission each channel in turn.

MAINTENANCE

16.12 How to Check the DC-UPS

The DC-UPS module has a range of LEDs that indicate UPS system states, as listed both on the DC-UPS module cover, and in the table below. These LEDs should be checked regularly and before isolating the battery or mains power supplies.

Note: TPRR batteries are replaced as a pair, 'Battery Centre Tap' is not used, and individual battery status is not shown.

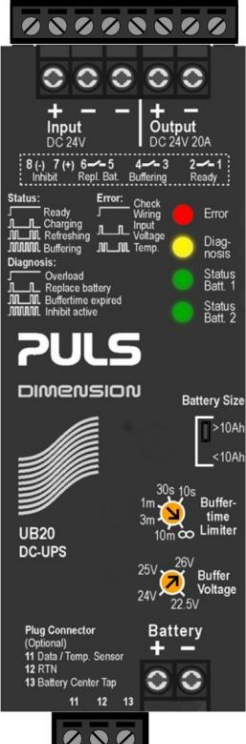

LED	Status	Flashing Sequence	Indication
Green	Good		Ready
			Charging
			Refreshing
			Buffering
Yellow	Caution		Overload
			Replace Batteries
			Buffertime Expired
Red	Fault		Inhibit Active
			Check Wiring and Fuse
			Check Input Voltage
			Check Temperature (Unused)

Figure 97. DC-UPS Signal Key

Key:	
Battery Size	Sets the charging current, This should be set to >10 Ah, which gives a charging current of 3.0 A.
Buffering	The input voltage is below the transfer threshold level, and the TPRR is running on battery power (buffering). See Buffertime below.
Buffertime	A DC-UPS supplying nominal DC 24 V @ 20A should provide power for ≈ 15 or 30 minutes with 12 Ah and 27 Ah batteries respectively. Normally set to infinite.
Buffertime expired	The battery output time has exceeded the setting on the Buffertime limiter, or buffering has been stopped to protect the batteries. This signal displays for 15 minutes only.
Buffertime Limiter	Sets how long the UPS will supply power. Usually set to infinity (∞), which allows the system to run until power is restored or until the batteries discharge below safe working limits.
Buffer Voltage	Sets the nominal charging power. Normally set to 24V. (PSUs are set to 26V to allow charging.).
Charging	The battery capacity is below 85 % and the batteries are charging.
Inhibit active	Indicates that buffering ability is disabled (charging of batteries will continue) or that a buffering event was aborted due to the inhibit function.
Input Voltage	Input voltage is lower than the selected Buffer voltage + 1.0 V, or higher than the input over-voltage protection (OVP) level.
Overload	Indicates if the output current is higher than specified values or that the DC-UPS has shut down during hiccup mode.
Ready	The battery charge is above 85 % and no faults are detected.
Replace batteries	Indicates that the batteries have failed the battery health check and should be replaced as soon as possible.

MAINTENANCE

16.13 How to Change the Battery Protection Fuse



CAUTION

To comply with regulatory requirements, use only Bussman 20 A Fast Acting 1.25" Type ABC-20-R fuses.

1. Ensure the atmosphere is safe.
2. Open the battery enclosure door.
3. Switch the Battery Isolator **OFF** (down).
4. Compress and twist both bayonet fuse holder ends anti-clockwise to open it.
5. Replace the fuse.
6. Engage and compress both bayonet fuse holder ends and twist them clockwise to lock it.
7. Switch the Battery Isolator **ON** (up).
8. Close the enclosure door.

16.14 How to Replace Batteries



CAUTION

To comply with regulatory requirements, use only Honeywell specified sealed lead-acid batteries.

1. Ensure the atmosphere is safe.
2. Open the battery enclosure door.
3. Switch the Battery Isolator **OFF** (down).
4. Remove the battery fuse.
5. Disconnect the battery terminals, observing the polarity for later reconnection.
6. Replace both batteries with:
 - TPPR-V-0406 12 V 12 Ah (FIAMM FG21202)
 - TPPR-V-0405 12 V 27 Ah (FIAMM FG22703)
7. Reconnect the battery terminals, ensuring the polarity is correct.
8. Test and refit the fuse.
9. Switch the **Battery Isolator ON** (up).
10. Check the **DC-UPS** indications to ensure that all is correct.
11. Close the enclosure door.

TROUBLESHOOTING

17 System Troubleshooting

This section explains how to deal with problems that may occur during system operation.

Contact Honeywell Analytics for support if required, using the contact details given on the last page of this manual, and having the system details ready (found on the label inside the TPPR Controller's enclosure).

17.1 Observed Problem

Category	Fault / Problem	Possible Cause	Remedial Action
Configuration	Unexpected timeout during configuration	When you enter the System Setup menu, a 20 minute configuration timeout is active as well as the user login timeout	To avoid this timeout, send a value to the Touchpoint Pro system within the 20 minute period. If the timeout has occurred, it may be necessary to set the module back to Normal state. Navigate to the System Setup screen, select the module and from the Tools menu select Set Normal state. If this was a first time configuration, all data will have been deleted and the channel decommissioned. If you were editing a channel, any data not sent to the Touchpoint Pro system will be lost.
Configuration	'The Network Initialisation failed; the Ring Network is interrupted. Please check the Ring Network wiring and retry the initialisation once the interruption is rectified.'	The system shows the message before reverting to the Tools menu:	Retry the initialisation once the interruption is rectified. Refer to Ring Troubleshooting for further information.
Inhibit Mode	Cannot clear Inhibit from a Channel	It is possible to have more than one inhibit condition active on a channel, and you have to resolve all inhibit conditions before the inhibit can be cleared	Ensure all Inhibits are cleared. Refer to detailed actions below for I/O channels.
I/O channels	Channel / alarm is not functioning as expected	Some parameters may be defined in a different way	Check the definitions of parameters in Commissioning, Channel Configuration and verify settings accordingly.
I/O channels	Cannot clear Auto Inhibit from channel	System has exited configuration unexpectedly, leaving module in configuration state	Navigate to the System Setup screen, select the module and from the Tools menu select Set Normal state. Alternatively go to System Configuration> System Setup. Select one channel of the module, and select Edit Configuration. Close the popup windows and the module will automatically return to Normal state.
Continued...		AIM mV channel has not yet been calibrated	Calibrate the channel. (For catalytic bead type detectors, the Touchpoint Pro controller is necessary to complete the measuring circuit. Therefore all commissioned mV channels remain in Inhibit state until they are calibrated.)

TROUBLESHOOTING

Category	Fault / Problem	Possible Cause	Remedial Action
		Inhibit Delay is active	Wait for the Inhibit Delay time to elapse. (If the Power-On Delay or Fault Recovery Delay is enabled, the system will remain in Inhibit for a period defined by the Inhibit Delay Time.) Please refer to Ch. 9.3.13 Inhibit Delay Settings
		Sensor / Transmitter is signalling Inhibit	The Sensor / Transmitter may be in a start-up sequence, or may have been inhibited for maintenance. Refer to the Input Details for that channel from the Inputs screen.
mA input channel	There is a discrepancy between the sensor reading and the value displayed by Touchpoint Pro	The mA loop requires calibration	Touchpoint Pro converts the 4-20 mA signal it receives from the sensor to a gas reading. If the discrepancy is significant, re-calibrate the 4-20 mA loop by forcing the sensor output to 4 mA then 20 mA, see Commissioning, Calibrating a mA input channel
mA input channel	Error 'Calibration Signal Too High' occurs when calibrating the mA loop	The parameter 'Maximum Span Signal' has been exceeded (default value 20 mA)	Review the configuration of the channel. Under Calibration Settings, verify the value Maximum Span Signal. If necessary, use a lower forced mA value to calibrate the channel. Verify that the transmitter is operating correctly.
mA Input channel	Fluctuating input signal	HART communication with the corresponding field device	HART communication with the field device may appear as a fluctuation on the incoming signal. This will clear when HART communication ceases.
Modbus	No Modbus Communication		Verify that the system has a Bus Interface Board (BIB) fitted. Check the wiring between the Control Module terminal blocks TB6 and TB7 and the host computer system port. Try swapping over TDA and TDB. Check that the serial communication configuration parameters of the host computer system and Touchpoint Pro are the same. Ensure that the bus is correctly terminated. If this is the case remove the bus terminators and retry communication. Consider adding network bias resistors. Please refer to Ch. 11 Configuring Modbus for further details.
Modbus	Communication data errors		Check the data signal wiring is not routed near sources of electrical noise. Check for earth loops. Ensure that the bus is correctly terminated. If this is the case remove the bus terminators and retry communication. Consider adding network bias resistors. If possible use an oscilloscope to examine the signals on the highway and take appropriate corrective action.
Modbus	No response from Touchpoint Pro		Check the address parameter used in requests issued by the host computer system matches the address allocated to the slave node. In multi-drop systems check that all nodes have a unique address.
Module configuration	Module is still showing as present and available for configuration in the System Setup	Module has not been properly removed from the system	Follow the instructions to remove a module from the system, see Maintenance, How to Remove or Decommission an I/O Module

TROUBLESHOOTING

Category	Fault / Problem	Possible Cause	Remedial Action
PC Configuration	No PC Configuration SW connection		Check IP settings, check proper cable connections. The PC should be connected to the Ethernet port of the Touchpoint Pro Control Module. Check that the remote connection port is open. Refer to section 7.5 Enabling TPPER's Remote Connection Port for details.
Ring Fault	Ring Fault Message	Ring circuit fault or Module failure	See Chapter 15 Ring Faults
Ring Oscillation Fault	Ring faults are present or have occurred on the system when commissioning a module or ring circuit.	This may occur when ring wiring faults are present on two or more unconfigured modules, or un-initialised foreign (unrecognised) modules are present on the ring	Remedial action: 1. Check and correct the ring wiring 2. Remove the unconfigured or foreign modules 3. Clear the ring fault from the system 4. Refit the unconfigured or foreign modules in turn and continue with commissioning 5. See Chapter 19 Ring Communication Errors
System	System does not start		Check power supply / wiring, check fuses. Check RCD and UPS/Battery Backup if fitted.
System	Ring communication faults observed		See Chapter 19 Ring Communication Errors Check the Active Events screen for details of the location of the connection break. or Check the LEDs on each Ring Coupling Module (RCM) in the system. The LED flashes to indicate that data is being received, therefore if an LED is not lit, there is a problem in the preceding section of the ring network. LEDs on the Ring coupling module indicate the presence of an incoming signal and they do not take into account the quality of the incoming signal. Check the cables and connections in the area where the fault is indicated.
System	The Event History file is too large to be viewed	The event history file has become too large for the local system memory to process it	Refer to <i>Ch.13.14 Managing the Integral SD Card</i> and replace the SD Card. To view previously stored information, contact your local service representative for help.
System	The system is consistently reporting CCB communication failure	There is a small chance that the CCB has failed	If the problem cannot be remedied by a power cycle, contact your local service representative for help.
System	CCB version mismatch	CCB-M and CCB-R have different firmware versions	1. Ensure both CCBs have the same revision level firmware. 2. Remove CCB with lowest firmware version until replacement can be fitted (Update CCB configuration in controller).
User Interface (Touchscreen)	Lost Admin password	User error	A Honeywell authorised engineer is required to create a new Admin user. Forgotten passwords cannot be recovered.

TROUBLESHOOTING

Category	Fault / Problem	Possible Cause	Remedial Action
User Interface (Touchscreen)	Screen does not respond to touch	Internal communication issue	1) On the front panel, select the Accept and Reset buttons together for >10 s to reset the Communication Board. 2) Contact your service representative if this fails.
User Interface (Touchscreen)	Screen does not respond to user input as expected	Screen calibration	The touch screen may require recalibration.
GUI (Webserver)	'Web browser already open' error message	MS Windows limitation: Browser does not fully shut down on exit, or other instances remain open on exit	Use Task Manager to close the browser or select CTRL+ALT+DEL>Start Task Manager>Processes>[Your browser]>End Process Close Task Manager and relaunch your browser.
Web Server	No Web Server connection		Verify that the TPPR has a valid Webserver licence. Check TCP/IP settings, check if the PC network adapter is enabled, check proper cable connections. The Ethernet port of the Touchpoint Pro Control Module should be connected to a network. Please refer to <i>Ch.5.2 Cabling Requirements</i> for further information.
Web Server	Communication with the Controller is lost	The Touchpoint Pro Controller is busy, or the network has been interrupted.	If possible, check the TPPR Touchscreen for any instruction or detailed error message. A system operation such as power up, backup or restore may be in progress. Allow time for completion and retry.
Web Server	Slow / intermittent response from the Touchpoint Pro system	The Web Server supports 5 concurrent web clients, however it does not restrict further users from connecting	Reduce the number of web clients to five or below.

Table 44. Potential Issues

17.2 Other Issues

17.2.1 Modules Reporting a Fault

If the system detects a module fault, the fault will be reported on the screen and the module's LED will change colour to orange.

If the fault is transient in nature – possibly due to low power supply voltage or to ring communication problems – the module will return automatically to normal operation when the fault is cleared.

When the system detects a module fault, that module will be set to a safe state. If this happens, the module stops communicating on the ring and takes its inputs / outputs to the defined 'safe' state e.g. it turns off mV bead current and takes relays to a power-off state. See *Ch.19 Ring Communication Errors* for further information.

A failed module will generate ring fault reports, module fault reports and channel fault reports. The channels either side of it will also report lost communications, but will not be shown as faulty. See *Ch19.4 Ring Fault Diagnostics and Debugging Techniques* for further information.

The module should only be replaced if the fault is *not* due to low power or a ring problem in another part of the system. Contact your local service representative for help if required.

Note: it may be possible to restore module operation by physically removing and refitting the module to disrupt its power supply. However, you should contact your service representative for advice as the recovery may only be temporary.

POTENTIAL OPERATING ISSUES

18 Error Codes

The TPPER Controller may generate an error message if an exception is encountered. Each message has a code number that is listed, with its explanations and suggested remedy, in the table below.

Key:

CCB = Control Centre Board; **COB** = Communication Board; **I/O** = Input/Output Module; **UDID** = Unique Device Identifier.

Honeywell Service Centre details are on the back page, and your local service contact may be found in:

Configuration Settings>System Status>Tool Box>Global Settings>Service Contact Settings.

Error Code	Message	Possible Cause	Remedial Action	Sys Fail Relay	Sys Fault Relay
1	Not used.	—	—		
2	Operation failed; invalid frame length. Please retry the operation. If the problem persists, please contact your local service representative.	The COB has a communication issue	1. Retry the operation. 2. If still unsuccessful, reboot the COB by pressing [Accept + Reset] for 10 s. 3. If the error still has not cleared, cycle the system power off and on. 4. Contact your local service representative if the problem persists.		X
3	Operation failed; invalid source address. Please verify that the current COB software and CCB firmware revisions are compatible.	A software or firmware update is not compatible with other installed components	1. Refer to the Help screen to confirm the currently installed version of software and firmware. Contact your Service Representative.		X
4	I/O Module parameter write failed; UDID does not match.	The CCB may not recognise the module type	1. Initialise the ring network and try again. 2. If the error persists, contact your Service Representative.		X
5	Not used.	—	—		
6	Operation failed; invalid channel type.	Refer to Error 2	Refer to Error 2		X
7	Operation failed; invalid request type.	————//————	————//————		
8	Operation failed; invalid command code.	Refer to Error 2. Can also occur due to non-compatible COB Software and CCB Firmware versions	————//————		
9	Operation failed; invalid object type.	Refer to Error 2	————//————		
10	Operation failed; invalid object identifier.	————//————	————//————		
11	Operation failed; invalid parameter identifier.	Refer to Error 2. Can also occur due to non-compatible COB Software and CCB Firmware versions	————//————		
12	Operation failed; wrong parameter identifier.	————//————	————//————		

POTENTIAL OPERATING ISSUES

Error Code	Message	Possible Cause	Remedial Action	Sys Fail Relay	Sys Fault Relay
13	Operation failed; parameter is read-only.	Refer to Error 2	————//————		
14	Login session has expired or has been ended by another user.	A user login will time out after 20 minutes of inactivity, or another user may be logged in via one of the alternative interfaces (local Touchscreen or PC Configuration Software)	1. Check if another user is logged in. 2. If your requirement takes priority, you have the option to terminate the existing (other user's) session.		
15	Operation failed; invalid transaction identifier.	Refer to Error 2	Refer to Error 2		
16	Flash memory write operation failed.	During configuration, the CCB was unable to write a value into the non-volatile memory	1. Retry the operation. 2. If the error has not cleared, if possible cycle the power to the system. 3. If the problem persists, please contact your local service representative.	X	X
17	Operation failed; invalid module identifier.	Refer to Error 2	Refer to Error 2		
18	Operation failed; invalid channel identifier.	————//————	————//————		
19	Operation failed; invalid physical channel number.	————//————	————//————		
20	Module ID could not be assigned, because it is already in use by another module.	Each module on the system must have a unique module ID (e.g. M03)	Select a different Module ID		
21	Operation failed; wrong number of parameter identifiers.	Refer to Error 2	Refer to Error 2		
22	Not used.	—	—		
23	Operation failed; Module ID does not exist.	May occur during configuration or changeover of a module	1. Re-initialise the ring network 2. Retry the operation 3. If the error has not cleared, if possible cycle the power to the system. 4. If the problem persists, please contact your local service representative		
24	I/O Module cannot be de-commissioned, because one or more channels on this module are commissioned. Please de-commission all channels before de-commissioning the module.	All channels of a module must be de-commissioned before a module can be de-commissioned	1. De-commission all channels on the I/O Module. 2. Retry the operation.		
25	Operation failed; Module ID does not match.	Refer to Error 23	Refer to Error 23		
26	Operation failed; an I/O Module with the same UDID does already exist on the system.	Each TPPR component has a unique identifying code.	Refer to Error 23 Contact your local representative to obtain a replacement module.		X

POTENTIAL OPERATING ISSUES

Error Code	Message	Possible Cause	Remedial Action	Sys Fail Relay	Sys Fault Relay
27	Operation failed; the intended operation is not allowed for the current I/O Module state.	These errors may occur if configuration of the module or its channels was interrupted, leaving the module in an undetermined state	Depending on the intended operation, either: Restart the configuration for the module, or from the configuration screen, remove the module and restart commissioning, or Force the module to Normal state		
28	The I/O Module could not be found on the network (unknown UDID).	Refer to Error 23	Refer to Error 23		
29	The I/O Module could not be found on the network (unknown SDID).	————//————	————//————		
30	Operation failed; I/O Module state is invalid.	Refer to Error 27	Refer to Error 27		
31	State Change operation failed; could not communicate with I/O Module.	Potential issue with the ring network connection, or damaged/faulty I/O Module	<ol style="list-style-type: none"> 1. Check the Active Events screen for any reported failure of the ring communication. In this case, refer to Error 37 – Ring communication failed. 2. Check that the I/O Module is properly seated on the DIN rail. 3. If the error persists, remove the module and check for any damage to the connector on the DIN rail. 4. In this case, it may be possible to move the module to another slot. 5. If the connector is damaged, contact your local representative to obtain a replacement DIN rail PCB assembly. 6. If no damage is apparent to the connector and the module fails to operate in another slot, then the module may be faulty. Follow the procedure in Maintenance, Replace an I/O Module to replace it. 		
32	The user could not be added. A user with the same name already exists on the system.	User already exists	Create the new user with a different name.		
33	User could not be added; maximum number of 20 users reached.	The system has the maximum number of users	Remove another user so that the new user can be created.		
34	The Username/Password is incorrect, please try again.	Incorrect user name, password or access level	<ol style="list-style-type: none"> 1. Check that the user name and password are correct. 2. Confirm that the user has the required access level (see summary in User Interface, Access Levels). 3. If necessary, create a new user with the appropriate access level. 		
35	The Username/Password is incorrect, please try again.	————//————	————//————		
36	Access denied; your current access level does not allow the intended operation.	————//————	————//————		

POTENTIAL OPERATING ISSUES

Error Code	Message	Possible Cause	Remedial Action	Sys Fail Relay	Sys Fault Relay
37	Ring communication failed - please check proper ring network wiring and try again.	There is an issue with the ring network connection	Refer to Chapter 19 Ring Communication Errors. 1. If the error occurred during normal operation (i.e. not configuration), check the Active Events screen for details of the location of the connection break. 2. Check the LEDs on each Ring Coupling Module (RCM) in the system. The LED indicates that data is being received, therefore if an LED is not lit, there is a problem in the preceding section of the ring network. 3. Check the cables and connections in the area where the connection break fault is indicated.		X
38	System interaction command failed; please try again.	An error occurred during the system interaction	1. Retry the operation. 2. If the error has not cleared, if possible cycle the power to the system. 3. If the problem persists, please contact your local service representative.		
39	Operation failed; wrong alarm identifier.	————//————	————//————		
40	Flash erase operation failed.	The CCB was unable to erase a value from the non-volatile memory	1. Retry the operation. 2. If the error has not cleared, if possible cycle the power to the system. 3. If the problem persists, please contact your local service representative.	X	X
41	Not used.	—	—		
42	Operation failed; maximum file size exceeded.	An error occurred during firmware / software update or configuration backup / restore	1. Check that the correct file is being used for the update / restore operation. 2. Retry the operation. 3. If still unsuccessful, on the front panel, press the Accept and Reset buttons together for 10 s, which will restart the COB. 4. Retry the operation. 5. If the error has not cleared, if possible cycle the power to the system. 6. If the problem persists, please contact your local service representative.		
43	Operation failed; file ID mismatch - firmware update failed.	————//————	————//————		
44	Operation failed; file block out of sequence - firmware update failed.	————//————	————//————		
45	Operation failed; invalid file block size - firmware update failed.	————//————	————//————		
46	Operation failed; CRC mismatch - firmware update failed.	————//————	————//————		
47	Firmware could not be applied - firmware update failed.	————//————	————//————		
48	Configuration restore operation failed.	————//————	————//————		

POTENTIAL OPERATING ISSUES

Error Code	Message	Possible Cause	Remedial Action	Sys Fail Relay	Sys Fault Relay
49	Input channel cannot be de-commissioned, because it is used in the C&E logic. Please remove the input channel first from the corresponding output channel C&E and retry the de-commission operation.	TPPR will not allow the removal of an input from the Cause and Effect matrix	<ol style="list-style-type: none"> 1. Identify the output channel(s) that the input channel is linked to. 2. Modify the Cause and Effect matrix for that channel to remove the input channel. 3. Retry the de-commissioning operation. 		
50	Invalid calibration status.	Channel requires calibration, or has not been successfully calibrated	<ol style="list-style-type: none"> 1. Please retry the operation. 2. If still unsuccessful, on the front panel, press the Accept and Reset buttons together for 10 s, which will restart the COB. 3. If the error has not cleared, if possible cycle power to the system. 4. Contact your local Service Representative if the problem persists. 		
51	Zero gas calibration failed - zero signal too low.	The level at which the channel is trying to calibrate zero is outside the configured limits	<ol style="list-style-type: none"> 1. For a mA channel, calibration should always be done by forcing the output from the sensor where the facility exists. Check the configured limits on zero and span gas calibration and ensure that the forced mA value is within the limits. 2. For a mA channel where the sensor has no facility to force the output, consult the manufacturer's instructions and carry out a calibration at the sensor. 3. For a mV channel, there may be a problem with the sensor or the calibration gas. Consult the manufacturer's instructions. 4. Contact your local Service Representative if the problem persists. 		
52	Zero gas calibration failed - zero signal too high.	The level at which the channel is trying to calibrate zero is outside the configured limits	<p style="text-align: center;">—————//—————</p>		
53	Span gas calibration failed - span signal too low.	The level at which the channel is trying to calibrate span is outside the configured limits	<p>As above.</p> <p>If carrying out a cross calibration, check the calculated figure using the sensor documentation.</p>		
54	Span gas calibration failed - span signal too high.	The level at which the channel is trying to calibrate span is outside the configured limits	<p>As above.</p> <p>If carrying out a cross calibration, check the calculated figure using the sensor documentation.</p>		
55	Gas calibration failed - sensor lifetime exceeded. The sensor sensitivity has fallen to below 50% of its original value; please replace the sensor.	TPPR monitors the performance of mV sensors relative to their first span calibration. If the gas response falls below 50% of the original value this error occurs.	<ol style="list-style-type: none"> 1. Contact your local service representative to schedule a sensor replacement. 2. When the replacement sensor has been fitted, repeat calibration in accordance with the instructions in chapter 6, using the 'First Span' function. 		

POTENTIAL OPERATING ISSUES

Error Code	Message	Possible Cause	Remedial Action	Sys Fail Relay	Sys Fault Relay
56	Entered span gas concentration is out of range - please edit and try again	The span gas selected is not within the configured limits	<ol style="list-style-type: none"> 1. Check the configured limits for span gas concentration. 2. Obtain an alternative span gas that is within the limits. 3. Retry the operation. 		
57	Operation failed; invalid object type	There has been a communication error between the CCB and COB	<ol style="list-style-type: none"> 1. Please retry the operation. 2. If still unsuccessful, on the front panel, press the Accept and Reset buttons together for 10 s, which will restart the COB. 3. If the error has not cleared, if possible cycle the power to the system. 4. If the problem persists, please contact your local service representative. 		X
58	Operation failed; CRC calculation timeout	There has been a file transfer error between the CCB and COB	<ol style="list-style-type: none"> 1. Please retry the operation. 2. If still unsuccessful, on the front panel, press the Accept and Reset buttons together for 10 s, which will restart the COB. 3. If the error has not cleared, if possible cycle the power to the system. 4. If the problem persists, please contact your local service representative. 		X
59	Operation failed; a session has already been opened by another user	Another user may be logged in via one of the alternative interfaces (local Touchscreen or PC Configuration Software)	<ol style="list-style-type: none"> 1. Check if another user is logged in. 2. If your requirement takes priority, you have the option to terminate the existing (other user's) session. 		
60	The session has expired - new user login required	A user login will time out after 20 minutes of inactivity	The system will automatically request a new login		
61	Not used	—	—		
62	Not used	—	—		
63	Operation failed; CRC error occurred for safe data.	Refer to Error 2	Refer to Error 2	X	X
64	Operation failed; CRC error occurred for non-safe data.	————//————	————//————		X
65	Operation failed; session does not exist; user login required	User login is required before carrying out the intended operation	The system automatically requests a new login. The user may have been remotely logged out by another user.		
66	Operation failed; CCB did not respond within the expected time interval.	Refer to Error 2	Refer to Error 2		
67	Configuration read / write request failed; FLASH memory operation timeout	During configuration, the CCB was unable to read or write a value from / to non-volatile memory	<ol style="list-style-type: none"> 1. Retry the operation. 2. If the error has not cleared, if possible cycle the power to the system. 3. If the problem persists, please contact your local service representative. 	X	X

POTENTIAL OPERATING ISSUES

Error Code	Message	Possible Cause	Remedial Action	Sys Fail Relay	Sys Fault Relay
68	The Network Initialisation failed; the Ring Network is interrupted. Please check the Ring Network wiring as explained in the user manual and retry the initialisation once the interruption is rectified.	The system will not allow you to initialise the network if a ring break is present	See Chapter 19 Ring Communication Errors 1. Check the Active Events screen for details of the location of the connection break. 2. Check the cables and connections in the area where the connection break fault is indicated (also see Error 37). 3. Ensure that details of the Ring Network break error have gone from the Active Events screen (problem is resolved) 4. Return to the System Setup screen and retry the Ring Initialisation operation.		
69	Not used	—	—		
70	Cannot clear Inhibit because the channel has been inhibited automatically	A mV input channel has not yet been calibrated or channel configuration was interrupted, or the inhibit delay time is active, or the sensor/transmitter is signalling inhibit	1. For a mV channel, calibrate the channel (see Commissioning, Calibrating a mV input channel). 2. If this is not the cause, go to System Configuration, then System Setup. 3. Select the module with the inhibited channel, and select Normal State. 4. If this is not successful, go to Tool Box then Event History to check if an Inhibit Delay Time is active. The inhibit condition will clear after the Delay Time has expired. 5. If there is no Delay Time active, then investigate the conditions at the sensor/transmitter.		
71	Cannot reset because the alarm, fault or warning is still active	The field device is still signalling an active alarm, fault or warning	Investigate the conditions at the field device.		
72	One or more events are still active and cannot be reset	Cleared alarms, faults or warnings have been reset, but others are still active	Some events (for example Over Range Warning) may give multiple alarms and these must all be investigated and cleared at the respective field devices before attempting to reset again.		
73	Replace operation cannot be performed; module type of new module is not compatible.	Replacement module is incorrect type or not recognised by the CCB	1. Check and confirm that the replacement module is of the correct type. 2. Re-initialise the ring network and try again. 3. If the error persists, update the CCB firmware. 4. If the problem persists, please contact your local service representative.		
74	Not used	—	—		
75	Not used	—	—		
76	Not used	—	—		
77	Not used	—	—		
78	Not used	—	—		

POTENTIAL OPERATING ISSUES

Error Code	Message	Possible Cause	Remedial Action	Sys Fail Relay	Sys Fault Relay
79	The Input Module cannot be commissioned: The maximum number of 16 Input Modules has already been commissioned on the system.	TPPR has a maximum capacity of 16 Input and 32 Output Modules	If more channels than 64 inputs and 128 outputs are required an additional TPPR system is needed. Contact your local representative to discuss your requirements		
80	The Output Module cannot be commissioned: The maximum number of 32 Output Modules has already been commissioned on the system.	————//————	————//————		
81	Invalid test sequence	CCB receives wrong Test sequence for Relay tests	Refer to Error 2		
82	The user could not be added; invalid user name. Please choose a different user name and try again.	The user name must be 4 to 20 characters long	Please choose a user name that meets the requirements and try again		
83	Kill Session denied Configuration Backup / Restore in Progress	User has attempted to end a session for the PC configuration SW while a CCB configuration backup or restore is in progress	Retry after the configuration restore operation is completed. Check with the user at the local controller that it is acceptable to log in from remote PC.		
84	Kill Session denied CCB Firmware update in Progress.	User has attempted to end a session for the PC configuration SW while a CCB firmware update is in progress	Retry after the firmware download operation is completed. Check with the user at the local controller that it is acceptable to log in from remote PC.		
85	The controller needs a restart to proceed further. Please power cycle the controller and try again.	The system is being updated and needs a power cycle to continue.	Cycle the power supply off, wait 15 to 20 seconds and then power on again		
86	System is running in test mode.	One of the three test modes is active, and other operations are restricted or not permitted	Wait until testing is complete. If necessary, exit Test Mode to carry out the required operation.		X
87	Not used	—	—		
88	Operation failed; Save Calibration Failed.	TPPR was unable to save the sensor calibration	Please retry the operation.		
89	Operation failed; Channel Wiring Fault.	TPPR cannot detect that a sensor is connected to the channel or it has detected incorrect wiring	Check all field wiring to the sensor and correct any problems		X
90	Operation failed; Bead Fault.	TPPR cannot read the bead current from the connected mV sensor	Check all field wiring to the sensor. It is possible that the sensor has failed, Refer to the manufacturer's instructions		X

POTENTIAL OPERATING ISSUES

Error Code	Message	Possible Cause	Remedial Action	Sys Fail Relay	Sys Fault Relay
91	Operation failed; system is running in test mode.	One of the three test modes is active, and other operations are restricted or not permitted	Wait until testing is complete. If necessary, exit Test Mode to carry out the required operation.		
92	Calculation error	A calculation error has occurred during calibration, for example Zero and SPAN calibration done with the same gas input	Retry the calibration. Ensure that the values for zero and span gas are entered correctly.		
93	Operation failed; module list is mismatching	The Module list detected and the Module list in Backup file are not the same	Ensure that the correct backup file for the system is being used. Retry the operation.		
94	Operation failed; please perform ring initialisation first	Faulty CCB has been replaced by new CCB and configuration restore has been attempted	First initialise the ring network, then try again		
95	The username/password is incorrect, please try again	User credential mismatch	Verify user name and password and try again. Usernames and passwords are case sensitive.		
96	Not used	—	—		
97	Cannot open session because a channel is being calibrated	A user at the local Touchscreen is doing calibration when a PC Configuration Software user tries to open a configuration session	Wait for the calibration to be completed. Check with the user at the local controller that it is acceptable to log in from remote PC.		
98	Cannot start calibration because a configuration session on PC is in progress	Calibration is attempted while a configuration session is in progress	Close the configuration session and retry calibration. Contact the remote user to agree access.		
99	Operation failed; Brownout Fault	Brown out fault (low power supply voltage) is set for a module and configuration is attempted for this module / channels of module	Check that power supply voltage is correct, and that current limit is adequate. Remedy the fault and then do configuration.		X
100	Replace operation cannot be performed - no free I/O Modules available. Please add a compatible I/O Module and initialize the ring network again.	The replacement module has not been detected on the network	Refer to section Maintenance, Replacing an I/O Module for the full procedure.		
101	Ring initialisation has failed. Please cycle the power to the system	Ring Network Initialisation has failed	1. Power cycle the TPPR system 2. Return to the System Setup screen and retry the Ring Initialisation operation.		
102	Initialisation timeout has occurred. Please cycle the power to the TPPR system.	An internal system timeout has occurred	Power cycle the TPPR system		

POTENTIAL OPERATING ISSUES

Error Code	Message	Possible Cause	Remedial Action	Sys Fail Relay	Sys Fault Relay
103	Not used	—	—		
104	Operation failed; response result failure	Internal communication error	<ol style="list-style-type: none"> 1. Please retry the operation. 2. If still unsuccessful, on the front panel, press the Accept and Reset buttons together for 10 s, which will restart the COB. 3. If the error has not cleared, if possible cycle the power to the system. 4. If the problem persists, please contact your local service representative. 		
105	Operation failed; response timeout	—//—	—//—		
106	Operation failed; CRC error	—//—	—//—		
107	Operation failed; session expired	A user login will time out after 20 minutes of inactivity	The system will automatically request a new login		
108	CCB-COB communication failed.	Refer to Error 2	Refer to Error 2		X
109	Operation failed; CCB is not responding.	—//—	—//—		X
110	Channel cannot be commissioned; no free Channel ID available.	Each TPPR system is limited to 64 input and 128 output channels maximum	Contact your local representative if you want to discuss any requirements above this limit.		
111	Operation failed; invalid command code received from CCB.	Refer to Error 2	Refer to Error 2		
112	Module cannot be commissioned. You have exceeded the maximum number of 48 I/O modules. Use the Remove Module or Replace Module function in the System Configuration.	Each TPPR system is limited to 16 Input plus 32 Output Modules maximum	Contact your local representative if you want to discuss any requirements above this limit.		
113	Not used	—	—		
114	Restore operation failed - backup file could not be found	An error occurred during configuration restore	<ol style="list-style-type: none"> 1. Check that you have specified the correct memory device, SD or USB. 2. Check that the correct file is being used for the restore operation, and is saved as \Hard Disk\TPPR Configuration\TPPR_Config_<SystemID>_<nnn>.bin, where nnn is 001 to 999 3. Retry the operation. 4. On the front panel, press the Accept and Reset buttons together for 10 s, which will restart the COB. 5. Retry the operation. 		
115	Operation cannot be performed - please insert SD Card!	—	<ol style="list-style-type: none"> 1. Check that the SD Card has enough free memory available for the operation. 2. Check that it is correctly inserted in the socket. 3. Retry the operation. 		X

POTENTIAL OPERATING ISSUES

Error Code	Message	Possible Cause	Remedial Action	Sys Fail Relay	Sys Fault Relay
116	Operation failed; transaction could not be closed	Refer to Error 2	Refer to Error 2		
117	Operation failed; response parsing failure	————//————	————//————		
118	The System ID has not been programmed. Contact your system administrator or service centre.	The System ID is not stored in the system.	1. Locate and re-enter the correct System ID. 2. Allocate and enter an ID if none allocated. Default is controller serial number. (Administrator access is required for both.) 3. Contact your service representative. The gas detection system will continue to work correctly, but backups cannot be restored until the correct System ID is programmed.		
242	The channel has reported a fault	Clear the fault and try again	Clear the fault and try again		
245	Operation Failed – fault recovery delay is active	Sensor is still warming up	Retry after sensor fault recovery delay has timed out.		
246	Operation Failed – power-up delay is active	Sensor is still warming up	Retry after sensor power up delay has timed out.		
247	Operation Failed – module is in configuration state	Timeout while editing configuration	Navigate to System Setup screen and set module to Normal state from menu.		X
249	Not used	—	—		
250	Operation failed; kill session denied as CCB is busy performing critical operation	A user has attempted to end a session while the CCB is updating memory as result of a configuration request	Try again after the memory update is completed. Check with the user at the local controller that it is acceptable to log in from remote PC.		
252	Operation failed; Redundant CCB failed; power cycle the controller and try again	Redundant CCB failed during firmware update	1. Replace the CCB-R. 2. Remove failed CCB until replacement can be fitted. (Update CCB configuration in controller.) 3. Contact your local service representative.		X
253	STEL timer is reset by this operation	Channel inhibit resets the STEL time-weighted average calculations	This is a warning message to notify the user that the STEL calculation is resetting		
254	Not used	—	—		
255	Operation failed	—	Retry the operation. If the problem persists, contact your local service representative.		
400	Unknown error code received from CCB. Please retry the operation. If the problem persists, please contact your local service representative	—	Please retry the operation. If the problem persists, please contact your local service representative.		X

Table 45. Error Codes and Remedies

POTENTIAL OPERATING ISSUES

19 Ring Communication Errors



WARNING

A ring communication error or fault warning could signify the loss of communication with number of sensors connected to the affected module(s). Always consider putting in place alternative safety arrangements while the fault is investigated.

Ring communication is controlled by the CCB and has redundancy, which means that a single communication fault will not jeopardise the whole system. The system shows the failure position, as illustrated in the fault cases described below.

Note: Any situation that prevents correct CCB operation may also prevent correct ring operation. Resolve any CCB problems before troubleshooting ring operation.

Ring faults may occur for two reasons: either due to a faulty module or due to ring bus electrical/wiring faults.

19.1 Module Faults

Modules are designed to periodically self-test and will shut down if they detect a fault or suffer a catastrophic failure, and they will stop communicating on the ring circuit. This will typically be reported as a ring fault in addition to a module fault.

In the event of a module shut-down, modules either side of the faulty module will divert communication from the primary circuit (Ring A) to the secondary circuit (Ring B), and will report Ring faults. In addition, all commissioned channels on the faulty module will report a channel fault. The remaining modules and channels will continue to work correctly.

The table extract below is from an actual event log and it shows that Module M23 has failed.

M23	16/11/2015 12:34:52	Module M23	Module M23-Ring	System Fault
o061	16/11/2015 12:34:52	<Ch Tag>	Ring Communication Error	Fault
o062	16/11/2015 12:34:52	<Ch Tag>	Ring Communication Error	Fault
o063	16/11/2015 12:34:52	<Ch Tag>	Ring Communication Error	Fault
o064	16/11/2015 12:34:52	<Ch Tag>	Ring Communication Error	Fault
	16/11/2015 12:34:53	System Fault	Ring : Module M22	System Fault
	16/11/2015 12:34:53	System Fault	Ring : Module M24	System Fault

Table 46. Example of a Ring Fault Event Log

The table above indicates that Module M23 to the Ring is causing Ring Communication Errors and that the Ring circuits are broken between Modules M22 and M24. The event display would be similar if the faulty module is the first or last module on the Ring, but it might also indicate a ring fault between the module and the CCB.

Note: Channels associated with a faulty module will also be reported as faulty, but these events may be ignored as the parent module has shut-down and is unable communicate any channel data.

19.2 Troubleshooting Module Faults First Response

If a Module Fault is reported, you may first try removing and then refitting the affected module to see if this clears the fault, or you can try doing a full system power cycle. Be aware, though, that an apparent fix may be temporary and the fault may recur if the module itself has a transient fault.

Note: All Ring failures should be investigated to avoid unplanned recurrences.

POTENTIAL OPERATING ISSUES

19.3 Troubleshooting Module Faults Second Response

If the first response fails, Ring operation may be restored by physically removing a faulty module. However, the system will continue to report the module and its channel as faults (unless the channels are inhibited).

In the unlikely event of multiple module failure, any modules between the faulty modules will be hidden from the controller. If this happens you can remove faulty modules from the backplane to restore communication to the remaining modules. (It is not necessary to remove backplane power when disconnecting and replacing modules, but troubleshooting and repairs should only be done by qualified persons).



WARNING

Removing a module will render its channels inoperative, so you must make alternative safety arrangements until the module is replaced and its channels reconfigured and recalibrated.

19.3.1 Ring Wiring Faults

Ring wiring faults will typically be reported by the system during initial commissioning (due to faulty module insertion or faulty wiring etc.), or as a result of physical damage or disturbance in the ring bus possibly caused during module removal or fitting.

19.3.2 RCM Faults

Where a fault is reported between the CCB and the first or the last module, the system cannot identify whether the error is between the CCB and the RCM, or between the RCM and the module, or in the RCM itself. In practice faults are most likely to be in the wiring between TB2/TB3 and the RCM(s).

19.3.3 Ring Terminals

Ring terminals are defined as (Ring) A-in, A-out, B-in and B-out (see *Ch. 5.4.1 Ring Wiring* for further details).

19.3.4 Ring Faults on Initial Commissioning

At initial commissioning the system will typically report a ring fault or ring oscillation if a fault is already present. If this happens:

- For new installations, visually check that all module LEDs are green and flashing.
- Visually check the two ring LEDs on each RCM. They should be flashing alternately at the same rate. On most systems the corresponding CCB LEDs may be checked through a hole at the left edge of the controller's back cover.
- Visually check that the power LED on each module is illuminated. If not illuminated, check that backplane power is present and that the module is correctly fitted on the backplane connector.
- Initialise the ring to ensure that all modules are responding and/or to localise the faulty area. The system will list all detected modules in the System Setup screen.
- Check that each module is shown, and that the order is correct. (Uncommissioned modules will be listed in the order that they are connected – following the order of the A ring – but the order will change when they are commissioned.)
- Check for obvious wiring faults and check that screw terminals are correctly tightened.
- If ring oscillation is observed, check for correct circuit wiring, e.g. that B-out isn't incorrectly connected to RCM B-in, or that wiring isn't crossed or shorted between the A and B rings.
- Try removing most of the modules from the backplane to help distinguish between Wiring and Module faults – a backplane with only an RCM fitted will operate over short wiring distances but at least one IO module must be fitted to each backplane for normal operation over longer distance.

POTENTIAL OPERATING ISSUES

19.3.5 Ring Faults on Commissioned Systems

On Commissioned systems the CCB will attempt to identify the approximate location of a ring break, and will attempt to identify the modules either side of the break.

If the system cannot communicate with a module by either the A ring or the B ring, the module and its channels will be shown as faulty. A large number of fault messages may be reported if several modules are affected.

If the Location message merely says 'Ring A Fault' or 'Ring B Fault', remove any un-initialised modules and recheck the events log before starting fault diagnosis.

Ring faults on a commissioned system may be the result of recent system changes, disturbance, or damage so:

- Review the Active Events screen for information.
- Review the System Setup screen and check for unexpected module states.
- To help locate ring breaks visually check the power and ring LEDs as described for Ring Faults on Initial Commissioning.
- Visually check any *empty* backplane slots to ensure that they were not damaged during previous work, then test from the named faulty module towards the CCB (i.e. reverse the circuit arrows shown in the figures).
- Check that modules and connectors are correctly fitted and that all screw terminals are correctly tightened.

Note: The fault message term 'before' is relative to the communication Ring A / Ring B direction as shown in the figures.

19.3.6 Spurious Fault Reporting

Due to external factors some reported faults may be spurious, variable or unstable, typically showing high numbers of faults that are difficult to locate or diagnose. E.g. if a short or open circuit occurs in a remote location the communication ring may appear to operate normally or ring operation and fault reporting may be intermittent and transient. These faults can be difficult to diagnose, especially if a cable has degraded over time and/or where moisture ingress may be a factor.

If in doubt:

- Check if the occurrences correspond to ambient conditions such as rain, high humidity or dew point.
- Check the connections and wiring at remote cabinets and cable joints, and then work backwards toward the Controller while checking for degraded, damaged or shorted wiring, particularly within exposed cable runs.

19.4 Ring Fault Diagnostics and Debugging Techniques

Key to Figures:

A = Ring A Circuit

B = Ring B Circuit

CCB = Control Central Board

RCM = Ring Coupling Module

M1 etc. = Modules. (Configured Modules may have local or descriptive IDs that are not shown here.)

19.4.1 Ring Fault Type 1

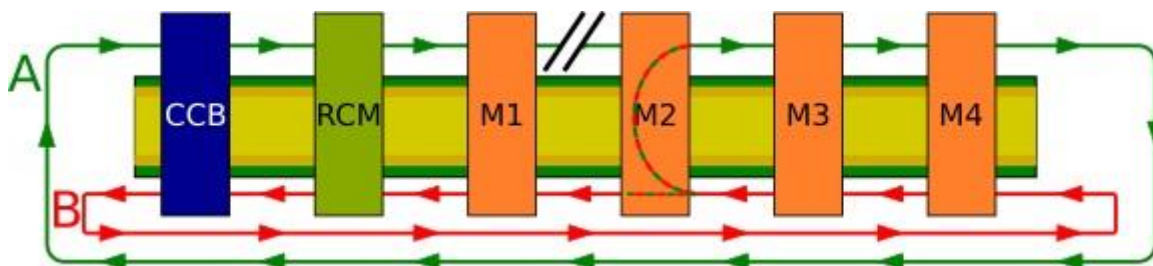

Figure 98. Ring Fault Type 1

Rationale:

If a Ring A connection is faulty (e.g. between M1 A-out and M2 A-in) then Module 2 will not receive a signal from 'A-in' so this module will loop back the data from Ring B onto Ring A. The CCB will register that Module 2 has looped the data back and will tell the UI to show a fault message for 'Ring A : Module 2'.

Investigation:

Check the Ring A circuit before the named module (e.g. M1 to M2 in this example).

POTENTIAL OPERATING ISSUES

19.4.2 Ring Fault Type 2

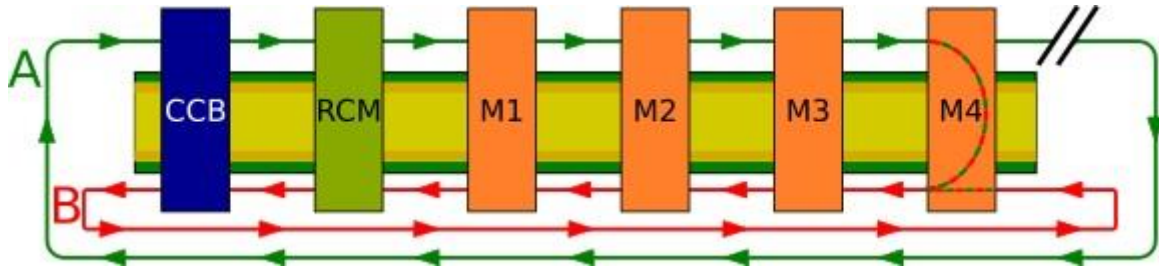

Figure 99. Ring Fault Type 2

Rationale:

If a Ring A circuit is faulty (e.g. between last module A-out and the CCB A-in) then the CCB Module 4 will loop back the data from Ring A onto Ring B, and will tell the UI to show a fault message for 'Ring A fault before CCB'.

Investigation:

Check the Ring A circuit from the last module A-out to the CCB A-in.

19.4.3 Ring Fault Type 3

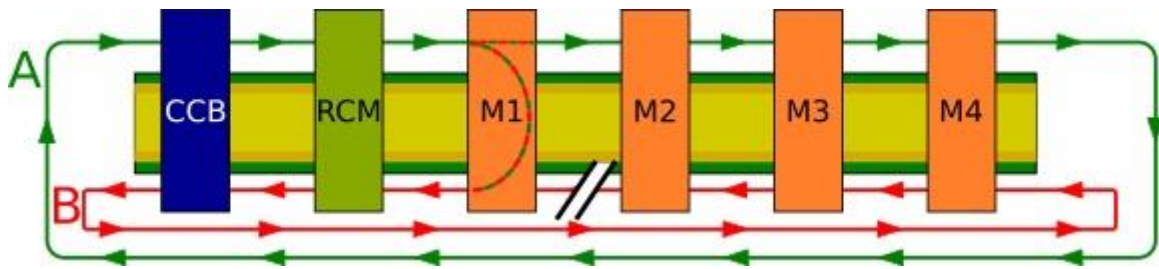

Figure 100. Ring Fault Type 3

Rationale:

If a Ring B circuit is faulty (e.g. between M1 B-in and M2 B-out) then Module 1 will not receive B-in and this module will loop back the data from Ring A onto Ring B. The CCB will have both A-in and B-in but no B-out, and will tell the UI to show a fault message for 'Ring B : Module 1' to show that the fault lies between M1 and M2.

Investigation:

Check the Ring B circuit from M1 B-in to M2 B-out.

19.4.4 Ring Fault Type 4

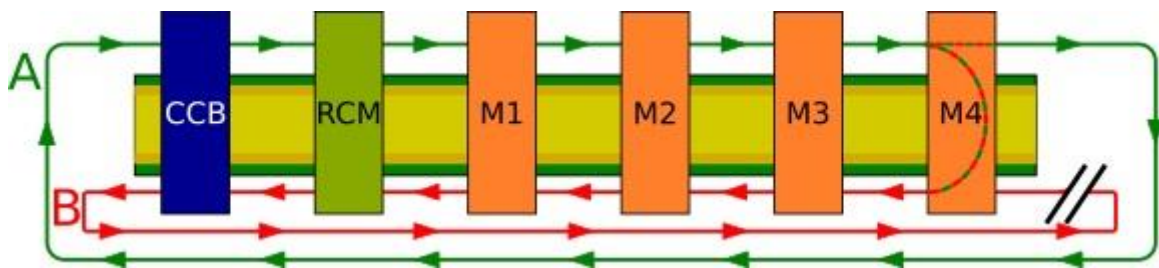

Figure 101. Ring Fault Type 4

Rationale:

If a Ring B circuit is faulty (e.g. between M4 B-in and CCB B-out) then Module 4 will loop back the data from Ring A onto Ring B, and the CCB will tell the UI to show a fault message for 'Ring B : Module X' (where X is the last module in the chain).

Investigation:

Check the Ring B circuit from CCB B-out to the last module B-in.

POTENTIAL OPERATING ISSUES

19.4.5 Ring Fault Type 5

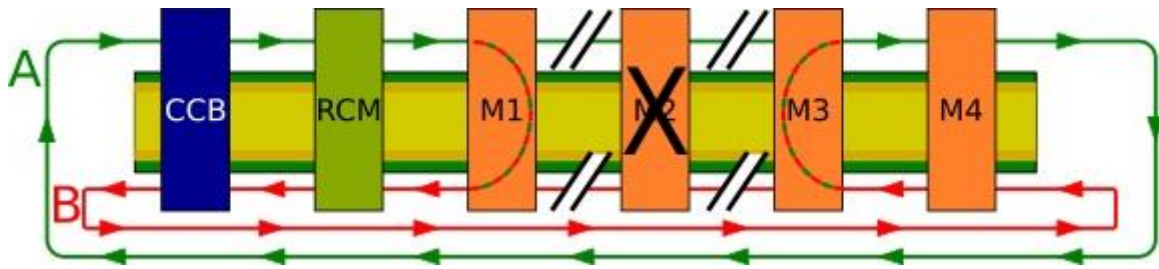

Figure 102. Ring Fault Type 5

Rationale:

If a Module fails both ring networks are interrupted but fail 'safe'. In the example above Module 3 will loop back the data from Ring B onto Ring A and Module 1 will loop back the data from Ring A onto Ring B, causing the CCB to tell the UI to show a fault message for both 'Ring : Module 1' and 'Ring : Module 3'.

Investigation:

First check the circuit between these two module locations. Also check the empty slots on the DIN rail between these locations.

If these checks are Ok, replace the suspect module, reconfigure and retest the system.

19.4.6 Ring Fault Type 6

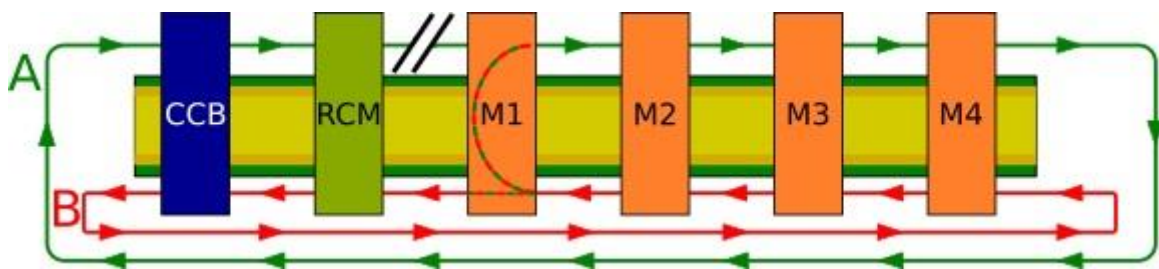

Figure 103. Ring Fault Type 6

Rationale:

If a Ring A circuit is faulty (e.g. before Module 1), then Module 1 will not receive A-in and will loop back the data from Ring B onto Ring A, and the CCB will tell the UI to show a fault message for 'Ring A : Module 1'.

Investigation:

Check the Ring A circuit (e.g. RCM A-out to M1 A-in) before the notified module.

19.4.7 Ring Fault Type 7

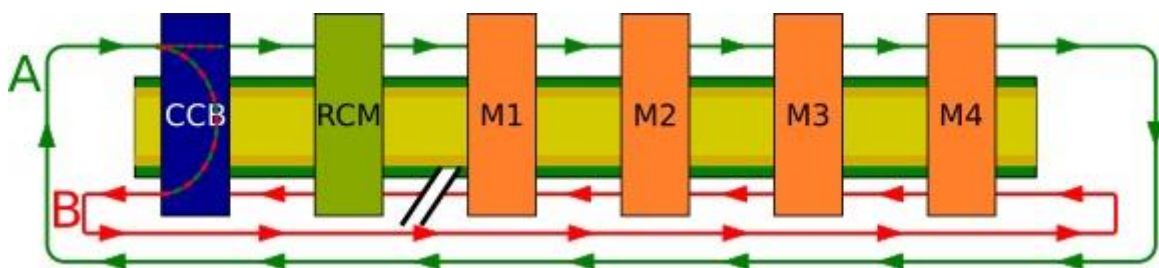

Figure 104. Ring Fault Type 7

Rationale:

If a Ring B circuit is faulty (e.g. before the CCB), then the CCB will not receive B-in and it will tell the UI to show a fault message for 'Ring B fault before CCB'.

Investigation:

Check the Ring B circuit from the first module to the CCB.

HELP AND TRAINING

20 Further Assistance and Training

It is not always possible or desirable to include all of the possible technical or Help issues in a freely available document so Honeywell has a team of dedicated technical specialists on call to handle technical support or general help issues that are not covered in this guide, and who can help you to organise User or Field Service **Engineer** training if required.

For further assistance, contact Honeywell Analytics technical support (see back page).

Please have the following information to hand:

- A description of the problem, including the error code and any steps you have taken to resolve it.
- The serial number of the TPPR system.
- CCB firmware version.
- COB firmware version.
- Local UI version.
- Webserver version.
- Modbus version (if applicable).

You can find the information above by selecting **Tool Box>Help>About**.

Note: In addition to basic and advanced TPPR training, Honeywell training can include the installation and testing of Honeywell sensors and detectors.

TECHNICAL SPECIFICATIONS

21 TPR Specifications

This section contains basic information about the various TPR major equipment and assemblies, and the terms 'Local' and Remote' refer to the unit's physical location in relation to the control room.

Note 1: Power Supply Fluctuations are not to exceed DC 18 – 32 V SELV Supply or $\pm 10\%$ of nominal.

Note 2: All equipment in this manual is rated to +2000 m (6562 ft.) altitude maximum.

Note 3: All rack-mounted enclosures are Equipment Class 1 (grounded) and Installation Category 2.

21.1 Rack Mounted Equipment



WARNING

This apparatus must be installed in a suitable enclosure which provides a Pollution Degree 2 environment in ordinary (safe area) locations.

AVERTISSEMENT

Cet appareil doit être installé en zone sûre dans un boîtier conforme au niveau 2 de pollution environnementale.



WARNING

This apparatus must be installed in a suitable enclosure which provides at least IP20 / Type 1 to mitigate the risk of electrical shock.

21.1.1 OEM 19 inch 5U Assembly (Local)

Front Panel Controller, which includes mounting brackets, UI, PCBs and SD Card.

Part Number	TPPR-V-0602
Material	Mild Steel
Earth (Ground) Points	M8 (main grounding) other M6
Dimensions (H x W x D)	483 x 222 x 110 mm
Weight	12 Kg with controller assembly; 6 Kg without
Electrical Rating	24 VDC nominal (18 – 32 VDC); 13 W max. (W max is dependent on module and PSU configuration.)
Relay Contacts	250 VAC; 50/60Hz; 30 VDC; 5 A max.
Class	Equipment Class 1 (grounded)
Altitude	2000 m ASL max. in permanently-connected continuous operation.
Pollution Degree	2
Ambient Temperature	-20 °C to +65 °C
Humidity	10 to 90 %RH non-condensing
Ingress Protection	N/A (See below for special considerations*)

***Note:** to maintain the Type 1 and IP 2X ratings this panel must be fitted to an equivalent certified rack enclosure designed for use with this front panel with no more than a 6 mm gap that provides a Pollution Degree 2 environment when fitted together in accordance with the manufacturer's instructions. It is the end user's responsibility to ensure that the rack system meets all relevant approvals, including ensuring adherence to temperature ratings when installed in the end unit/system.

TECHNICAL SPECIFICATIONS

21.1.2 Rack Unit Model 19 inch 5U Assembly (Local or Remote)

Supplied with a PSU and Modules; Local with a Controller, PCBs and SD Card.

Part Number	TPPR-S-XXXX
Material	Mild Steel
Earth (Ground) Points	M8 (main grounding) other M6
Dimensions (H x W x D)	483 x 222 x 110 mm
Weight	12 Kg with interface, 6 Kg without
Electrical Rating	100 – 240 VAC ($\pm 10\%$ of nominal supplied voltage), 50/60 Hz, 5 A max, Power Factor > 0.9 or 24 VDC nominal (18 – 32 VDC) 20 A max. (W max is dependent on subsequent module and PSU configuration.)
Class	Equipment Class 1 (grounded)
Altitude	2000 m ASL max. in permanently-connected continuous operation.
Pollution Degree	2
Ambient Temperature	–40 °C to +70 °C max. –20 °C to +65 °C (Local with Controller) –25 °C to +65°C (70 °C de-rated) (Remote with PSU but no Controller)
Humidity	10 to 90 %RH non-condensing
Ingress Protection	Type1 / IP2X*

***Note:** to maintain the Type 1 and IP 2X ratings this panel must be fitted to an equivalent certified rack enclosure designed for use with this front panel with no more than a 6 mm gap that provides a Pollution Degree 2 environment when fitted together in accordance with the manufacturer's instructions. It is the end user's responsibility to ensure that the rack system meets all relevant approvals, including ensuring adherence to temperature ratings when installed in the end unit/system.

21.1.3 OEM Unit 5U Assembly Only

Front Panel Controller, which includes UI, PCBs and SD Card but no mounting brackets.

Part Number	TPPR-V-0852
Material	Mild Steel w. Membrane panel
Earth (Ground) Points	M8 (main grounding) other M6
Dimensions (H x W x D)	225 x 360 x 70 mm
Weight	4 Kg
Electrical Rating	24 VDC nominal (18 – 32 VDC); 13 W max. (W max is dependent on subsequent module and PSU configuration.)
Relay Contacts	250 VAC; 50/60Hz; 30 VDC; 5 A max.
Class	Equipment Class 1 (grounded)
Altitude	2000 m ASL max. in permanently-connected continuous operation.
Pollution Degree	2
Ambient Temperature	–20 °C to +65 °C
Humidity	10 to 90 %RH non-condensing
Ingress Protection	N/A (See below for special considerations*)

***Note:** to maintain the Type 1 and IP 2X ratings this panel must be fitted to an equivalent certified rack enclosure designed for use with this front panel with no more than a 6 mm gap that provides a Pollution Degree 2 environment when fitted together in accordance with the manufacturer's instructions. It is the end user's responsibility to ensure that the rack system meets all relevant approvals, including ensuring adherence to temperature ratings when installed in the end unit/system.

TECHNICAL SPECIFICATIONS

21.2 Wall Mounted Enclosures



WARNING

Protect the User Interface from direct exposure to precipitation and sunlight.

AVERTISSEMENT

Protéger l'interface utilisateur des expositions directes au soleil et de la pluie.

21.2.1 Wall Mount Controller Enclosures with User Interface

These units can be installed indoors or outdoors in a Pollution Degree 3 environment, but one which affords total protection from rain, snow and direct UV rays (sunlight).

Part Number	TPPR-V-1210	TPPR-V-1220	TPPR-V-1230
Material	Mild Steel	Mild Steel	Mild Steel
Dimensions (H x W x D)	600 x 600 x 300 mm	800 x 600 x 300 mm	1200 x 800 x 300 mm
Weight	37 Kg	46 Kg	81 Kg
Electrical Rating	100 – 240 VAC; 50/60 Hz; 1250 W max or 24 VDC nominal (18 – 32 VDC); 1500 W max. W max is dependent on module and PSU configuration.		
Class	Equipment Class 1 (grounded)		
Altitude	2000 m ASL max. in permanently-connected continuous operation.		
Pollution Degree	3		
Ambient Temperature	-20 °C to +55 °C		
Humidity	10 to 100 %RH condensing		
Ingress Protection	Type 4, 12 / IP66		

21.2.2 Wall Mount Remote Unit Enclosures without User Interface

These units can be installed indoors or outdoors in a Pollution Degree 4 environment, and can be exposed to rain, snow and direct sunlight.

Part Number	TPPR-V-1215	TPPR-V-1225	—
Material	Mild Steel	Mild Steel	—
Dimensions (H x W x D)	600 x 600 x 300 mm	800 x 600 x 300 mm	—
Weight	37 Kg	46 Kg	—
Electrical Rating	100 – 240 VAC; 50/60 Hz; 1250 W max or 24 VDC nominal (18 – 32 VDC); 1500 W max. W max is dependent on module and PSU configuration.		
Class	Equipment Class 1 (grounded)		
Altitude	2000 m ASL max. in permanently-connected continuous operation.		
Pollution Degree	4		
Ambient Temperature	-25 °C to +55 °C (Remote version with PSU's) or -40 °C to +55 °C max.		
Humidity	10 to 100 %RH condensing		
Ingress Protection	Type 4, 12, 13 / IP66		

TECHNICAL SPECIFICATIONS

21.2.3 Zone 2 Division 2 Remote Wall Unit Enclosure without User Interface



WARNING

Do not open when a flammable gas atmosphere is present.
(Class 1 Div.2, Class 1 Zone 2, and Zone 2 [ATEX])

AVERTISSEMENT

Ne pas ouvrir l'équipement dans des atmosphères contenant des gaz inflammables.
(Classe 1 Div.2, Classe 1 Zone 2, et Zone 2 [ATEX])



WARNING: EXPLOSION HAZARD

Substitution of components may impair suitability for Class 1 Div.2, Class 1 Zone 2, and Zone 2 [ATEX] non-incendive approval.

AVERTISSEMENT: RISQUE D'EXPLOSION

Substituer des composants peut compromettre la conformité de la Classe 1 Div.2, Classe 1 Zone 2, et de la Zone 2 [ATEX] pour l'approbation de produits non inflammables.



WARNING

Wiring to and from this enclosure must utilise wiring methods suitable for Class 1 Div.2, Class 1 Zone 2, and Zone 2 [ATEX] Hazardous Locations as appropriate to the installation.

AVERTISSEMENT

Le câblage de ce boîtier doit respecter les méthodes d'installation appropriées en ce qui concerne les zones dangereuses de la Classe 1 Div. 2, de la Classe 1 Zone 2 et de la Zone 2 [ATEX].



WARNING

Do not disconnect terminals or remove modules when energised.
(Class 1 Div.2, Class 1 Zone 2, and Zone 2 [ATEX])

AVERTISSEMENT

Ne pas déconnecter les terminaux ou supprimer les modules lorsque l'appareil est sous tension.
(Classe 1 Div.2, Classe 1 Zone 2, et Zone 2 [ATEX])

This wall mounted enclosure is certified for use in hazardous areas / locations (Class 1 Div.2, Class 1 Zone 2, and Zone 2 [ATEX]). This enclosure can only be used as a remote unit due to its classification, and no User Interface option is available.

This unit is IP 66 Type 4 & 4x and can be installed indoors or outdoors in a Pollution Degree 4 environment, and can be exposed to rain, snow and direct UV rays (sunlight).

TECHNICAL SPECIFICATIONS

21.3 Floor Standing Enclosures



WARNING

Protect from direct exposure to precipitation and sunlight.

AVERTISSEMENT

Protéger des expositions directes au soleil et de la pluie.

Ventilated enclosures must only be installed in a place that provides a Pollution Degree 2 environment, e.g. places that afford protection from rain, snow and direct UV rays (sunlight). Such an environment would include laboratories, offices and Control rooms.

Non-ventilated (sealed) enclosures can be installed indoors or outdoors in a Pollution Degree 3 environment, but one that affords total protection from rain, snow and direct UV rays (sunlight).

21.3.1 Floor Standing Enclosures with and without Ventilation

Part Number	TPPR-V-1250 TPPR-V-1260	TPPR-V-1252 TPPR-V-1262	TPPR-V-1254 TPPR-V-1264
Material	No Ventilation	Natural Ventilation	Forced Ventilation
Dimensions (H x W x D)	2000 x 800 x 600 mm	2000 x 800 x 600 mm	2000 x 800 x 600 mm
Weight	201 Kg	201 Kg	201 Kg
Electrical Rating	100 – 240 VAC; 50/60 Hz; 2028 W max or 24 VDC nominal (18 – 32 VDC); 2450 W max. W max is dependent on module and PSU configuration.		
Class	Equipment Class 1 (grounded)		
Altitude	2000 m ASL max. in permanently-connected continuous operation.		
Pollution Degree	2 (ventilated); 3 (non-ventilated)		
Ambient Temperature	-25 °C to +55 °C (Remote version with PSU's)		
Humidity	10 to 90% RH non-condensing (ventilated), 0 to 100% RH condensing (non-ventilated)		
Ingress Protection	Type 1 / IP2X (ventilated); Type 4, 12 / IP56 (non-ventilated).		

TECHNICAL SPECIFICATIONS

21.4 Power Supplies and Fuses

21.4.1 Power Supply Units

Power Supply	120 W (5 A)	240 W (10 A)	480 W (20 A)
Input Voltage Range	85 – 276 VAC; 88 – 187 VDC		
Input Frequency Range	50 – 60 Hz ± 6%		
Input AC current	1.10 A at 120 VAC 0.62 A at 230 VAC	2.22 A at 120 VAC 1.22 A at 230 VAC	4.56 A at 120 VAC 2.48 A at 230 VAC
Output Voltage	DC 24 V (Adjustable 24 – 28 VDC)		
DC OK Relay contact ratings (max.)	60 VDC @ 0.3 A / 30 VDC @ 1 A / 30 VAC @ 0.5 A resistive load		
Protection	Short Circuit, Overload protected. Over-Volt, Over-Temp		
Dimension	40 x 124 x 117 mm (W x H x D)	60 x 124 x 117 mm (W x H x D)	82 x 124 x 117 mm (W x H x D)
Operating Temperature	–25 °C to +60 °C (–13 °F to +140 °F)		
De-rating (60°C to 70°C)	3 W / °C	6 W / °C	12 W / °C
Storage Conditions	–40° to +85° C (–40° F to +185° F), 5 to 95 %RH (non-condensing)		
Operating Humidity	5 to 95 %RH (non-condensing)		

21.4.2 DIN Rail (Module Supply and Communication)

Description	Standard DIN Rail – used for mounting Power Supplies, Backplanes and Modules
Total Width	430 mm / 487 mm (Options)
Type	TS–35/15

21.4.3 Ring Coupling Module (RCM)

Description	Module for signal connection of DIN Rail mounted I/O modules to Ring Network
Electrical Connection	2 x Ring Network TX / RX Driver Pairs (Each two-wire plus Drain)
Supply Voltage	18 – 32 VDC
Power Consumption	Maximum 1 W
Power Dissipation	Maximum 1 W
Ring Network Cable	Good quality RS485, shielded twisted pair plus Drain and Overall Screen
Operating Temperature	–40°C to +70°C
Storage Temperature	–40°C to +70°C
Environmental Protection Class	Equipment Class III, Installation Cat 2, Pollution Degree 2

TECHNICAL SPECIFICATIONS

21.4.4 Backplane

Description	5, 7, 9 and 10 I/O slot (excluding first slot reserved for RCM) backplane PCB for providing power and Ring Network connections to the RCM and I/O modules
Electrical Connection	Two-wire (+V and -V) connector at Power Supply Input for 5, 7, 9 I/O Slot Backplane 2 x two-wire (+V and -V) at Power Supply Input for 10 I/O Slot Backplane 10-pin backplane connector for connection to RCM and I/O Modules
Supply Voltage	18–32 VDC
Backplane current Rating	Maximum 20 A
Backplane connector	Maximum 32 V, 4.04 A
Environmental Protection Class	Equipment Class III, Installation Cat 2, Pollution Degree 2
Operating Temperature	-40 °C to +70 °C
Storage Temperature	-40 °C to +70 °C

21.4.5 Power Supply Redundancy Module (RDN Module)

Description	Suitable for redundant operation of DC 24 V
Input Voltage Range	8.4 – 36.4 VDC
Number of Inputs	2
Input Current (max.)	20 A per input
Output Reverse Voltage (max.)	40 VDC
Output Current (max.)	40 A
Output Voltage Drop	72 mV typical for input: 2x10 A
Dimension	140 mV typical for input: 2x20 A
Operating Temperature	36 mm x 124 mm x 127 mm (W x H x D)
Storage Conditions	-40 °C to +70 °C (-40 °F to 158 °F)
Operating Humidity	5 to 95 %RH (non-condensing)

TECHNICAL SPECIFICATIONS

21.4.6 Uninterruptible Power Supply Module (UPS)

Description	23.3 VDC – 30 VDC
Input Current	70 mA typical internal current consumption Current consumption for battery charging in constant current mode at 24V input 1.7 A typical at battery selector position <10Ah 3.4 A typical at battery selector position >10Ah
Output Voltage	DC 24 V (nominal) in Normal Operation Adjustable in Battery Operation
Output Current	Max. 25 A in Normal Operations min. 20 A in Battery Operation
Allowed Batteries	2 x 12 V 3.9 Ah – 130 Ah VRLA (sealed lead acid) type
Dimension	46 mm x 124 mm x 127 mm (W x H x D)
Operating Temperature	–40 °C to +70 °C
Operating Humidity	5 to 95 %RH (non-condensing)
De-rating 60 °C to 70 °C	0.5 A / °C
Storage Conditions	–40 °C to +85 °C, 5 to 95 %RH (non-condensing)

21.4.7 Backup Batteries

Description	2 x 12 V (24 V nominal) sealed lead acid batteries
Battery type	FIAMM 12 V 12 Ah FG21202 or 12 V 27 Ah FG22703
Dimensions	395 mm x 300 mm x 215 mm (W x H x D)
Weight	15.7 kg (12 Ah) / 25 kg (27 Ah)
Operating Temperature	–20 °C to +45 °C
Operating Humidity	10 to 90 %RH non condensing
Storage conditions	–20 °C to +40 °C, 10 to 90 %RH
Storage Lifetime without re-charge	18 months at <5 °C, 6 months at 25 °C, 3 months at 30 °C, 2 months at 40 °C
Ingress Protection	IP20, NEMA Code 1
Input Voltage (charging)	25 VDC to 28 VDC (UPS Supervised)
Output Voltage (when supplying)	20 VDC to 28 VDC (dependent on charge level)
Maximum Input Current	3 A
Maximum Output Current	20 A
Environmental Protection Class	Equipment Class III, Installation Cat 2, Pollution Degree 2
Fuse type (inline)	Bussman 20 A Fast Acting Type ABC–20–R – 1¼' x ¼' Ceramic Tube
Current Limit Protection	Double pole circuit breaker / Isolator, 20 A
Maximum Altitude	2000 m (6562 feet)

TECHNICAL SPECIFICATIONS

21.4.8 Cabinet DC Fuses

All cabinet DC fuses must be UL 248 Special Purpose Fuses complying with ISO 8820–3:2002(E), and should have:

Interrupting Rating:	1000 A at 32 VDC minimum			
Insulation Body	UL 94–V0 Heat–Resistant Thermoplastic			
Insulation Cover	Clear Thermoplastic			
Fusible element	Visible Melting			
Description	Type (Littel Fuse)	I²t	Amps	Colour
Backplanes Fuse 2	TAC ATO® or ATO Ag (Silver)™ or ATOF® Blade	TAC ATO® 600 A ² s	20	Yellow
		ATO Ag (Silver)™ 520 A ² s		
		ATOF® 520 A ² s		
Backplanes Fuse 3	TAC ATO® or ATO Ag (Silver)™ or ATOF® Blade	TAC ATO® 600 A ² s	20	Yellow
		ATO Ag (Silver)™ 520 A ² s		
		ATOF® 520 A ² s		
Backplanes Fuse 4	TAC ATO® or ATO Ag (Silver)™ or ATOF® Blade	TAC ATO® 600 A ² s	20	Yellow
		ATO Ag (Silver)™ 520 A ² s		
		ATOF® 520 A ² s		
Backplanes Fuse 5	TAC ATO® or ATO Ag (Silver)™ or ATOF® Blade	TAC ATO® 600 A ² s	20	Yellow
		ATO Ag (Silver)™ 520 A ² s		
		ATOF® 520 A ² s		
Backplanes Fuse 6	TAC ATO® or ATO Ag (Silver)™ or ATOF® Blade	TAC ATO® 600 A ² s	20	Yellow
		ATO Ag (Silver)™ 520 A ² s		
		ATOF® 520 A ² s		
CMA, Light & Fan Fuse 1	TAC ATO® or ATO Ag (Silver)™ or ATOF® Blade	TAC ATO® 35.0 A ² s	5	Lt. Brown
		ATO Ag (Silver)™ 26 A ² s		
		ATOF® 26 A ² s		
CMA, Light & Fan Fuse 7	TAC ATO® or ATO Ag (Silver)™ or ATOF® Blade	TAC ATO® 35.0 A ² s	5	Lt. Brown
		ATO Ag (Silver)™ 26 A ² s		
		ATOF® 26 A ² s		
CMA, Light & Fan Fuse 8	TAC ATO® or ATO Ag (Silver)™ or ATOF® Blade	TAC ATO® 35.0 A ² s	5	Lt. Brown
		ATO Ag (Silver)™ 26 A ² s		
		ATOF® 26 A ² s		
UPS Fuse 0 (Dual PSU, single UPS setup)	TAC ATO® or ATO Ag (Silver)™ or ATOF® Blade	TAC ATO® 600 A ² s	25	White
		ATO Ag (Silver)™ 1080 A ² s		
		ATOF® 1080 A ² s		

TECHNICAL SPECIFICATIONS

21.5 Control Module and User Interface

21.5.1 Controller & Remote Unit DC Input Supply

Input Voltage	DC 24 V (nominal)
DC Input Voltage Range	18 – 32 VDC (Supplied from Self Enclosed Low Voltage source only)

21.5.2 Control Module and User Interface

Description	Front panel User Interface Assembly
Supply Voltage	18 – 32 VDC (Supplied from Self Enclosed Low Voltage source only)
Power Consumption	Maximum 13 W
Ring Communication Physical layer	Isolated RS485
Ring Network Cable	Two x 1 mm ² twisted pair cable
Relay Outputs	Two x System State Relays
Relay Contacts	Min. 12 VDC, 10 mA
	Max. 5 A at 250 VAC / 30 VDC (non-inductive)
Interfaces	5.7 inch, 320 x 240 pixels (QVGA), Touch Screen LCD
	LED and Button Panel with LEDs for Power, Alarm and Fault indication. Buttons for Accept and Reset functions
	Buzzer for audio indication of Alarm/Faults (Sound Level: 85 dB at 100 mm)
	USB 2.0 Device Interface with standard Type B USB connector to interface with PC/Laptop for configuration. Supports FAT32 USB memory device up to 32 Gb. Industrial grade devices recommended.
	Standard FAT32 SD Card Interface 4 Gb to 32 Gb Supports 24 mm x 32 mm x 2.1 mm cards. Industrial grade cards recommended.
	10/100 Mbps Ethernet Interface with standard RJ-45 connector
	Two x RS-485 Modbus connections supporting maximum 115.2 kbps
Panel Dimension	483 mm x 222 mm
Retention of Real Time Clock	72 hours unpowered

TECHNICAL SPECIFICATIONS

21.6 I/O Modules

21.6.1 Common Specifications

Dimensions	35.0 mm x 99.5 mm x 114.5 mm (W x H x D)
Installation	May be fitted to 5, 7, 9 or 10-way Communication / Power Rail
Maximum wire size	2.5 mm ²
IP Rating	IP20
EMC	EN 50270
Power supply	18 – 32 VDC
Casing material	Polyamide PA 6.6 V0 (UL94)
Operating Temperature Range	–40 °C to +70 °C
Storage Conditions	–40 °C to +70 °C
Operating Humidity Range	10 to 90 %RH (non–condensing)
Weight	210 g
Environmental Protection Class	Equipment Class III, Installation Cat 2, Pollution Degree 2

21.6.2 Analogue Input Module mA

Description	4-channel 4 – 20 mA Analogue Input Module with two or three-wire interface to detector
Sensor Configuration	4 x two-wire or three-wire sink only (current sourced from detector)
Signal Measurement Range	0 – 25 mA
Supply Voltage	18 – 32 VDC (Supplied from Self Enclosed Low Voltage source only)
Field Device Supply Voltage	Supply Voltage (Vs) – 0.7 V
Single Channel Field Device Supply current	Maximum 1 A
Total Field Device supply current	Total Maximum current : 2 A at 70 °C ambient Total Maximum current : 4 A at 60 °C ambient
Power Consumption	0.8 W (Excluding sensor supply)
Power Dissipation	Maximum 3.7 W, at 4 A total field device load Maximum 2.1 W, at 2 A total field device load
Sense Resistance	101 Ω
Connector Coding	Analogue Input Module connectors (TB1–TB4) have coding keys to avoid incorrect wiring

TECHNICAL SPECIFICATIONS

21.6.3 Analogue Input Module mV Bridge

Description	4-channel Analogue Input Module for Catalytic Bridge sensors
Electrical Connection	4 x three-wire mV Bridge
Supply Voltage	18 – 32 VDC
Sensor Drive method	Constant current
Programmable Current Range	180 – 360 mA programmable
Maximum Loop Resistance	Total Maximum loop resistance: 40 Ω at 200 mA (including Sensor) Total Maximum loop resistance: 27 Ω at 360 mA (including Sensor)
Input Range	± 15 mV to ± 600 mV
Power Consumption	Maximum 1.2 W (Excluding Sensors)
Power Dissipation	Maximum 3.5 W
Connector Coding	Analogue Input Module connectors (TB1–TB4) have coding keys to avoid incorrect wiring

21.6.4 Digital Input Module

Description	4-channel Digital Input Module for switched input devices
Electrical Connection	4 x two-wire voltage-free Inputs
Supply Voltage	18 – 32 VDC
Power Consumption	2.8 W maximum (no inputs connected)
Power Dissipation	2.8 W maximum
Field Terminals (TB1–TB4) Ratings	Maximum current of 14 mA through switched input device at 18 – 32 VDC
EOL (End Of Line) Resistance	10 k Ω , 0.25 W, $\pm 1\%$
INL (In–Line) Resistance	2.7 k Ω , 0.25 W, $\pm 1\%$
Switch Input Device supply Voltage (Vs)	Minimum 15 V Maximum 32 V
Switch Input Device supply Current (Is)	Minimum 5 mA for Supervised OC/SC Switch ON condition Maximum 14 mA for Unsupervised Switch ON condition
Connector Coding	Digital Input Module connectors (TB1–TB4) have coding keys to avoid incorrect wiring

TECHNICAL SPECIFICATIONS

21.6.5 Relay Output Module

Description	4-channel Relay Output Module incorporating 4 single pole change over (SPCO) relays and 24 VDC Auxiliary Power Output
Electrical Connection	4 x SPCO Relay Terminals (TB1 to TB4) 4 x two-wire Auxiliary Output Terminals (TB5 to TB8)
Supply Voltage (Vs)	18 – 32 VDC
Auxiliary Supply Voltage	Supply Voltage (Vs) – 0.7 V
Auxiliary Supply Current	Maximum 1.5 A
Power Consumption	Maximum 1.5 W (excluding auxiliary power consumption)
Power Dissipation	Maximum 2.3 W
Relay Contacts (TB1–TB4)	Maximum 5 A through one relay contact at 250 VAC / 30 VDC (non-inductive) Maximum 8 A total through all four relay contacts at 250 VAC / 30 VDC (non-inductive) Minimum 12 VDC, 10 mA
Connector Coding	Relay output connectors (TB1–TB4) and auxiliary output connectors (TB5–TB8) have coding keys to avoid incorrect wiring The relay output connectors (TB1–TB4) are coloured black to identify them for AC supply wiring

CERTIFICATION

22 Certification

22.1 EU Declaration of Conformity

A full EU declaration of conformity is available on the CD accompanying the product. This document lists the European Standards with which the TPRR complies.



WARNING

Only the combustible gas portion has been assessed for performance in accordance with CSA 22.2 No. 152 & FM 6310 / 20.
 CSA performance is only valid when connected to Honeywell Model 705 Catalytic Gas Detectors or suitably approved 4 – 20 mA Gas Detectors.

AVERTISSEMENT

Seule la partie de gaz combustible a été évaluée en ce qui concerne la performance en conformité avec la norme CSA 22.2 No. 152 & FM 6310/20
 La performance en conformité avec la CSA est valide uniquement lorsque l'appareil est connecté aux détecteurs de gaz catalytiques Honeywell modèle 705 ou à des détecteurs de gaz 4 - 20 mA dûment approuvés.

22.2 Applicable National and International Standards

The TPRR systems described in this manual are declared to conform to the following National and International Standards when installed and operated in accordance with the Manufacturer's specifications and stipulations:

Ordinary Location Standards	Zone 2 Div. 2 Hazardous Location Standards	European Performance Approvals	Functional Safety
CAN/USA – C22.2 No. 61010-1 CSA 22.2 No. 152 UL Std – No. 61010-1 EN/IEC 61010-1 FM 6310 & 6320	ANSI/ISA –12.12.01 CAN/CSA C22.2 No. 60079-0 CAN/CSA C22.2 No. 60079-15 CSA C22.2 No. 0-M CSA C22.2 No. 213-M EN/IEC 60079-0 EN/IEC 60079-15 UL 60079-0 UL 60079-15 FM 6310 & 6320	EN 60079-29-1 EN 50104 EN 45544 EN 50271	IEC 61508

Table 47. Applicable National and International Standards

CERTIFICATION

22.3 National and International Certificates for Zone 2 Div. 2

The TPPR Zone 2 Div. 2 Systems and System Components hold the following National and International Certificates and Certification Codes:





Description	Certificates
Remote Wall Mount Zone 2/Div. 2 Enclosure and ROM (ATEX/IECEX) 	II 3G Ex nA nC IIC T4 Gc (ROM) Tamb -40 °C to +70 °C (Enclosure) Tamb -40 °C to +xx °C* * See Rating Plate
Remote Wall Mount Zone 2/Div. 2 Enclosure and ROM (CSA US/CAN) 	Class I, Div. 2, ABCD T4 Class I, Zone 2, AEx nA nC IIC T4 Class I, Zone 2, Ex nA nC IIC T4 (ROM) Tamb -40 °C to +70 °C (Enclosure) Tamb -40 °C to +xx °C* * See Rating Plate
AIM mA, AIM mV, DIM, RCM and Backplanes (ATEX/IECEX) 	II 3G Ex nA IIC T4 Gc Tamb -40 °C to +70 °C
AIM mA, AIM mV, DIM, RCM and Backplanes (CSA US/CAN) 	Class I, Div. 2, ABCD T4 Class I, Zone 2, AEx nA IIC T4 Class I, Zone 2, Ex nA IIC T4 Tamb -40 °C to +70 °C
Remote Wall Mounted Zone 2/Div. 2 Enclosure	SIRA 15ATEX4034X IECEX SIR15.0021X CSA 70030437
AIM mA	SIRA 15ATEX4028U IECEX SIR15.0015U CSA 70004992
AIM mV	SIRA 15ATEX4029U IECEX SIR15.0016U CSA 70025468
DIM	SIRA 15ATEX4030U IECEX SIR15.0017U CSA 70025478
ROM	SIRA 15ATEX4031U IECEX SIR15.0018U CSA 70025950
RCM	SIRA 15ATEX4032U IECEX SIR15.0019U CSA 70025951
Backplanes	SIRA 15ATEX4033U IECEX SIR15.0020U CSA 70025953

Table 48. National and International Certificates

22.4 European Performance Approval (DEKRA Exam) for Systems

TPPR has been approved by DEKRA Exam for use in the measurement of oxygen as well as combustible and toxic gases. The certification marking that is applied to the product is shown below:

 Ex II (1) GD

BVS 16 ATEX G 002 X for EN 60079-29-1, EN 50104 and EN 50271

PFG 16 G 002 X for EN 50104, EN 45544-1/2/3 and EN50271

CERTIFICATION

22.4.1 Approved Components

The following system components have been tested and approved by DEKRA Exam

CCB & CCB-R	TPPR-V-2120
COB	TPPR-P-2110
Local HMI	TPPR-V-0852
CM Motherboard	TPPR-P-2100
Bus Interface Board	TPPR-V-2130
Backplane 10 Way	TPPR-P-0540
Backplane 9 Way	TPPR-P-0530
Backplane 7 Way	TPPR-P-0525
Backplane 5 Way	TPPR-P-0520
19" Rack (with HMI)	TPPR-V-0602
19" Rack (remote)	TPPR-V-0612
Wall Mount Remote (Small)	TPPR-V-1215
AIM mA	TPPR-V-1000
AIM mV	TPPR-V-1010
DIM	TPPR-V-1030
ROM	TPPR-V-1040
RCM	TPPR-V-1050

Note: The PC configuration software has not been assessed by DEKRA Exam. If this software is used to configure the TPPR system the configuration must be verified before use, for example by confirming the printed system configuration and channel configuration reports.

Note: The power supply units have not been assessed by DEKRA Exam. Any suitable power supply may be used.

CERTIFICATION

22.4.2 Special Conditions for Use When Used for Explosion Protection

Refer to certificate **BVS16 ATEX G 002 X**.

When using 4-20 mA transmitters, pay particular attention to the following:

- - The specifications of the 4-20 mA interface
- - Behaviour with currents less than 4 mA
- - Behaviour with currents in excess of 20 mA

For each channel, the alarm with the highest significance for safety shall be configured as Latching.

Time delayed relays should not be used for safety related purposes. If their use is unavoidable, the delay time shall be set to the minimum possible for the required operation. The maximum possible rate of increase of gas concentration shall be taken into account when determining the delay time.

A latching Fault Relay shall be associated with each channel using Sensepoint ppm catalytic sensors to achieve a reliable indication in the event of the sensor being flooded with high gas concentrations. A Master fault relay may be configured where appropriate, or one or more designated relays configured in the Cause and effect matrix.

All controls, including digital inputs, inputs from webserver and inputs from Modbus shall be protected against unauthorised or inadvertent interference or operation.

When monitoring flammable gases or vapours, the following configuration limits shall be observed:

- - The parameter **Under Range Fault Limit** shall not be set below -10 %FSD.
- - The parameter **Zero Suppression Positive** shall not be set above +5 %FSD.

The parameter **Over Range Warning Latch** shall be set to latching when used with remote sensors or transmitters which may give indications within their measuring range at gas concentrations above the configured measuring range.

When monitoring oxygen, the following configuration limits shall be observed:

- The parameter **Under Range Fault Limit** or the parameter **Zero Suppression Negative** shall not be set below -2 %FSD.
- The parameter **Zero Suppression Positive** shall not be set above +2 %FSD.

22.4.3 Special Conditions for Use When Used for Measurement of Toxic Gases or Oxygen

Refer to Certificate **PFG 16 G 002 X**.

When used as EN 45544-2 apparatus, Touchpoint Pro is suitable for use with transmitters where the output at the limit value is between 4.96 mA and 12 mA.

When using 4-20 mA transmitters, pay particular attention to the following:

- The specifications of the 4-20 mA interface
- Behaviour with currents less than 4 mA
- Behaviour with currents in excess of 20 mA

For each channel, the alarm with the highest significance for safety shall be configured as Latching.

Time delayed relays should not be used for safety related purposes. If their use is unavoidable, the delay time shall be set to the minimum possible for the required operation. The maximum possible rate of increase of gas concentration shall be taken into account when determining the delay time.

All controls, including digital inputs, inputs from webserver and inputs from Modbus shall be protected against unauthorised or inadvertent interference or operation.

When monitoring oxygen, the following configuration limits shall be observed:

- The parameter **Under Range Fault Limit** or the parameter **Zero Suppression Negative** shall not be set below -2 %FSD.
- The parameter **Zero Suppression Positive** shall not be set above +2 %FSD.

When monitoring toxic gases, the following configuration limits shall be observed:

- The parameter **Under Range Fault Limit** shall not be set below -10 %FSD.
- The parameter **Zero Suppression Positive** shall not be set above the lower limit of measurement when used according to EN 45544-2.
- The parameter **Zero Suppression Positive** should not be set above +5 %FSD when used according to EN 45544-3.

CERTIFICATION

22.4.4 Configuration of Relay Outputs for safety-related switching operations

The System State relays and any other relays configured for safety purposes should be wired to a continuously monitored system for safe operation. This is to ensure that all system faults are detected promptly and appropriate action taken

Each ROM output must be configured as Normally Energized, Alarm Update Enable not selected, and Latch Function selected, as shown in the following example:

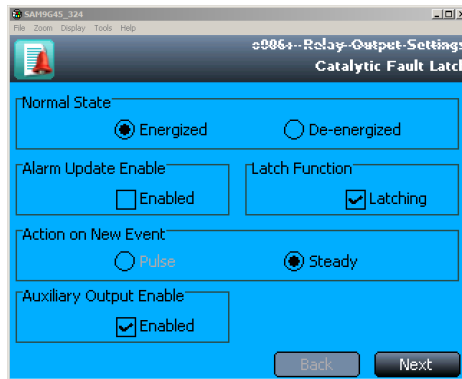

Figure 105. Fault Latch Output Configuration

22.4.5 Compliance with EN 45544-2 (Toxic Gases)

The lower limit of measurement of Touchpoint Pro is 0.08 % of the transmitter’s full scale deflection. Therefore the zero suppression positive parameter must not be set higher than 0.08 % of the transmitter’s full scale deflection to avoid suppression of valid measured values.

To maintain compliance with EN 45544 the calibration interval must not exceed 6 months.

Touchpoint Pro is suitable for use with transmitters where the output at the limit value is between 4.96mA as 12.0 mA. Please refer to EN4544-1 Annex A for further information.

22.4.6 Compliance with EN 50104 (Oxygen)

TPPR is approved for measurement of oxygen deficiency, enrichment and inertisation.

22.4.7 Important Notes on Certification

TPPR is a fully customizable installation, so all of the possible variations cannot be certified in one guide. Instead every system will have its personalized parameters inscribed on rating labels attached to each major component (i.e. the Controller, Remote and Battery Enclosures).

For Certification and Information purposes, a tabular overview of the individual components is given in the *Specifications* chapter.

Note 1: The TPPR system contains a number of commercial-off-the-shelf (COTS) items that have been independently certified by their manufacturers whose certified parameters have been incorporated into the Specification tables.

Note 2: OEMs are responsible for ensuring that their systems are certified in accordance with these tables and any 3rd-party requirements.

Note 3: Power Supply Fluctuations shall not exceed DC 18 – 32 V SELV Supply or ±10 % of nominal.

Note 4: All equipment in this manual is rated to a maximum altitude of +2000 m (6562 ft.) AGL.

Note 5: Care must be taken that the equipment is not subjected to vibration that exceeds the levels stated in EN 60079-29-1, EN 45544 and EN 50104.



WARNING

Ambient temperature: Dependent on components fitted; check individual rating plates.

AVERTISSEMENT

Température ambiante : elle dépend des composants assemblés; vérifier individuellement les plages de température.

ORDERING

23 Ordering Information

23.1 TPPR System ID Configuration

Your TPPR has a unique System ID that incorporates a Globally Unique Identifier (GUID). A typical example might be **TPPR-HW-MF-NXHXXL-ZII8421526123**, where the first 14 characters show the system's configuration and the last 13 characters are the GUID (see box-out below).

The System ID and GUID are produced in digital, human and barcode reader formats for ease of tracking and quality control. They can be found on both the TPPR rating plate and in the UI software.

The following table shows how your TPPR System ID is constructed and this GUID can be used to provide valuable information to Technical Support if you need technical help or warranty service.

System ID	Product Name	Unit Type	Variant*	Ventilation	Plinth	Logo	BIB	CCB-R	UI
See Example below.	TPPR	HW = Wall Mount	S = Small M = Medium L = Large + F = Front Access R = Rear Access	X = None	X = None	X = None	X = None	X = None	L = Local (With UI)
		N = Natural							
		HF = Floor Standing		F = Forced	P = 100mm	H = Honeywell	M = Modbus	R = Redundancy	R = Remote (Without UI)
Example:	TPPR-	HW-	MF-	N	X	H	X	X	L

Table 49. TPPR Standard System ID Configuration Chart

FS = Front Access Floor Cabinet with 5 Backplanes
 RS = Rear Access Floor Cabinet with 5 Backplanes
 TS = Small Stainless Steel Wall Cabinet
 Z = Zone 2 Div. 2 Stainless Steel Wall Cabinet

S = Supplier Code i.e. Z for HA Poole UK
 II = Bill of Materials Issue Number
 PPP = Part Code i.e. 842 for a standard WM Enclosure
 YY = Year of Manufacture
 WW = Week of Manufacture
 NNN = Sequential Serial Number

ORDERING

23.2 TPRR Components Part Numbers

The following table lists some common TPRR components that are held by your local Honeywell Service Centre.

Item	Description	Part Number
01	SD Card, 4 Gb, FAT32	TPPR-V-0842
02	Analogue Input Module 4-20 mA	TPPR-V-1000
03	Analogue Input Module mV-Bridge	TPPR-V-1010
04	DC-UPS 40 A Module	TPPR-V-0501
05	Digital Input Module	TPPR-V-1030
06	Relay Output Module	TPPR-V-1040
07	Ring Coupling Module	TPPR-V-1050
08	Power Supply Redundancy Module 40 A	TPPR-V-0500
09	PSU 10 A, 240 W, 24 VDC	TPPR-V-0503
10	PSU 20 A, 480 W, 24 VDC	TPPR-V-0504
11	PSU 5 A, 120 W, 24 VDC	TPPR-V-0502
12	Battery Sealed Lead-Acid 12 Ah 12 V (pair)	TPPR-V-0406
13	Battery Sealed Lead-Acid 27 Ah 12 V (pair)	TPPR-V-0405
14	Modbus® Interface Board	TPPR-V-2130
15	Redundant Control Centre Board	TPPR-V-2120
16	Battery Fuse 20 A (Cartridge)	Local Purchase
17	Backplanes Fuse 20 A (White Bladed)	Local Purchase
18	CMA, Light & Fan Fuse 5 A (Brown Bladed)	Local Purchase
19	UPS Fuse 25 A (Yellow Bladed)	Local Purchase

Table 50. Spare Parts List

Please contact your local Honeywell Service Centre (see back page) if you want to order these parts as spares.

Some items are not listed as they are only available to Honeywell Service Centres, OEMs and Partners.

Unlisted expendable items (i.e. air filters) will be replaced as part of routine Field Service if required.



WARNING

The equipment specified in this manual is only to be installed by the Manufacturer's trained personnel, or by competent persons trained in accordance with the Manufacturer's installation instructions.

SAFE DISPOSAL

24 Disposal of Redundant / Unserviceable Parts

TPPR components must be disposed of in accordance with local and international laws. They shall not be disposed of by incineration or as domestic waste.



CAUTION – HEALTH AND ENVIRONMENTAL HAZARDS

PCB and Backplane e-waste is hazardous due to the presence of toxic substances such as Cadmium, Chromium, Lead, and Mercury, and flame retardants such as polybrominated biphenyls and diphenylethers.

Always dispose of e-waste in accordance with the WEEE Directive; do not dispose of it in domestic waste.

24.1 Restriction of Hazardous Substances (RoHS) Directive

TPPR is compliant with the requirements of the RoHS Directive.

24.2 Waste Electrical and Electronic Equipment (WEEE) Directive



This symbol indicates that the product and/or parts of the product may not be treated as household or municipal waste.

Waste electrical products (end of life) should be recovered/recycled where suitable specialist WEEE disposal facilities exist. For more information about recycling of this product, contact your local authority, your local agent or distributor, or the manufacturer whose details are on the back page.

24.3 TPPR System Construction

The TPPR system contains the following materials:

24.3.1 TPPR Safe Area Enclosures:

- Powder coated mild steel
- Zintec
- Polyamide PA 6.6 V0 (UL94)
- e-Waste (Backplane, PCB, Copper cables and terminals)

24.3.2 TPPR Battery Enclosure

The TPPR Backup Battery enclosures may contain 12 VDC Sealed Rechargeable Lead-Acid Batteries. These batteries contain toxic and corrosive substances that may cause injury or damage if the batteries become damaged, or if they are mishandled, incinerated or disposed of incorrectly.



CAUTION – BATTERY HANDLING AND DISPOSAL

Batteries should be disposed of separately from household waste and in accordance with local laws and regulations. Unwanted batteries shall be taken to a collection point designated by local authorities.

Always dispose of batteries in accordance with the WEEE Directive; do not dispose of them in domestic waste.

24.3.3 TPPR 19 Inch Rack

- Powder coated mild steel
- Polyamide PA 6.6 V0 (UL94)
- e-Waste (Backplane, PCB, Copper cables and terminals)

24.3.4 TPPR I/O Modules

- Casing – Polyamide PA 6.6 V0 (UL94), grey
- Contents – printed circuit boards (PCB)

SAFE DISPOSAL

24.3.5 TPPR Power Supply Units

- Casing – Back case: Aluminium; Top case (with mesh): Steel with Nickel plating
- Contents – printed circuit boards (PCB)

24.3.6 TPPR Ring Coupling Module

- Casing – Polyamide PA 6.6 V0 (UL94), green
- Contents – printed circuit boards (PCB)

24.3.7 TPPR Backplanes

- Backplane Assemblies (i.e. PCB)

24.3.8 TPPR Packaging

TPPR outer packaging will be cardboard for wall-mounted units and ISPM15 certified 19 mm solid (not machined) woods for floor standing units. Facilities for recycling are widely available.

TPPR wall-mounted enclosure inner packaging is made from Stratocell® foam. The foam can be recycled and reused as Stratocell® where such recycling facilities exist.

TPPR floor standing units may be shipped on ISPM15 certified wooden pallets that may be reused, recycled or returned.

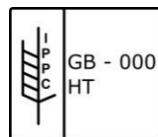

Figure 106. ISPM15 Pallet Mark Example

ILLUSTRATIONS

25 Table of Icons

Meaning	T/screen Icon	PC Config Icon	Meaning	T/screen Icon	PC Config Icon
			Tool Box		N/A
About	N/A		Filter		N/A
About Active User	N/A		Firmware Update		N/A
Active Events Screen (no active events)		N/A	Global Settings		N/A
Active Events Screen (with active events)		N/A	Go to Inputs		N/A
Add User			Go to Outputs		N/A
Back		N/A	Help		
CCB Configuration		N/A	Home		
CCB Management			Licence Cancel	N/A	
CCB Replacement		N/A	Licence Install	N/A	
Configuration Backup		N/A	Licence Manage	N/A	
Configuration Restore		N/A	Menu (T/s: select options in Input channel detail screen) (PC: configure options in System Settings)		
Delete Configuration		N/A	Modbus Settings		N/A
Diagnostics			Panel Configuration		N/A
Event History		N/A			

ILLUSTRATIONS

Meaning	T/screen Icon	PC Config Icon	Meaning	T/screen Icon	PC Config Icon
Password Change	N/A		User Management		
Regional settings		N/A	Zoom in (X axis)		N/A
Remove User	N/A		Zoom in (Y axis)		N/A
Reports		N/A	Zoom out (X axis)		N/A
Ring Network			Zoom out (Y axis)		N/A
Screen Locked (User Login)					
Screen Unlocked (User Logout)					
SD Card		N/A			
Select Language	N/A				
Sensor Catalogue Update		N/A			
Service Contact Settings		N/A			
System Configuration					
System Setup					
TCP/IP Settings		N/A			
Trend Graph Settings		N/A			

Figure 107. Icon Table

ILLUSTRATIONS

26 List of Illustrations

Figure 1.	Electrical Warning Label 1	8
Figure 2.	Electrical Warning Label 2	8
Figure 3.	Protective Earth (Ground) Point	8
Figure 4.	Equipment Earth (Ground) Point	8
Figure 5.	Controller Rear Cover with Example Labels	8
Figure 6.	Example of a Typical System Rating Label	9
Figure 7.	Typical TPPR Product Label	9
Figure 8.	Keep Children Away	10
Figure 9.	No Naked Flames	10
Figure 10.	Use Caution	10
Figure 11.	Electrical Hazard	10
Figure 12.	Read The Instruction Manual	10
Figure 13.	Wear Eye Protection	10
Figure 14.	Hazardous Waste (Pb = Lead)	10
Figure 15.	Recycle Only	10
Figure 16.	TPPR Building Blocks	12
Figure 17.	TPPR Controller with Remote Units and Field Devices	13
Figure 18.	TPPR Enclosures	14
Figure 19.	TPPR Controller Cover with Connection Map	14
Figure 20.	TPPR Controller	16
Figure 21.	TPPR Backplane	17
Figure 22.	TPPR Controller Typical Schematic	17
Figure 23.	Ring Circuit With All Modules Working	18
Figure 24.	Ring Circuit With a Failed Module	18
Figure 25.	TPPR Module Types	19
Figure 26.	Typical Power Supply Setup	20
Figure 27.	Choice of PSU Size (120 W / 240 W / 480 W)	20
Figure 28.	Power Redundancy Module Operation	21
Figure 29.	DC-UPS and Battery Configuration	22
Figure 30.	Battery Circuit	24
Figure 31.	TPPR Correct Enclosure Mounting Orientation	26
Figure 32.	Small Wall Mounted Enclosure	27
Figure 33.	Medium Wall Mounted Enclosure	27
Figure 34.	Large Wall Mounted Enclosure	27
Figure 35.	Hazardous Area Wall Mounted Enclosure	28
Figure 36.	Example of a Floor Mounted System with Forced Rear Ventilation and Vent Hood	29
Figure 37.	TPPR 19" Rack Dimensions	29
Figure 38.	TPPR Panel Mount Dimensions	30
Figure 39.	TPPR Bezel Mounting Kit	30
Figure 40.	TPPR Battery Enclosure Dimensions	32
Figure 41.	Ring Network Maximum Distances	35

ILLUSTRATIONS

Figure 42.	Shielding with Metal Armour, Metal Junction Box and Metal Sensor Body	36
Figure 43.	Shielding with no Armour, Metal Junction Box and Metal Sensor Body	36
Figure 44.	Shielding with Metal Armour, Plastic Junction Box and Plastic Sensor Body	37
Figure 45.	Shielding with no armour, Plastic Junction Box and Plastic Sensor Body	37
Figure 46.	27 Ah Battery Terminal Assembly	38
Figure 47.	Correct Battery Orientation	38
Figure 48.	Battery Connections	39
Figure 49.	Three Wire Device	40
Figure 50.	Two Wire Loop Powered Device	41
Figure 51.	Two Wire Device with a Barrier	41
Figure 52.	Two Wire Device with Alternative Barrier	41
Figure 53.	Two Wire Device with an Isolated Barrier	42
Figure 54.	mV Bridge Catalytic Detector	42
Figure 55.	Unsupervised Circuit	43
Figure 56.	Supervised for Open Circuit	43
Figure 57.	Supervised for Open and Short Circuit	43
Figure 58.	ROM Connections	44
Figure 59.	Controller's Terminal Layout Map	45
Figure 60.	Ring Network Connections	46
Figure 61.	Ring Network – Dual Backplane	46
Figure 62.	Representative Screen Connections	47
Figure 63.	PSU Status Circuit	48
Figure 64.	System Status Screen	49
Figure 65.	Controller Cover Panel	52
Figure 66.	Bus Interface Board (BIB) Fitting	52
Figure 67.	Modbus RTU Interface Terminals	53
Figure 68.	Six Modbus Configuration Options	54
Figure 69.	Modbus BIB Jumper Default Settings	55
Figure 70.	Panel Configuration Screen	56
Figure 71.	Calibration Screen	61
Figure 72.	Zero Calibration Screen	61
Figure 73.	Enter Span Gas Concentration	61
Figure 74.	Span Gas Calibration screen	62
Figure 75.	Calibration Screen, Span	62
Figure 76.	mA Calibration Screen	63
Figure 77.	mA Zero Calibration	63
Figure 78.	mA Span Calibration	64
Figure 79.	Programmable Signal Parameters	65
Figure 80.	Delete Configuration Screenshots	104
Figure 81.	CCB Configuration Screen	105
Figure 82.	Safe System Interaction Screen	105
Figure 83.	Select Buzzer Screen	106
Figure 84.	System Status Normal	109

ILLUSTRATIONS

Figure 85.	System Status with Example Active Events	109
Figure 86.	Touchscreen Navigation – Input and Output	110
Figure 87.	Touchscreen Navigation – Active Events	111
Figure 88.	Input Details Screen	113
Figure 89.	Outputs Screen	113
Figure 90.	Outputs Screen with filter options	113
Figure 91.	Trend Graph Screen	114
Figure 92.	Fault Latch Output Configuration	122
Figure 93.	Active Events Screen with Filter Options	125
Figure 94.	Active Events Screen Showing the Filter Option Buttons	126
Figure 95.	Inputs Screen with menu options	128
Figure 96.	Fitting a Module to the DIN Rail	139
Figure 97.	DC-UPS Signal Key	141
Figure 98.	Ring Fault Type 1	160
Figure 99.	Ring Fault Type 2	161
Figure 100.	Ring Fault Type 3	161
Figure 101.	Ring Fault Type 4	161
Figure 102.	Ring Fault Type 5	162
Figure 103.	Ring Fault Type 6	162
Figure 104.	Ring Fault Type 7	162
Figure 105.	Fault Latch Output Configuration	181
Figure 106.	ISPM15 Pallet Mark Example	185
Figure 107.	Icon Table	187

TABLES

27 List of Tables

Table 1.	TPPR Access Levels	11
Table 2.	TPPR Module Types	19
Table 3.	PSU Terminal Allocation	21
Table 4.	DC-UPS Primary Terminal Allocation	22
Table 5.	DC-UPS Secondary Terminal Allocation	22
Table 6.	DC-UPS LED Meanings	23
Table 7.	Backup Battery Details	23
Table 8.	Approximate Wall Mounted Enclosure Weights	26
Table 9.	AIM mA Connection Table	40
Table 10.	AIM mV Connection Table	42
Table 11.	IM Connection Table	43
Table 12.	ROM Connection Table (Unpowered)	44
Table 13.	RCM Connection Table	45
Table 14.	Communications Ring Cable	47
Table 15.	System State Relay Connections	48
Table 16.	PSU Input Connections	48
Table 17.	Modbus Parameter Settings	96
Table 18.	Modbus Input Channels	96
Table 19.	Modbus Output Channels	96
Table 20.	Modbus System Summary	97
Table 21.	Modbus System Summary Continued	97
Table 22.	Modbus System Summary Continued	97
Table 23.	Modbus Channel Analogue Values	97
Table 24.	Modbus Channel Analogue Values (Float)	97
Table 25.	Modbus Channel Animation Register	98
Table 26.	Modbus Channel Animation Register Continued	98
Table 27.	Query Poll Register	99
Table 28.	Query Poll Register Values	99
Table 29.	Query Poll Descriptions	99
Table 30.	Query Poll Types	99
Table 31.	Query Poll Example	100
Table 32.	Command Poll Registers	100
Table 33.	Command Poll Register Values	100
Table 34.	Command Types	100
Table 35.	Command Type Example	101
Table 36.	Modbus Exception Responses	101
Table 37.	System Alert Icons	108
Table 38.	Input Channel Menu Options	112
Table 39.	Inhibit / Force Options	114
Table 40.	System State Relay Operation	117

TABLES

Table 41.	Rising Gas Reading	121
Table 42.	Falling Gas Reading	121
Table 43.	Action on Falling Alarms	122
Table 44.	Potential Issues	146
Table 45.	Error Codes and Remedies	157
Table 46.	Example of a Ring Fault Event Log	158
Table 47.	Applicable National and International Standards	177
Table 48.	National and International Certificates	178
Table 49.	TPPR Standard System ID Configuration Chart	182
Table 50.	Spare Parts List	183

Find out more

www.honeywellanalytics.com

Contact Honeywell Analytics:**Europe, Middle East, Africa**

Life Safety Distribution GmbH

Javastrasse 2

8604 Hegnau

Switzerland

Tel: +41 (0)44 943 4300

Fax: +41 (0)44 943 4398

gasdetection@honeywell.com

Customer Service

Tel: 00800 333 222 44 (Freephone number)

Tel: +41 44 943 4380 (Alternative number)

Fax: 00800 333 222 55

Middle East Tel: +971 4 450 5800 (Fixed Gas Detection)

Middle East Tel: +971 4 450 5852 (Portable Gas Detection)

Americas

Honeywell Analytics Inc.

405 Barclay Blvd.

Lincolnshire, IL 60069

USA

Tel: +1 847 955 8200

Toll free: +1 800 538 0363

Fax: +1 847 955 8210

detectgas@honeywell.com

Asia Pacific

Honeywell Analytics Asia Pacific

7F SangAm IT Tower,

434 Worldcup Buk-ro, Mapo-gu,

Seoul 03922, Korea

Tel: +82 (0)2 6909 0300

Fax: +82 (0)2 2025 0328

India Tel: +91 124 4752700

analytics.ap@honeywell.com

Technical Services

EMEA: HAexpert@honeywell.com

US: ha.us.service@honeywell.com

AP: ha.ap.service@honeywell.com

www.honeywell.com

Please Note:

While every effort has been made to ensure accuracy in this publication, no responsibility can be accepted for errors or omissions. Data and legislation may change and you are strongly advised to obtain copies of the most recently issued regulations, standards and guidelines.

This publication is not intended to form the basis of a contract.

Honeywell

Part Number 2400M2501

Issue 6

© 2018 Honeywell Analytics



DETECTION | **S**AFETY | **P**ROTECTION

For Pricing or Further
Information Please Contact Us.



+441158390495



www.manonglobal.com



sales@manonglobal.com

**Leading UK Suppliers In
Gas Detection, Safety & Protection
Products
Brand New & Genuine OEM Parts
UK & Worldwide Deliveries Available**



Worldwide Delivery



1000+ Genuine Parts & Equipment