

USER MANUAL

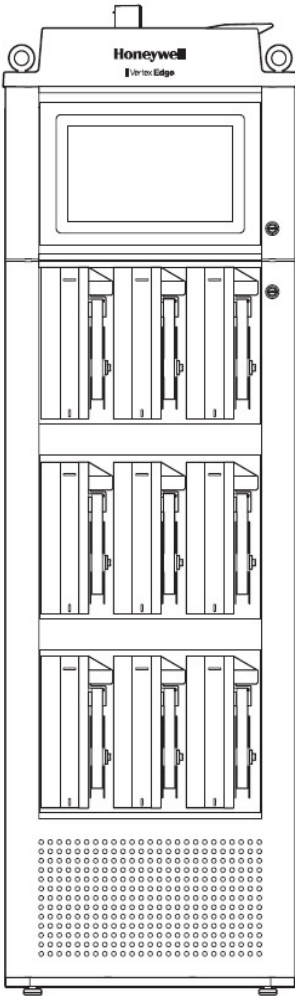

Vertex™ Edge

72-POINT CONTINUOUS MONITOR

Honeywell

TOC

Safety	6
Trademarks	6
General Safety	6
Continuous Monitor Symbols	6
EMC Considerations	7
FCC Compliance Statement	7
Industry Canada Statement	7
China RoHS	8
Cabling	8
Connectors	9
Introduction	10
System Overview	10
System Components	11
Analyzer Modules	19
Sampling System	19
Chemcassette Detection System	20
Vacuum Pumps	23
Multiple Gas Monitoring	23
Control Systems	23
Data Acquisition Computer	24
Installation	26
Installation Step 1: Surveying the Installation Site	26
Optional Installation Step 2: Floor Mounting	29
Installation Step 3: Installing Sample Lines	30
Installation Step 4: Installing the Pump Exhaust Line	33
Installation Step 5: Electrical Power	34
Installation Step 6: Data Acquisition System	43
Start-up	45
Getting Ready for the Start-up	45

Power On	47
Start Program	48
Create a Configuration Profile	49
Login and Logout	63
Create a New User	65
Install the Chemcassette	65
Adjust Supply Vacuum	69
Adjust the Flow Rate	74
Device Operations	76
Edit User Accounts	77
View Overview Status	78
View Analyzer Status	80
View Detailed Analyzer Information	81
View Detailed Point Data	83
Acknowledge Notifications	84
Create an HMI Backup Data	86
Reset Passwords to Defaults	93
Database settings	94
Alternate The Pump close to Due Date	94
Turn a Pump On And OFF	96
Turn the Monitoring Mode On and OFF	97
Open the Optic Gate	98
Release the Analyzer Lock	99
Advance the Chemcassette Tape	100
Adjust the Optic Block	101
Test Optic Block	102
View Optic Status	109
Sample Line Filter Replacement Counter	111
View and Export the Events History Listed By Time	113
Export the Events History	113
View and Export The Events History by Analyzer	116

View Help File	117
View System Version Information	117
Activate Optional Function	122
System Shutdown	123
Line Integrity Test (LIT)	125
Quantitative Performance	125
Configure Line Integrity Test	127
Characterize Line integrity Test	128
Performing Line Integrity Test	129
Maintenance	134
Maintenance Schedule	134
Replace an Analyzer	135
Install an Analyzer	139
Return to Service	140
Replace a Pump	141
Replace Exhaust by-Pass Filters	149
Orifice Filter Inspection, Cleaning & Replacement	150
Clean the Touchscreen	152
Clean the Optics	153
Additional Information	154
Specifications	154
Detectable Gases	156
Maintenance Faults	162
Instrument Faults	166
Information Events	170
Transport Time	173
Manual Analyzer Override	174
Fix an Unresponsive Vertex Edge Touch Screen	175
Filter Compatibility	177
Nominal Transport Times	178

Replacement Parts & Consumables	178
Network Interfaces and Options	182
Register Map of Modbus TCP/IP	185
HMI PC Security Considerations	193
Warranty Statement	195
Contact Us	197

1 Safety

Read this information before you start using your device.

Trademarks

Brand or product names are trademarks of their respective owners. The following brand or product names are trademarks of Honeywell:

- Honeywell Vertex™ Edge
- Chemcassette®





General Safety



Follow all installation and operational instructions to ensure the safe and reliable operation of this unit. If this monitor is used in a manner not specified by Honeywell Analytics Inc., the protection provided by the equipment could be impaired.



WARNING: Do not connect or disconnect anything from the Power Distribution Unit (PDU) while energized.

Continuous Monitor Symbols

Symbol	Description
	Lifting instructions, low clearances, slipping/tripping hazards, minor corrosive dangers. Also used when defining personal protective equipment (gloves, dust masks, etc.)
	Personal injury risk: machinery hazards around guarded equipment, moving parts, crush/pinch hazards, flying debris, and arc flash hazards.
	The most dangerous or potentially lethal hazards: unguarded equipment, confined space entrances, and lockout labels.
	Caution: possibility of electric shock

Symbol	Description
	Caution: hot surface
	Protective conductor terminal (ground terminal)

EMC Considerations

Your Honeywell Analytics continuous gas monitor has been designed to comply with Electromagnetic Compatibility (EMC) standards applicable at the time of its manufacturing. The design includes filtering, shielding and bypassing techniques. At the time of certification, simulated customer Input/ Output (I/O) schemes were tested.

All methods used in your equipment for emission suppression and reduction of susceptibility are interactive. Modifications to the monitor could result in increased emissions and higher vulnerability to other radiated fields.

Following the guidelines in this EMC Considerations section will ensure your monitor maintains the enhanced degree of EMC integrity. The guidelines listed apply only to I/O emissions and do not apply to A.C. and D.C. monitor power connections.

FCC Compliance Statement

CAUTION: Changes or modifications not expressly approved could void your authority to use this equipment.

This device complies with Part 15 of the FCC Rules. Operation is subject to the following two conditions: (1) This device may not cause harmful interference, and (2) this device must accept any interference received, including interference that may cause undesired operation.

Industry Canada Statement

This device complies with Industry Canada licence- exempt RSS standard(s). Operation is subject to the following two conditions: (1) this device may not cause interference, and (2) this device must accept any interference, including interference that may cause undesired operation of the device.

Le présent appareil est conforme aux CNR d'Industrie Canada applicables aux appareils radio exempts de licence. L'exploitation est autorisée aux deux conditions suivantes : (1) l'appareil ne doit pas produire de brouillage, et (2) l'utilisateur de l'appareil doit accepter tout brouillage radioélectrique subi, même si le brouillage est susceptible d'en compromettre le fonctionnement.

China RoHS

部件名称	有害物质					
	铅 (Pb)	汞 (Hg)	镉 (Cd)	六价铬 (Cr(VI))	多溴联苯 (PBB)	多溴二苯醚 (PBDE)
印制电路板组件	X	0	0	0	0	0
线束及电镀连接组件	X	0	0	0	0	0
第三方电脑, 显示器, 开关, 集成器, 控制器	X	0	0	0	0	0
机械部件风扇, 马达等	X	0	0	0	0	0
外壳	0	0	0	0	0	0
金属零件	0	0	0	0	0	0
紧固件	X	0	0	0	0	0
管路系统	0	0	0	0	0	0

本表格中未列出的所有部件和配件包含的有害物质均没有超过 GB/T 26572 所要求的限制。

本表格依据 SJ/T 11364 的规定编制

0 : 表示该有害物质在该部件所有均质材料中的含量均在 GB/T26752 规定的限量要求以下。

× : 表示该有害物质至少在该部件的某一均质材料中的含量超出 GB/T26572 规定的限量要求。

Vertex Edge_RST_1, 25 August 2020

Cabling

Braid	Must have a minimum 65% coverage
Foil	When used with braid, provides 100% coverage. Do not use foil alone. It has a tendency to break.
Stranded Pair	Provides the greatest surface area
Shield Termination	Continuation of the shield to the cabinet earth ground is most important. For discrete wire terminations, pigtailed to the cabinet (connector) ground should be extremely short (no greater than three inches). For multiconductor connector terminations, only 360° shielded shells should be used.

Note: Honeywell Analytics product testing uses >65% braid with foil (around the bundle); twisted pair; stranded 24 AWG (minimum wiring for all qualification and certification testing.)

Connectors

Failure to properly secure the connector to the equipment will result in high emission levels. Also, poorly constructed or improperly assembled connectors can be a high source of radiated noise and provide a path for external signals into the monitor.

Ethernet cables longer than 30M need to be shielded. Ethernet cables less than 30M can be unshielded.

2 Introduction

System Overview

The Honeywell Vertex™ Edge System continuously monitors up to 72 remote locations for toxic gases. It responds to gases that exceed programmed levels by:

- Triggering alarms and opening event windows to warn operators of high concentrations;
- Displaying the location, gas type and gas concentration; and
- Storing the alarm information in a database.

The Vertex Edge System provides fast response to a wide range of gases. Each location may be up to 400 ft (122 m) from the Vertex Edge System. The system uses one or more of Honeywell Analytics' Chemcassette® analyzers to provide a monitoring system tailored to meet the requirements of the facility.

The Vertex Edge System incorporates a range of redundant and protective features for maximum uptime:

- Pumps are redundant;
- The system powers up in the same state as when powered down;
- A single analyzer can exit monitoring when replacing filters, Chemcassettes, and significant components without impacting the other analyzers.

Operation can be through an LCD touch screen or through a local area network (LAN).

Chemcassette® is a registered trademark of Honeywell Analytics, Inc.

System Components

The following photos illustrate the Vertex Edge System views, ports, connections and controls.

Front view

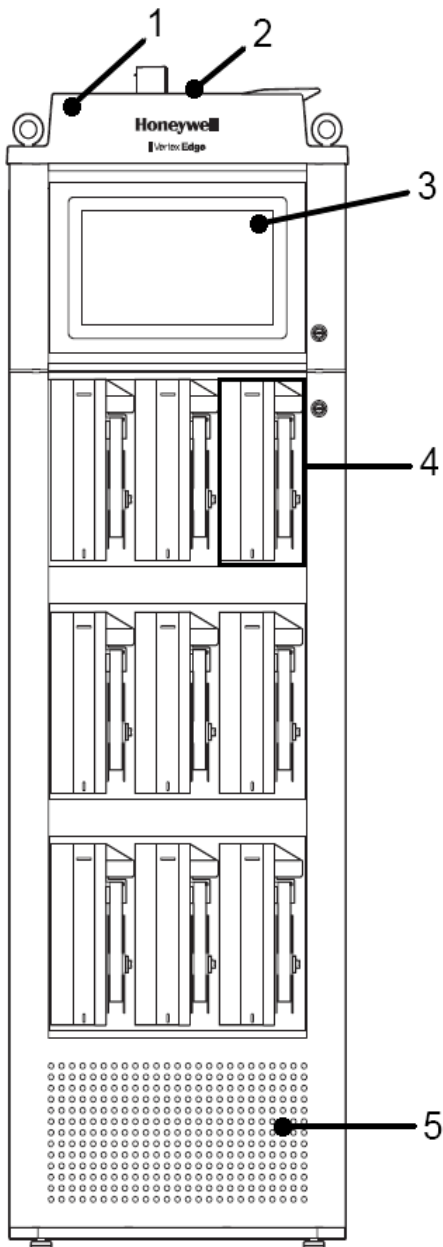

1. Sample tubing connections
2. Exhaust and wiring port
3. System controls (behind screen)
4. Analyzer
5. Pump

Back view

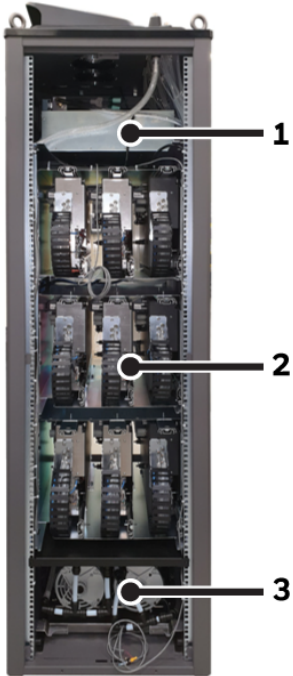

1. Smart power distribution unit
2. Analyzer
3. Pump

Exhaust and wiring ports

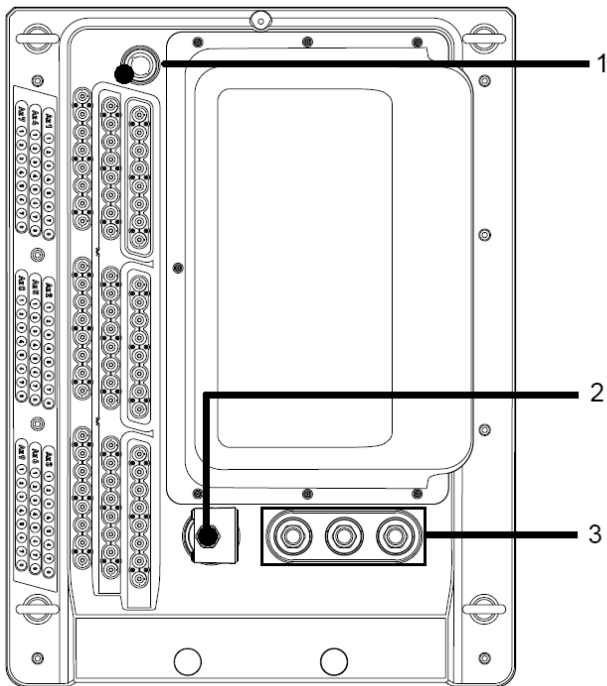

1. System Exhaust 0.5 in (12.7 mm) tubing
2. AC Input 0.75 in pipe thread
3. Alarm Wiring Conduit Plates - 1.5 in (38.1 mm) x 3

NOTE: Please note that exhaust tube is push to connect.

Module Front - Door Closed

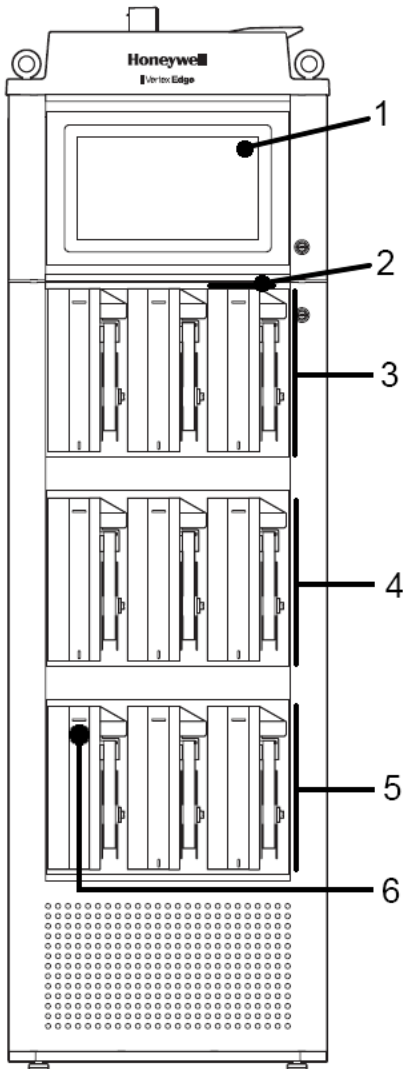

- 1. Protective panel over touch screen
- 2. Analyzer Slot
- 3. Tier 1
- 4. Tier 2
- 5. Tier 3
- 6. Analyzer Status LED

Analyzer side panel – Exterior

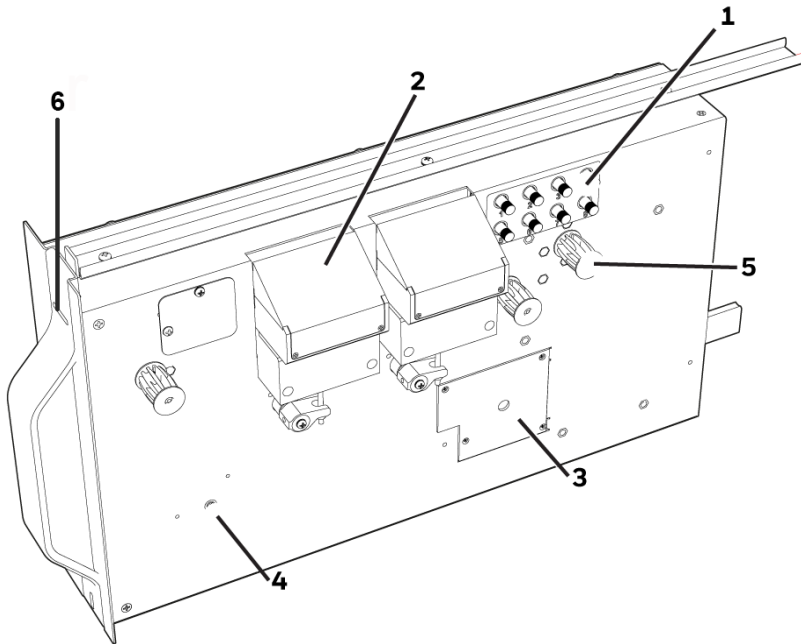
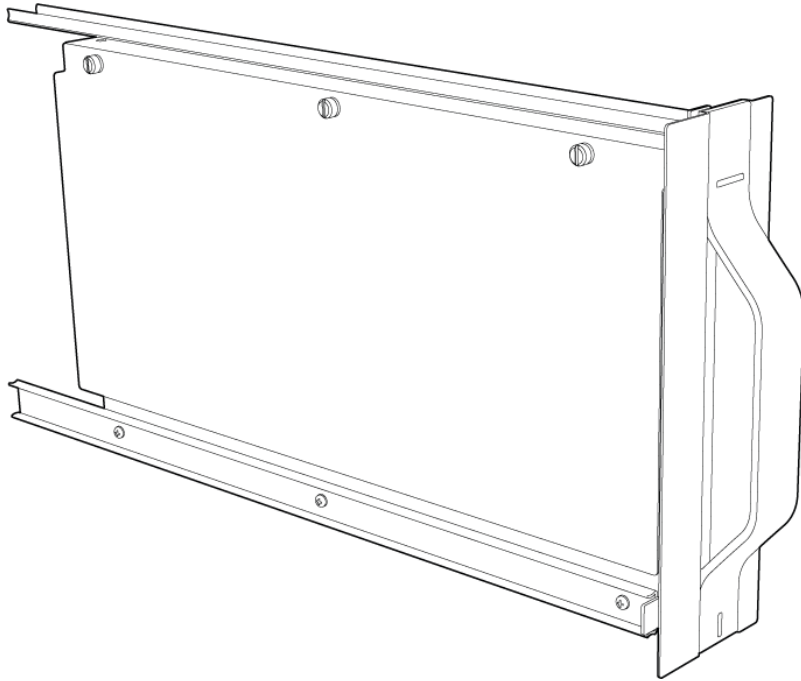

1. Needle Valve for flow adjustment
2. Optics Block
3. RFID reader
4. Take-up reel
5. Tape encoder roller
6. Status LED

Analyzer side panel – Interior

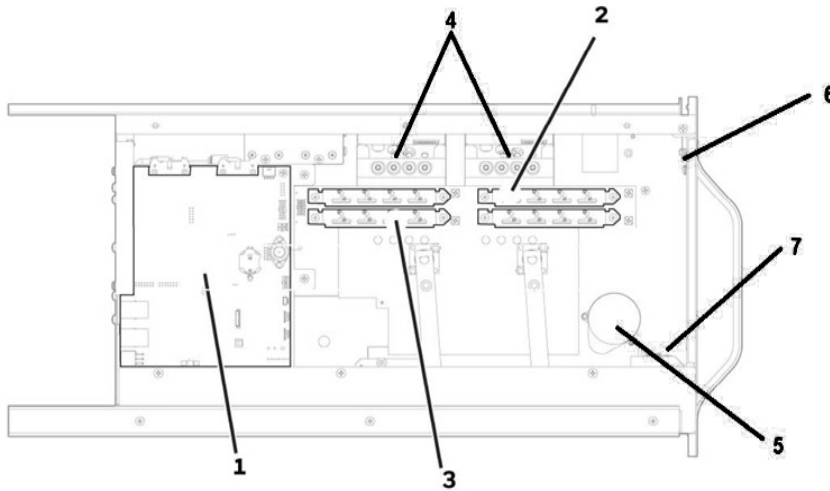

1. Analyzer Main Board
2. Sample pressure transducers
3. Sample flow transducers
4. Optic blocks
5. Tape advance motor
6. Status LED
7. Locking solenoid

Sample tubing connections

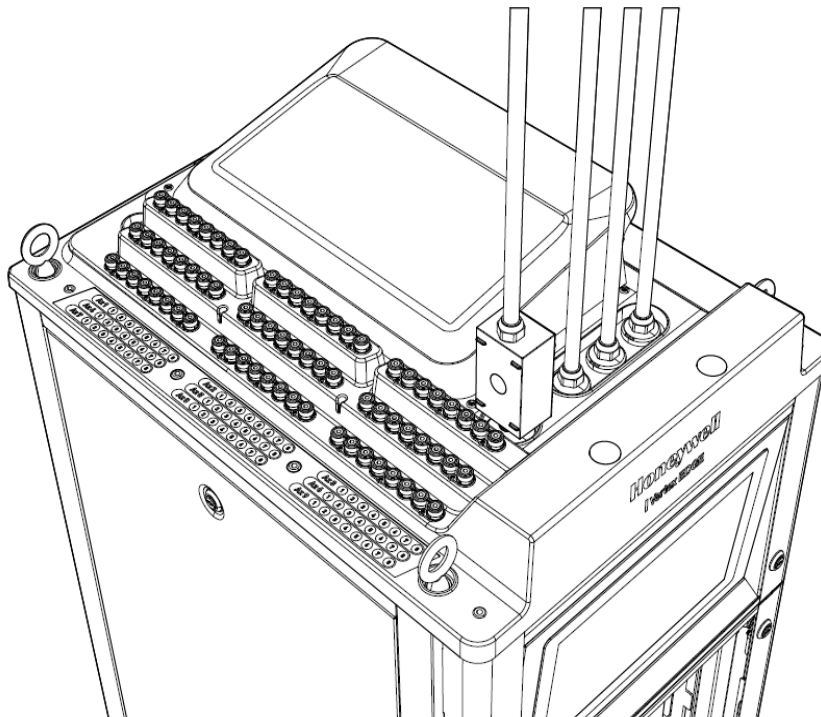

Smart Power Distribution Unit

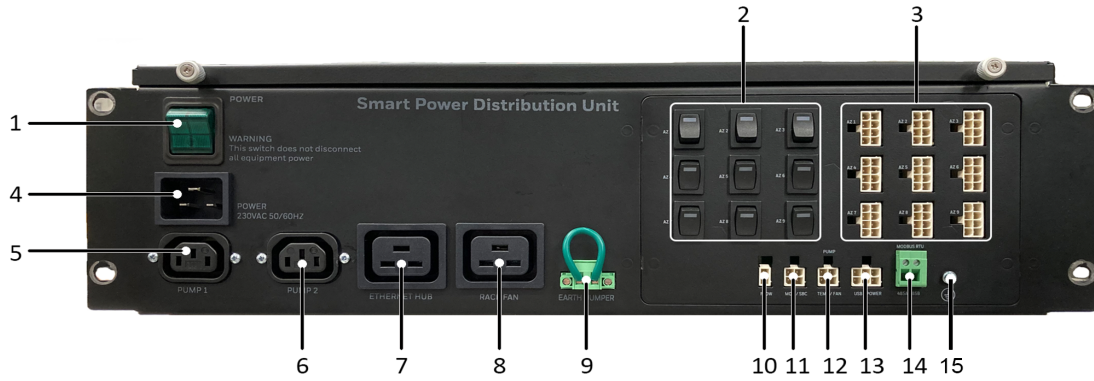

No.	Description	No.	Description
1	Main Power ON/OFF Switch	8	Rack Fan Power Connector*
2	Analyzer Power Switches	9	Earth Jumper (DO NOT REMOVE)
3	Analyzer Connectors	10	Exhaust Pressure Switch
4	Main Power Connector*	11	Monitor/Computer power
5	Pump 1 Power Connector*	12	Pump Over temp sensor / Fan power
6	Pump 2 Power Connector*	13	Not Used
7	Ethernet Hub Power Connector*	14	Modbus RTU
15	Modbus RTU Ground Screw		

* AC connections

System Control Unit

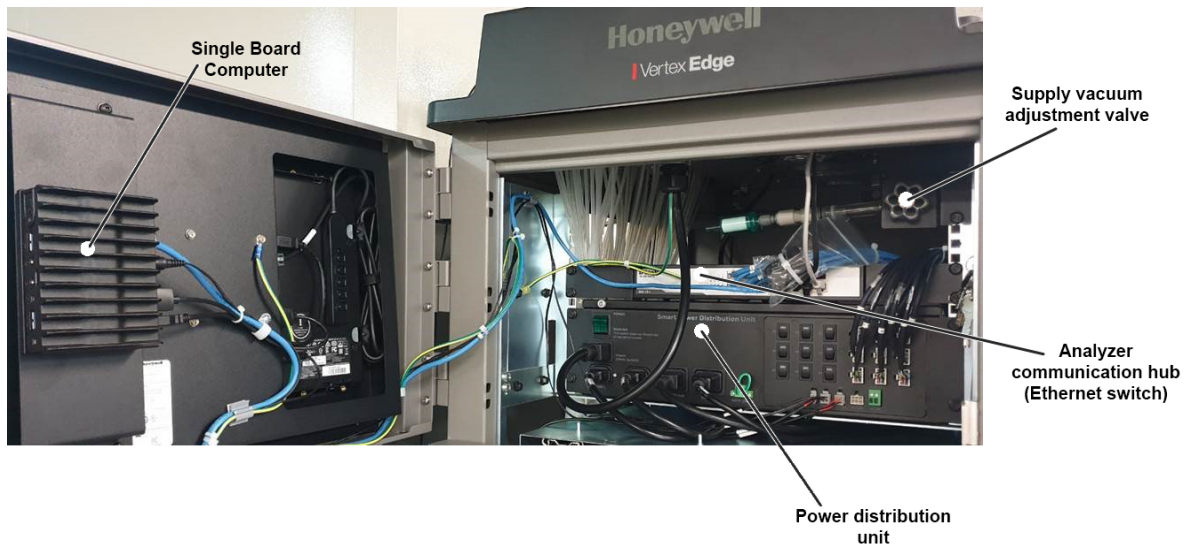

Analyzer – Front view

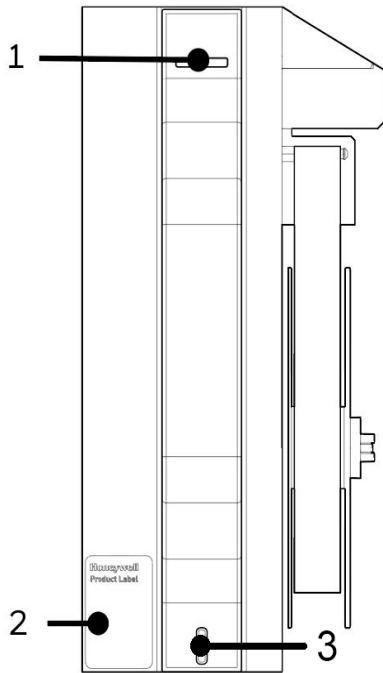

1. Analyzer status LED
2. Product label
3. Analyzer Release Slot

Back of Analyzer

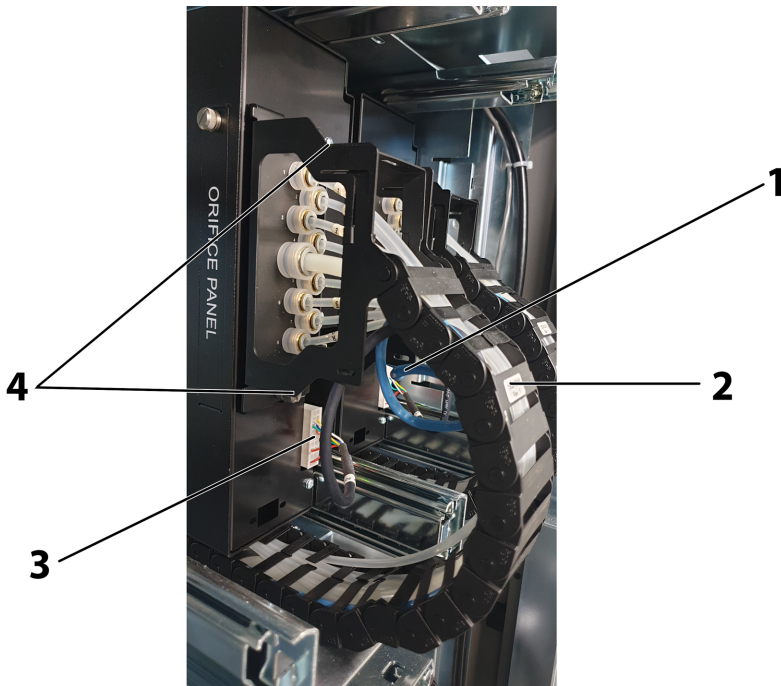

1. Internal Ethernet Communication Cable
2. Tubing Harness
3. Analyzer Power Connection
4. Securing screws for tubing harness

Chemcassette

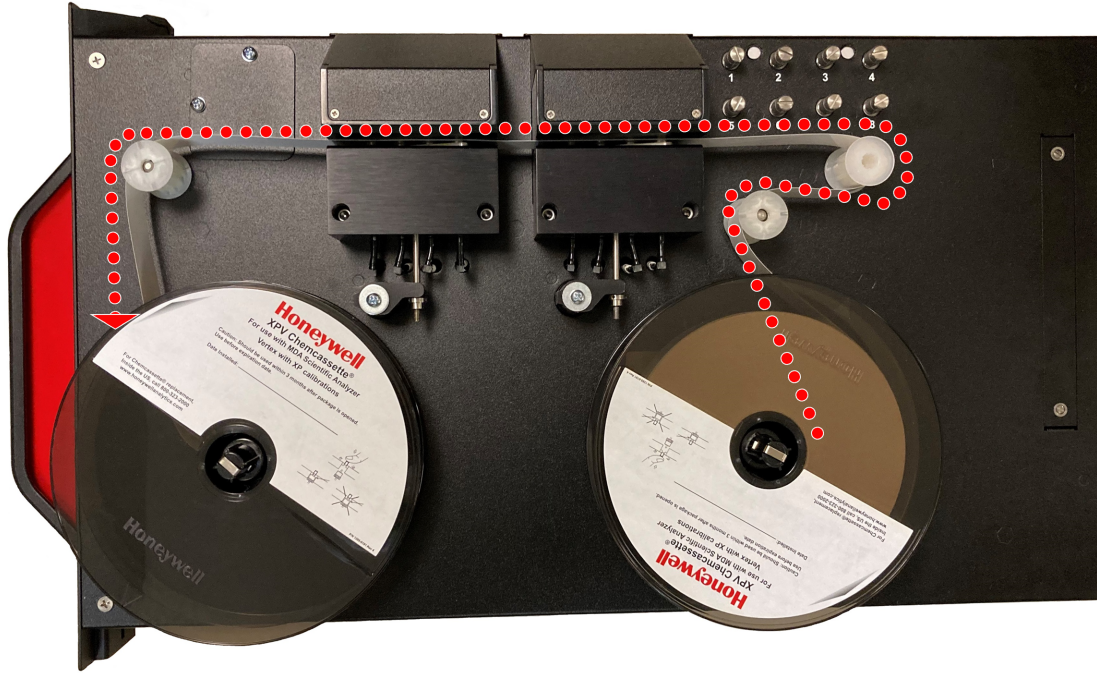

1. Chemcassette directional flow

Analyzer Modules

The Vertex Edge System is populated with up to nine universal analyzer modules. Modules are installed in slots on one of three tiers. Each tier includes three slots for a total of nine slots in a Vertex Edge System. Analyzer modules occupy one slot each.

Tier 1	CC	CC	CC
Tier 2	CC	CC	CC
Tier 3	CC	CC	CC
	Slot 1	Slot 2	Slot 3

	Number of Points	Installed into Slots	Total Possible per Vertex Edge System
Analyzer	8	1, 2 or 3	9

Sampling System

Each Analyzer module is a monitoring center for sampling lines from sample locations. As they apply to the Vertex Edge System, the words point, line and location require definition:

- A location is a place to be monitored
- Sample atmosphere runs from the location to the Vertex Edge System via a line
- Each of the 72 sample tubing connections on the Vertex Edge System corresponds to a point. A sample line can be connected directly to a single point or multiple points.

The system draws air simultaneously from all locations. Two different types of flow are:

- Transport flow: high-velocity, large-volume air movement through the lines
- Sample flow: air admitted to the Chemcassette® detection system

The high speed of transport flow allows rapid monitoring and response time when using long lines from monitored locations to the Vertex Edge System. A small portion of the transport flow (sample flow) is analyzed to determine concentration levels.

The complete sampling and monitoring system consists of the following components:

- Sample lines to all monitored locations
- Flow connections through quick-connect ports in bulkheads on top of unit
- Moving cable and connectors
- Vacuum pumps

- Analyzers incorporating manifolds, Chemcassette and no filters
- Flow controlling manual needle valve
- Top exhaust port

There are 72 inlets, one for each monitored location. One exhaust port is also located on top of the Vertex Edge cabinet.

Chemcassette Detection System

The Chemcassette Analyzer module is a self-contained, microprocessor-controlled analyzer that occupies one slot in a Vertex Edge tier. Sample lines and the vacuum source are connected to the Chemcassette via a single 9-tube connector to develop a better stain for better sensitivity and reliability.

The system powers up in the same state as when powered down. Data is stored in the module's memory until the data acquisition computer retrieves it.

The Vertex Edge Analyzer modules use the Honeywell Analytics Chemcassette optical detection system. Analyzer modules sample and detect a specific gas or family of gases.

Each eight-point Analyzer module manages Chemcassette tape transport, provides optical detection of stain, directs sample flow through the Chemcassette to develop a better stain for better sensitivity and reliability, and stores event data for retrieval by the data acquisition computer.

Components of the detection system include:

- Chemcassette detection tape
- Optics and electronics for the detection system
- Chemcassette tape transport mechanism
- Manual adjustment needle valve

Detector Optics

The heart of the Chemcassette module is an optical detection system that measures a stain that develops on the Chemcassette tape in the presence of a target gas. Each eight-point Analyzer module has two detection heads, each with four individual detectors.

Stain Pattern

The following chart shows the stain pattern of sample detection on the Chemcassette tape.

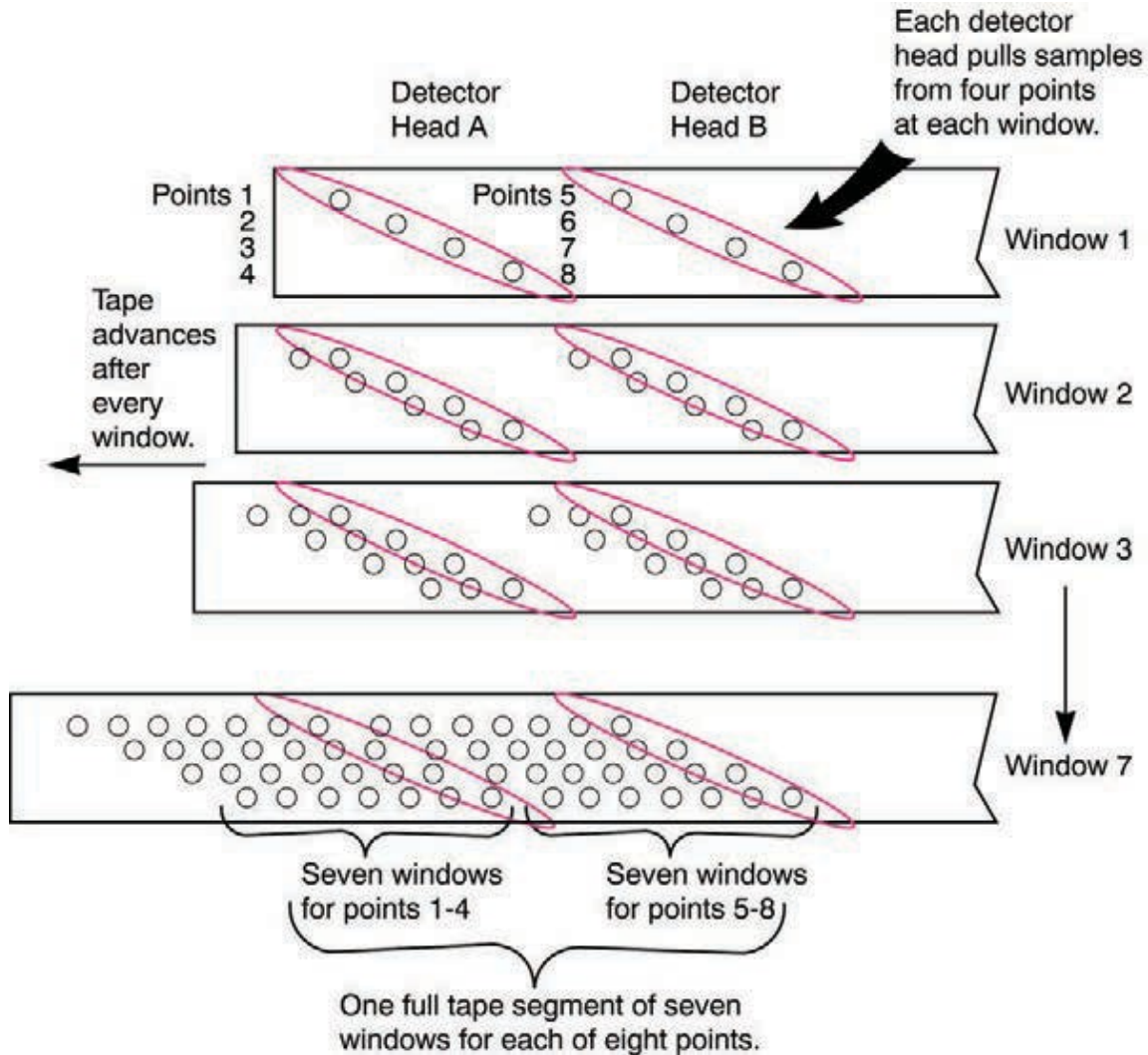

When monitoring a location, the system detects and measures a specific gas or a family of gases in the sample. The microprocessor in the analyzer module interprets the data and responds appropriately.

In the Closed Loop Optics (CLO) detection system, a reference detector monitors and controls the intensity of the LED.

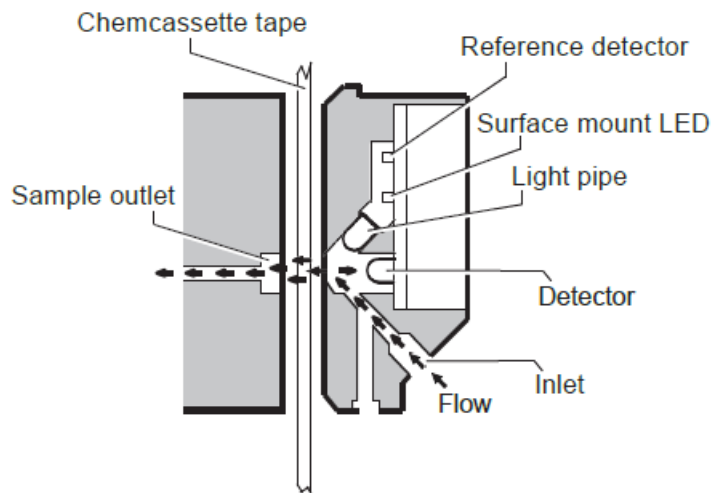

The microprocessor in the Chemcassette analyzer module interprets the stain. It then calculates and reports a precise concentration level to Daq PC or external system. Gas concentrations are reported in parts-per-million (ppm), parts-per-billion (ppb) or milligrams-per-cubic-meter (mg/m³).

Chemcassette Tapes

Chemcassette tapes are tagged with a radio frequency identification (RFID) tag to automatically identify the following:

- Serial number
- Gas family/ tape type
- Revision level
- Expiration date of the tape
- Chemcassette® leader parameters

The module uses a leader on the Chemcassette tape to allow calibration of the optics every time a new tape is installed.

Vacuum Pumps

Two field-replaceable pumps provide a redundant vacuum source for the transport and sample flow system. One pump in the system draws vacuum while the other is idle. The pump exhaust connects to the manufacturing facility central toxic exhaust system.

Note: The exhaust line from the Vertex Edge should not exceed 50 feet.

The pumps are located in the bottom of the Vertex Edge System cabinet on a sliding plate to help disconnect the tubing for ease of maintenance. Three cooling fans circulate air over the pumps.

The Vertex Edge System draws cooling air in through a filter mounted on the pump module access door.

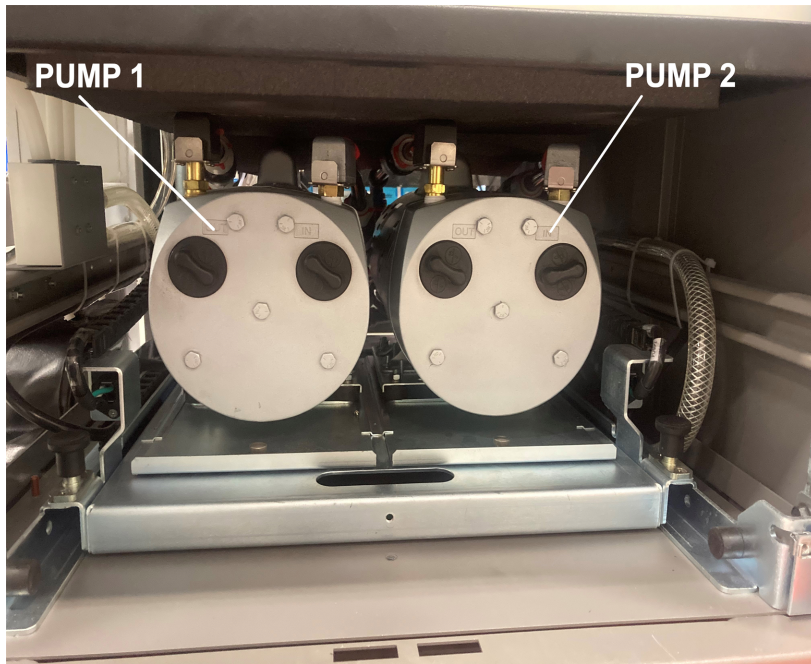

Multiple Gas Monitoring

A Vertex Edge System equipped with Analyzers can monitor more than one gas (or groups of gases such as hydrides or mineral acids) at a location.

Each Vertex Edge Analyzer module can monitor only one gas family (such as hydrides or mineral acids).

Control Systems

The Vertex Edge control system consists of a central data acquisition computer (DAq), and one or more analyzer modules.

Following is a simplified block diagram of the communications path of the control system. The analyzer modules are microprocessor controlled and contain non-volatile memory.

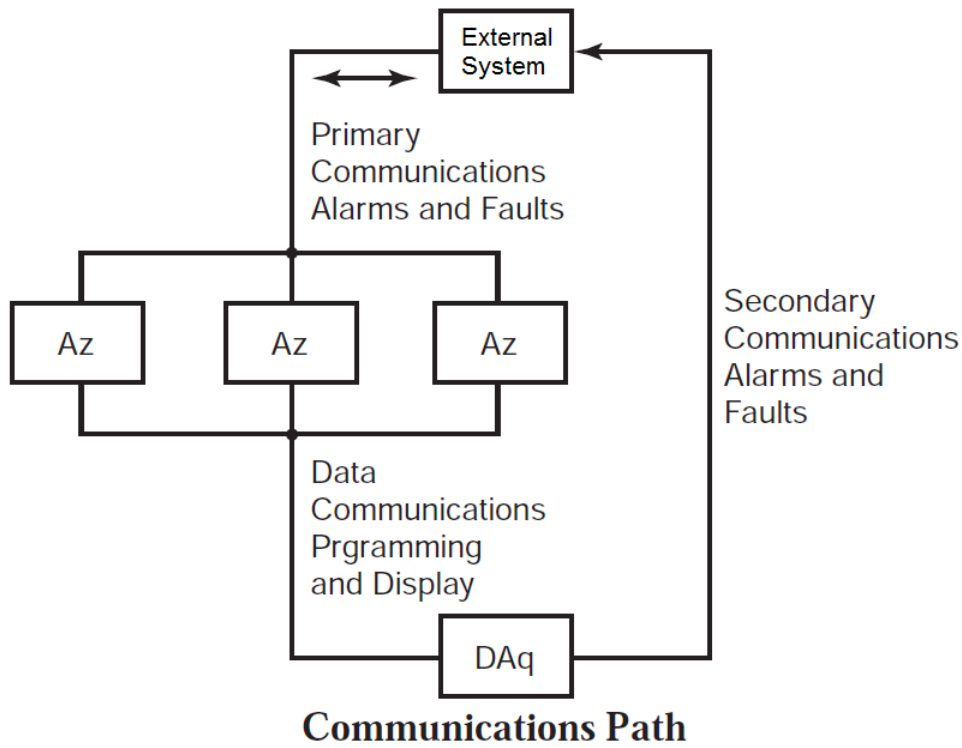

Data Acquisition Computer

The data acquisition computer (DAQ) is the central processor for the Vertex Edge System. It configures the analyzers, stores data and provides a network interface for data transfer to other computers.

System display and operator control is through an on-screen keyboard.



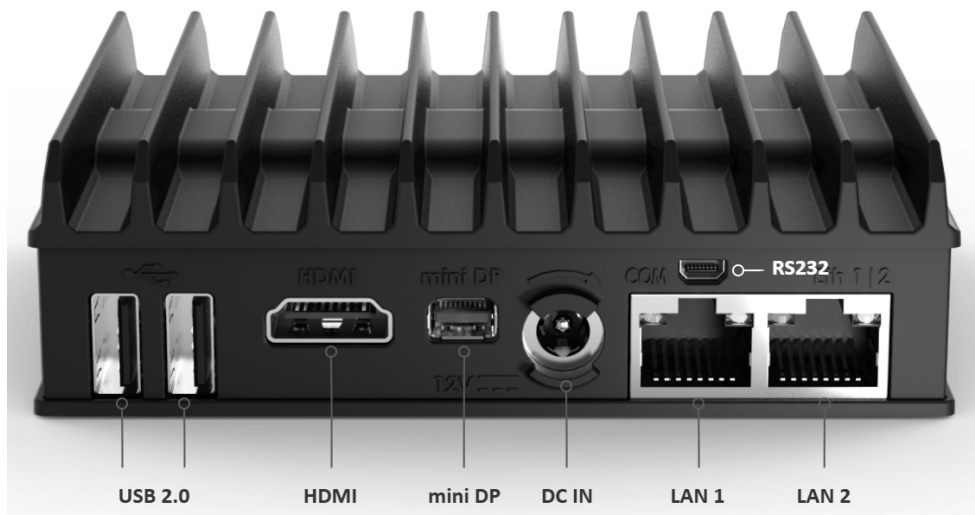

1. External Ethernet Network (Modbus TCP/IP, Web server)
2. Touch USB cable
3. HDMI cable
4. Power jack (DC-IN)
5. Internal Ethernet to network switch

Please note: when using the USB 3.0 ports to connect a USB flash drive, please use caution when closing the panel door with this installed. If the drive is physically too large, it can become damaged when closing the door. Do not use the USB 2.0 ports.

NOTE

Operator must be grounded before accessing the USB 2.0 ports.

3 Installation

The installation procedure for the Vertex Edge System consists of six steps:

1. Surveying the Installation Site;
2. Optional Floor Mounting;
3. Installing Sample Lines;
4. Installing Pump Exhaust Line;
5. Electrical Power;
6. Data Acquisition System.

Installation Step 1: Surveying the Installation Site

A survey of the site helps you to make important decisions before installing your Vertex Edge System. Topics in this section are intended to assist you with appropriate placement of the Vertex Edge System and in determining if you have special filtering needs at the sampling location.

The site should:

- Be remote from the monitored location;
- Have sufficient ventilation for cabinet cooling;
- Have power available; and
- Be indoors in an area that is not subject to wide variations in temperature and humidity.

Note: The humidity is 20-65% RH and a temperature between 59°F to 95°F (15°C to 35°C).

Placement of the Vertex Edge System

Install the Vertex Edge System in an environmentally-protected site remote from the manufacturing or storage locations that it monitors.

You can place the Vertex Edge System away from sample locations with sample tubing up to 400ft. (122m) length.

Exposure to Dust and Humidity

Exposure to corrosive gases or materials, excess moisture, dust and other unusual environmental conditions could seriously hamper the unit's monitoring ability and could cause damage to it.

Allow room around the Vertex Edge System for ventilation and servicing.

Sample Transport Time

The shorter the sample line, the shorter the transport time. If monitoring a critical location, it may be desirable to place the monitor near that critical area to reduce sample transport time for that location.

Monitor Dimensions

Monitor dimensions are important factor in monitor placement. The Vertex Edge System is 24 in. (61 cm) wide, 34-1/2 in. (88 cm) deep and 76 in. (193 cm) in height. The system with 9 analyzers weights about 900 pounds (408 kg). Allow for 24 in. (61 cm) door swing; 5 in. (12.3 cm) at rear and 5 in. (12.3 cm) on sides. Allow clearance above the monitor for installing sample lines.

Sample Locations

Before installing the Vertex Edge System, evaluate the sampling locations to determine the presence of excessive dust or moisture. An external filter must be used in all locations. Make sure you use the correct filter. Dust may be a result of construction as well as manufacturing activities. Moisture may result from rain entering a line at an outdoor sampling location or from condensation caused by temperature fluctuations. Water condensation in the sample lines could cause false alarms.

Note: Variables such as airflow, the molecular weight and temperature of the sample gas, and the physical conditions of the areas being monitored influence the placement of the sampling locations. You may need to consult your company's industrial hygienist or safety officer before installing sample lines to determine your company's policy related to sampling locations and monitoring of the desired sample gas.

Sample Line Particulate Filter Use

See Specifications, to determine which filter type should be used at the location.

Installation Drawings

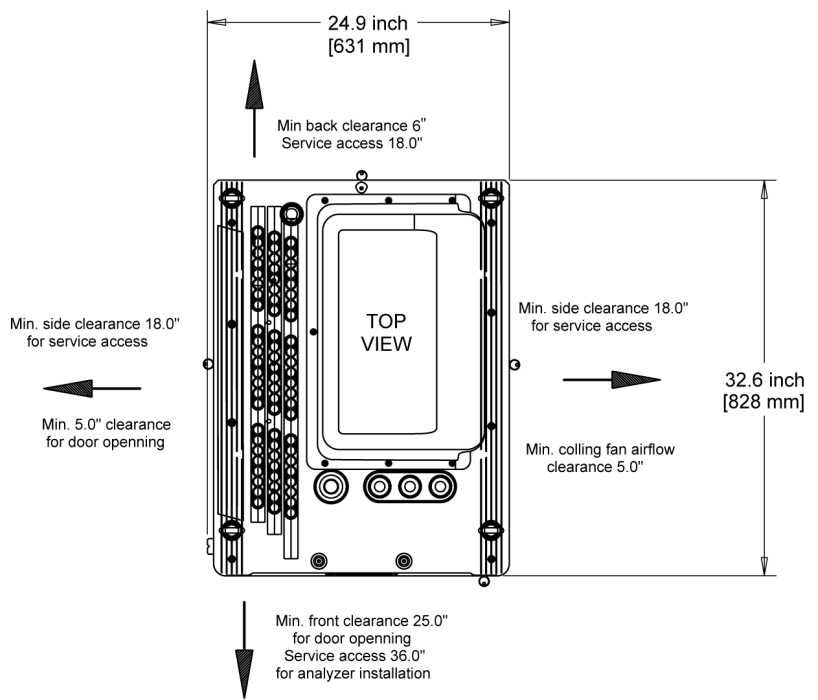
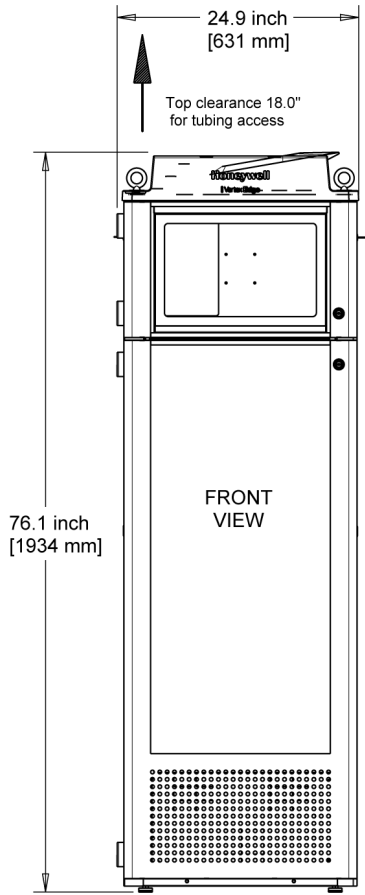

FLOOR SPACE REQUIREMENT
Some service procedures may require access from any side

Optional Installation Step 2: Floor Mounting

1. Attach the bracket to the front and rear of the Vertex Edge cabinet, including the supplied hardware.
2. Anchor the bracket to the floor with the appropriate mounting hardware base on installation (hardware not provided).

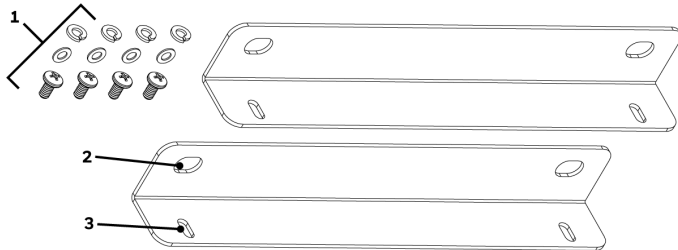

1. Cabinet hardware
2. Floor
3. Cabinet side

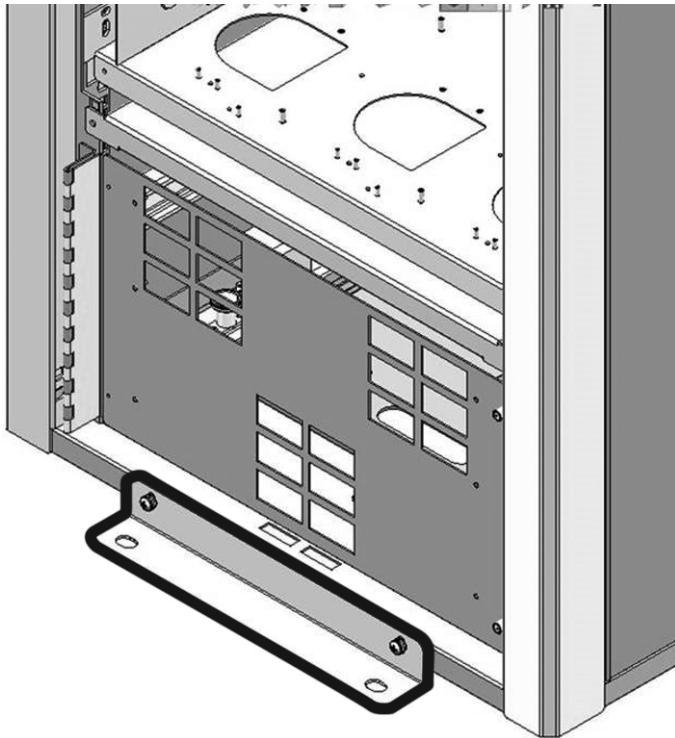

Installation Step 3: Installing Sample Lines

Use only FEP Teflon® tubing to assure proper sample transport. Other types of tubing are not sufficiently inert. See Specifications, for tube specifications. FEP tubing can be ordered from Honeywell Analytics.

Install sample lines from each location to the top of the Vertex Edge System. This procedure involves:

- Sample Line Installation Requirements
- Sample Line Connections
- Installing Sample Line Particulate Filters

Honeywell Analytics supplies FEP grade Teflon tubing with all new monitors. This tubing is manufactured to our own strict specifications and has been purged of all byproducts of the manufacturing process. On occasions, users have supplied their own FEP type tubing. Should you choose to use your own tubing, be advised that some brands of FEP tubing off-gas small amounts of HF, which can be detected on start up by Honeywell Analytics monitors configured for detecting mineral acids gases (HBr, HCl, HF, NF₃). Before enabling building alarm systems, make certain that 1) you have installed the correct Chemcassette, and 2) your monitor reads zero.

1/4 in. (6.35 mm) O.D. x 0.190in. (4.83 mm) (Thin wall)

Sample Line Installation Requirements

Follow the general requirements listed below when installing sample lines.

- Sample lines should not exceed 400 ft. (122m) in length.
- Route all lines as direct as possible to improve transport time.
- Avoid running sample lines through areas of great temperature extremes, such as adjacent to steam or chiller lines.
- Sample lines should not be crimped, bent to less than a 12 in. (30.5 cm) radius, or placed in an area where weight could collapse the tubing. Sample lines should be easily accessible for periodic inspection.
- Where possible, leave as many bends exposed for periodic visual inspection of the line for kinked or damaged tubing.
- Check each sample line installation for seal integrity after completing installation of the Vertex Edge System. See Leak Checking Sample Lines, for the leak check procedure. Also use this procedure to detect leaking or severed tubing after events, such as construction, which may have affected the integrity of the tubing.
- Analyzers with unused points require a filter. Filter kit 1295A0702 is recommended.
- If an analyzer is installed in the Vertex Edge with a Chemcassette tape, the optics may need cleaning before activating a previously unused point(s).
- Unused analyzer slots should have a plug installed for each point. These are included during shipment

Sample Line Connections

To prepare for installation of sample lines, remove the FEP Teflon tubing from the installation kit. The top of the unit includes 73 connections:

- 72 Sample Inlets (Point legend follows and is in proper sequence.)
- Exhaust Outlet (See Installing Pump Exhaust Line, for connection.)

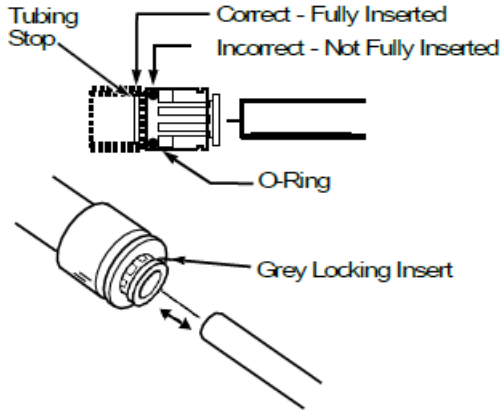

Sample Line Inlet Connections

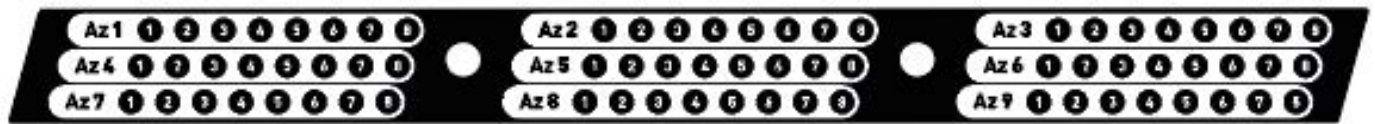

Note: Always perform a leak check after installing sample lines. See Leak Checking Sample Lines, for the leak check procedure.

Each inlet has a quick connect/disconnect fitting with an internal O-ring and an external grab ring. To install a tube into a sample line inlet, insert the tube far enough into the fitting to ensure that the tube has passed through both the external grab ring and the internal O-ring and is firmly seated against the stop. The insertion depth for a correctly installed sampling line is 1/2in. to 5/8in. (12 mm -16 mm). There is an insert depth guide hole near the inlet ports. To verify the insert depth, insert the tube into the guide hole far enough to touch the end and mark the length. Remove the pipe to measure the insertion depth.



CAUTION

Improper installation of the tube into the connector results in dilution of the sample.

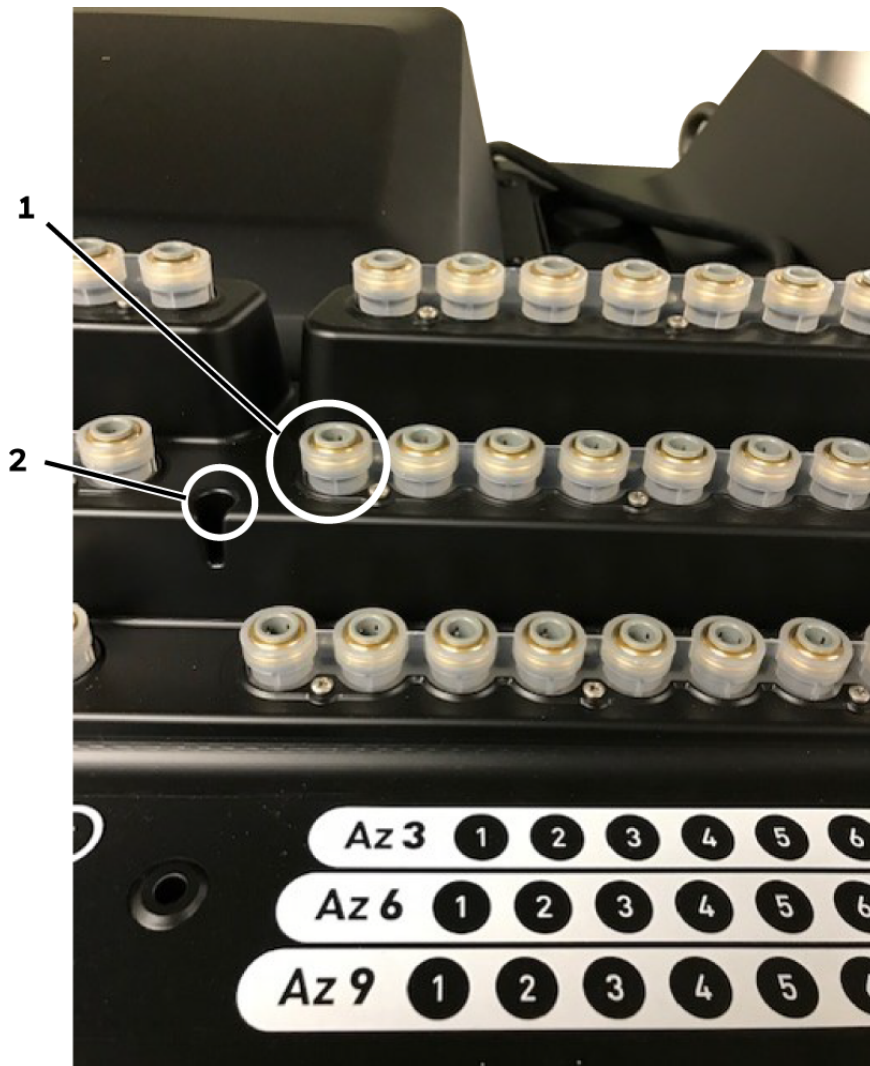

1. Sample Point Feeding
2. Depth Gauge

Installing Sample Line Particulate Filters

Attach a sample line filter to the sampling end of the line for all locations.



CAUTION

Excess amounts of dirt in the filters reduces the sample flow, raises sample vacuum and may affect concentration readings of the analyzer.

See Specifications, to determine the proper filter type to use with each target gas.

Installation Step 4: Installing the Pump Exhaust Line

This section describes exhaust connections and installation. The Vertex Edge is equipped with a vacuum pump located at the bottom of the Vertex Edge cabinet. The pump exhaust line connects to the manufacturing facility central toxic exhaust system.

Exhaust Line Installation Requirements

Follow the general requirements listed below when installing exhaust lines.

The length of the line should not exceed 50 ft. (15 m). If longer distances are required, contact Honeywell Analytics.

Do not crimp exhaust lines or place them in an area where weight could collapse the tubing or bend them to less than a 12 in. (30.5 cm) radius.

Where possible, leave as many bends exposed for periodic visual inspection of the line for kinked or damaged tubing.

Varying exhaust pressure can induce pump failure or flow faults.

Exhaust Line Connection

The instrument includes 50 ft. (15 m) of 0.375in. (10mm) I.D. x 0.5in. (13 mm) O.D. Teflon or Polypropylene tubing. Insert the tubing into the exhaust port on the top of the unit to the depth of 0.9in. (23mm).



CAUTION

Leaks in the exhaust tubing connection can cause exposure to toxic gases from remote sample areas.

To ensure a leak-free installation:

- Use a polypropylene tube with outside diameter 0.375in. (9.525mm) +/-0.005in. (0.127mm).
- Verify that the external surface of the tube is free of score marks and scratches that could compromise the O-ring seal used in the fitting over the insertion depth.
- Cut the tube end perpendicular to its length 0.062in (1.5mm) from its end.
- Insert the tube in the fitting to a depth of 0.95 in.(24.13mm) ±0.05in. (1.27mm)

With the system running, verify the leak integrity by plugging a sample point and monitor sample point flow via HMI point flow screen.

Installation Step 5: Electrical Power

AC Source Requirements: Operating Voltage: 230 VAC \pm 10% (under load) @ 50/60Hz; 15 Amps maximum, single phase.

The Vertex Edge system requires a dedicated AC source rated at 230 VAC @ 50/60Hz, 15 Amp single phase providing hot, neutral, and ground lines. Line voltage should fluctuate no more than \pm 10%. The external switch must be clearly labeled and installed in accordance with local electrical codes. Input power cable should be #14 AWG minimum. The safety ground wire must be the same or larger gauge as the line wires. Connect AC power connection to the two-position terminal block in the rear panel of the power module. Connect ground wire to the threaded stud on the side rail of the rack.

NOTE

Testing has shown that using 208/220VAC phase-to-phase power source instead of the recommended 230VAC phase-to-neutral, can result in voltage excursions on the system ground. The excursions can cause damage to components in the analyzers. This type of damage is most likely to occur during system power cycles or in cases where the supply power is not a clean source. For applications where 230 VAC single phase power is not available, Honeywell Analytics offers transformers to provide the necessary power.

NOTE

It is important to verify that all 5 of the AC connections to the PDU are fully connected. This needs to be done before power up. Refer to See "System Components" on page 11 for more information. to identify these 5 AC connections.

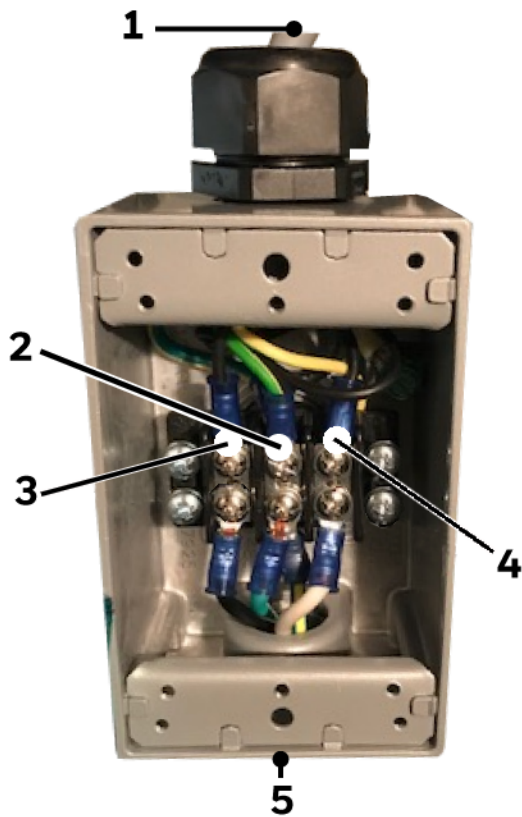

1. To power outlet. The customer connects it.
2. Green Ground.
3. Black Live line
4. White Neutral
5. Vertex Edge side, prewired.

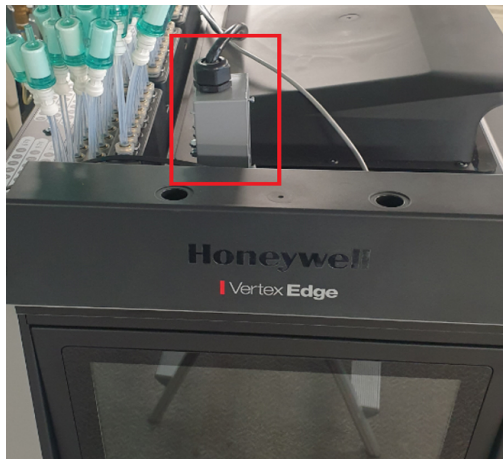

Verifying Proper AC Power Connection

Before powering up the Vertex Edge system, verify the connections using a multimeter to determine the connections are correct and correct voltages are present at the power connection.

Verifying Line Connection

Touch the red multimeter lead to the line/hot connection and touch the black lead to the ground lug. The meter should display a voltage verifying the presence of 230 VAC.

Verifying Neutral Connection

Touch the red multimeter lead to the neutral connection and touch the black lead to the ground lug. The voltage value should not exceed 5 VAC.

Verifying Operating Voltage

Touch the red multimeter lead to the line/hot connection and touch the black lead to the neutral. The meter should display a voltage value of 230 VAC \pm 10%.

NOTE

All panel locks need to be in the lock position in order for rack to be properly grounded.

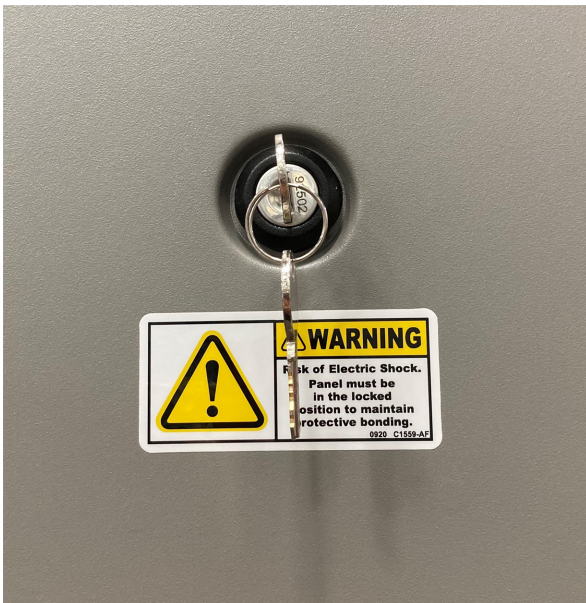

NOTE

Shown is the locked position, which provides ground to the panel.

NOTE

After confirming line and neutral connections and the operating voltage is within the specified range, power up the Vertex Edge® and check the operating voltage again to assure the voltage under load is within the specified range for safe operation.

Vertex Edge Transformer Installation

The directions and diagrams enclosed herein are intended to illustrate the proper installation and wiring of transformers designed to step-down or step-up site voltage to proper levels for

Vertex Edge operation. The information provided has been gathered from Sola/Hevi-Duty for use with their products as specified in this document.

These instructions are for high voltage equipment operating life safety equipment. Only qualified electricians or approved Honeywell Analytics service representatives should perform these tasks. Honeywell Analytics is not liable for any damages caused by incorrect installation by unauthorized or unqualified third parties, of electrical apparatus to the Vertex Edge monitor

Design Characteristics

- UL-3R enclosures for indoor and outdoor service
- Electrostatically shielded for quality power on sizes 1 KVA and larger
- UL class 180°C insulation system, 115°C temperature rise under full load
- Conduit knockouts for side entry into wiring compartment
- Copper lead wire terminations
- Units are encapsulated with electrical grade silica sand

Design Style

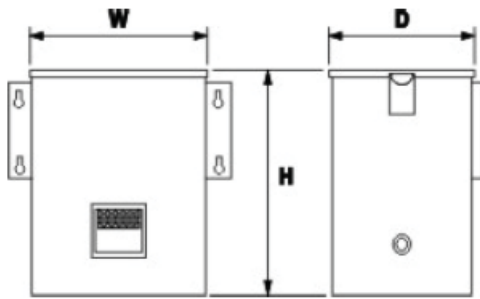

HA Part Number	Catalog Number	KVA	H	W	D	Ship Wt
0060-1020	HS5F5AS	5	17	14	9	104
0060-1021	HS12F5AS	5	17	14	9	104

HA Part Number	Primary Amps	Secondary Amps
0060-1020	20.8/10.4	41.6/20.8
0060-1021	18.0	41.6/20.8

Step-Down Wiring

0060-1020 as Step-Down Transformer 480v to 240v 240 x 480 Volt Primary, 120/240 Volt Secondary, Taps: 2, 2½% FCAN & FCBN

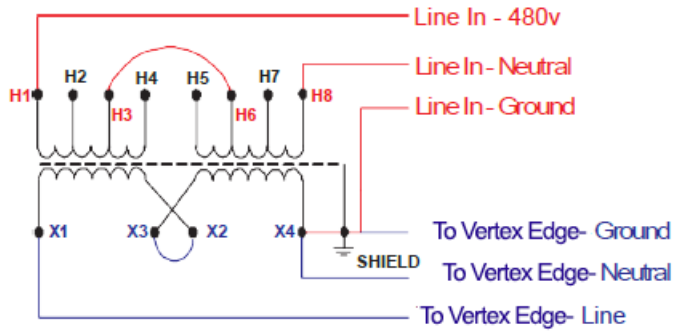

Single 480VAC Line In

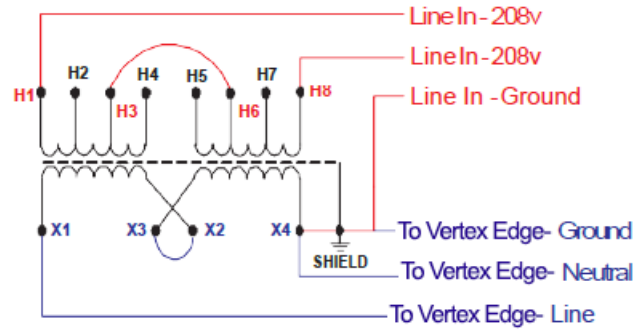

2 208VAC Lines In

Primary Voltage	Interconnect	Connect Lines to:
480	H3 to H6	H1 and H8
Secondary Voltage	Interconnect	Connect Lines to:
240	X2 to X3	X1 and X4
Connect X4 to Ground and Shield		

Set-Up wiring

0060-1021 as Step-Up Transformer 208v to 240v

120/208/240/277 Volt Primary, 120/240 Volt Secondary, Taps: None

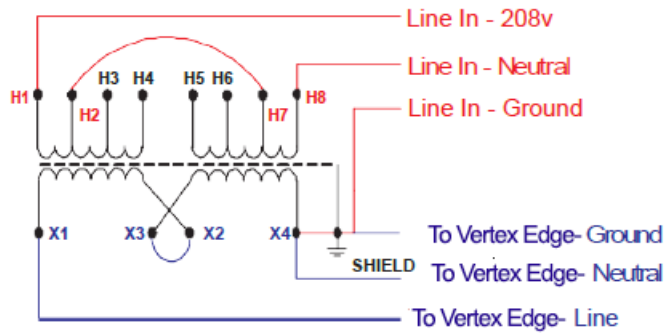

Single 208VAC Line In

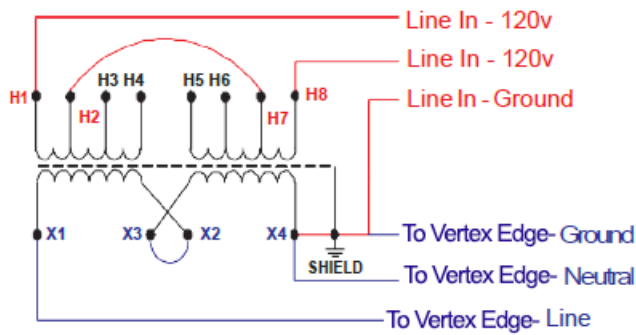

2 120VAC Lines In

Primary Voltage	Interconnect	Connect Lines to:
208	H2 to H7	H1 and H8
Secondary Voltage	Interconnect	Connect Lines to:
240	X2 to X3	X1 and X4
Connect X4 to Ground and Shield		

Overcurrent Protection

Example 1. Primary protection only is required if the transformer is single-phase and the secondary has only two wires. Overcurrent protection rating and location are shown as follows.

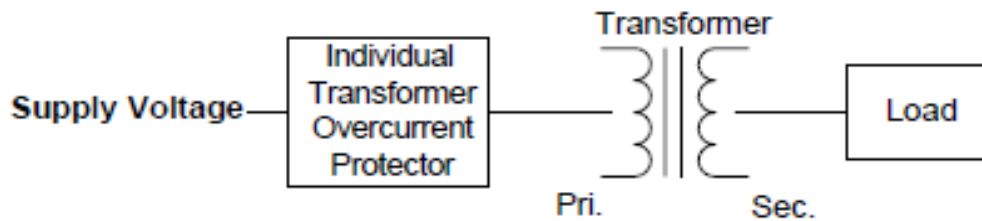

Primary Current	Overcurrent Protection Rating
Less than 2 amps	300% of maximum
2 to 9 amps	167% of maximum
9 amps or more	125% of rated primary current (or next highest standard rating)

Example 2. If the branch circuit feeding the transformer has overcurrent protection to meet the individual protection requirements in Example 1, then individual transformer protection is not required.

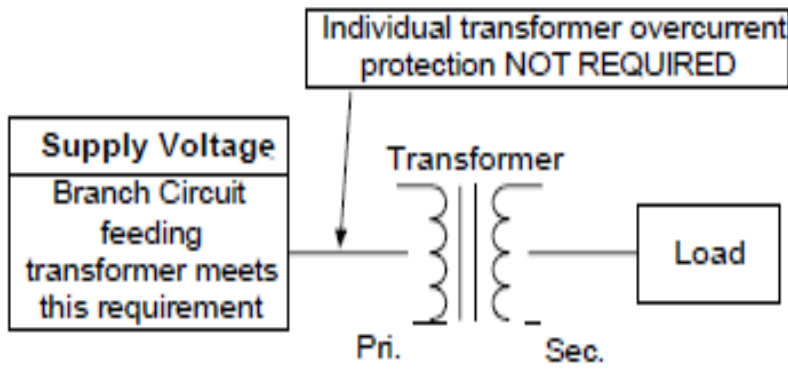

Primary Current	Overcurrent Protection Rating
Less than 2 amps	300% of maximum
2 to 9 amps	167% of maximum
9 amps or more	125% of rated primary current (or next highest standard rating)

Example 3. Primary and secondary protection is required if the transformer has more than two wires on the secondary circuit.

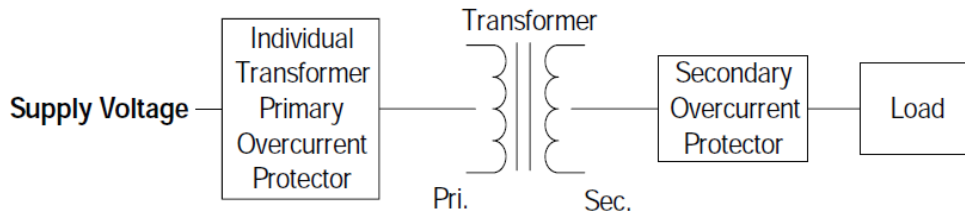

Primary Current	Secondary Current	Overcurrent Protection Rating
250% Primary Current	Less than 9 amps	167 % of maximum
Not more than 250%	9 amps or more	125% of rated primary current (or next highest standard rating)

Example 4. If the branch circuit feeding the transformer has overcurrent protection to meet the individual primary overcurrent protection requirements in Example 3, then individual primary protection is not required. Secondary OCP is required as shown as follows.

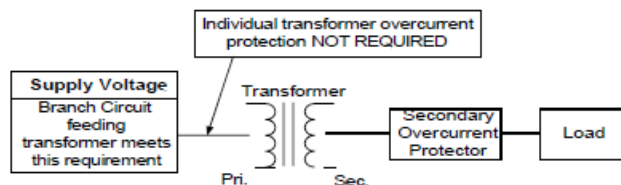

Primary Current	Secondary Current	Overcurrent Protection Rating
250% Primary Current	Less than 9 amps	167 % of maximum
Not more than 250%	9 amps or more	125% of rated primary current (or next highest standard rating)

Specification Guide for Transformers

General

Single and three phase distribution transformers (600 Volt and below)

Provide and install, as referenced on the electrical plans, enclosed dry type transformers as manufactured by Sola/Hevi-Duty or approved equal.

Standards

Transformers must be listed by Underwriters Laboratory, certified with Canadian Standards Association and designed, constructed and rated in accordance with NEMA ST 20 and applicable IEEE & OSHA specifications.

Construction

Cores

All transformer cores shall be constructed of low loss, high quality, electrical grade laminate steel. By design, the flux density is to be kept well below the saturation level to reduce audible sound level and minimize core losses. The core volume shall allow operation at 10% above rated primary voltage at no load without exceeding the temperature rise of the unit.

Coils

- Coil conductors shall be either aluminum or copper and continuous. The entire core and coil assembly shall be impregnated with a thermal setting varnish and cured to reduce hot spots in the coils and seal out moisture. Coils with exposed magnet wire will not be acceptable. Transformers shall have common core construction.
- All transformers shall incorporate a faraday (electrostatic) shield between primary and secondary windings for the attenuation of voltage spikes, line noise and voltage transients.
- Transformers shall be provided with six 2.5% full capacity taps – two above and four below primary rated voltage.
- General purpose transformers are classified as isolation transformers.

Enclosures

- Transformer enclosures shall be constructed of heavy gauge sheet steel and coated with a gray powder paint finish (ANSI 61). Ventilated transformer enclosures shall be UL/NEMA Type 1 rated and UL/NEMA Type 3R rated for outdoor use with the addition of a weather shield. This information must be listed on the transformer nameplate.
- Maximum transformer enclosure temperature must not exceed 650°C rise above a 400°C ambient under full load.
- Transformers must have vibration isolators located between the core and coil assembly and the transformer enclosure to reduce audible sound levels caused from magnetostriction of the transformer core. No externally located vibration dampening pads shall be used as they tend to increase audible noise. Ventilated transformers are to be floor mounted to a concrete pad.
- The transformer enclosure must be grounded by the installer in accordance with the latest edition of the National Electric Code and any local codes or ordinances.

Performance

- Audible sound levels will not exceed limits established in NEMA ST 20:
 - 10 to 50 KVA 45 db
 - 51 to 150 KVA 50 db
 - 151 to 300 KVA 55 db
 - 301 to 500 KVA 60 db
- Transformers, 15 KVA to 500 KVA, shall incorporate a UL recognized 2200C insulation system and exhibit a maximum 1500C temperature rise above a maximum ambient of 400C under full load.

Installation Step 6: Data Acquisition System

The data acquisition computer or DAq is the main computer in the Vertex Edge System.

The Vertex Edge System can be connected to an external Ethernet network at the port shown.



CAUTION

Do not connect an external network to the Vertex Edge Ethernet hub. Use only the external Ethernet connection on the back of the data acquisition computer. Connecting an external network to the hub will impair monitoring capability.





The ferrite is supplied with the unit. It is located behind the display and mounted above the PDU.

NOTE

To maintain EMC certification, the ethernet cable should make 4 loops through the supplied ferrite cable clamp. The clamp should remain on the outside of the Vertex Edge System enclosure.

Start-up

Getting Ready for the Start-up

Honeywell Analytics loads all software on the DAq at the factory. The Universal Chemcassette Analyzers are configured for the mineral acid family of gases. You need to configure each point for the target gases at your facility.

Before you begin the start-up and configuration, gather the following information:

- The location to which each point is connected
- Target gas at each location
- Alarm levels

Ahead of the start-up sequence, make sure that the following installation steps are completed:

- Sample lines connected
- Exhaust line connected
- AC power connection
- Sample Line Dust Filters installed
- I/O Connection

Initial Startup

Use this section to turn on your Vertex Edge System and to configure the analyzer modules for specific gas locations. There are eight parts to this startup procedure:

- Power Up
- Start Program
- Log in the HMI program
- Create a configuration profile
- Replace the Chemcassette Tape
- Leak Checking Sample Lines
- Adjust the Flow rate
- Adjust Supply Vacuum

Start Program

Upon power-up, the DAq automatically starts Linux and loads the Vertex Edge HMI program. After the startup sequence, the Vertex Edge HMI main screen opens as below. The start-up time may take several minutes, and the default user is Viewer.

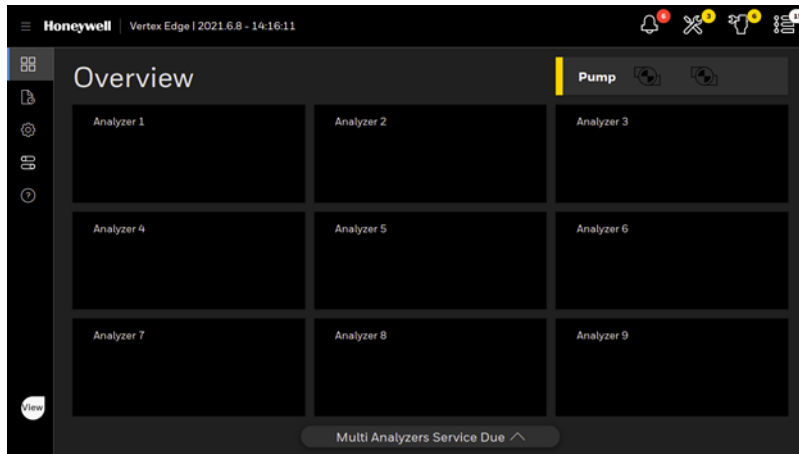

NOTE

Any time the Vertex Edge System is powered up, loss of communications may cause maintenance faults. See Section See "Acknowledge Notifications" on page 84 for more information. for instructions to clear faults.

NOTE

Use the System Manager->Region and time menu to change the time and date on your Vertex Edge System.

Power On

Use the rack power switch behind the touch screen door to power up the Vertex Edge System.

1. Open the touch screen door.
2. Turn on the rack power switch.
3. Turn on the power switch to appropriate analyzers.
4. Close and latch touch screen door. After 15 seconds, the analyzer status LEDs sequence four times through all colors.



1) Main Power ON/OFF Switch, 2) Analyzer Power Switches

After the initial color sequence, the Analyzer LEDs show system status. The following chart matches analyzer status with LED signals.

Mon State	Alarm State	Fault State	time in miliseconds											
			500					400					100	
idle	0	none	black									green		
		maintenance	amber									black		
		instrument	amber					black					black	
	1	any	red									black		
monitoring	0	none	green									black		
		maintenance	amber									green		
		instrument	amber					green					green	
	1	any	red									green		
	2	any	red					green					green	
primary program invalid			amber	black	amber	black	amber	black	amber	black	amber	black	amber	black
unpowered			black											

NOTE

Before the Vertex Edge System can begin monitoring, you must create and install a configuration profile.

Start Program

Start Program

Upon power-up, the DAq automatically starts Linux and loads the Vertex Edge HMI program. After the startup sequence, the Vertex Edge HMI main screen opens as below. The start-up time may take several minutes, and the default user is Viewer.

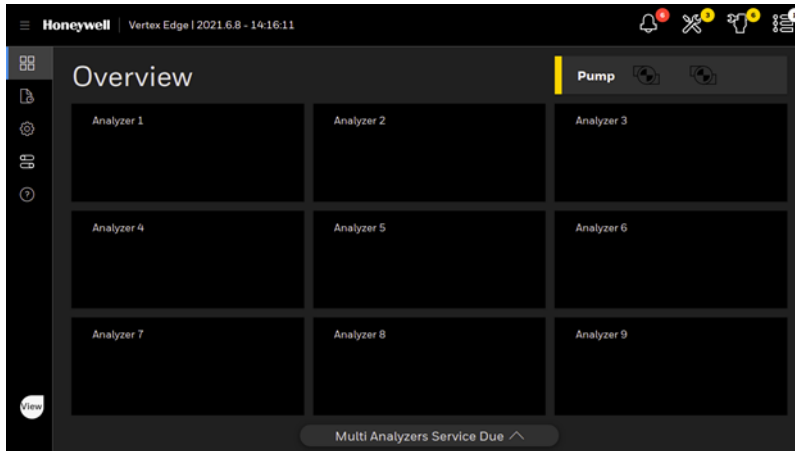

NOTE

Any time the Vertex Edge System is powered up, loss of communications may cause maintenance faults. See Section See "Acknowledge Notifications" on page 84 for more information. for instructions to clear faults.

NOTE

Use the System Manager->Region and time menu to change the time and date on your Vertex Edge System.

Create a Configuration Profile

The configuration profile stores all of the monitor settings in the database on the hard drive. Configuration profiles include system level information, point settings and analyzer information.

1. From the main menu, go to **System Manager > Profile Manager** .

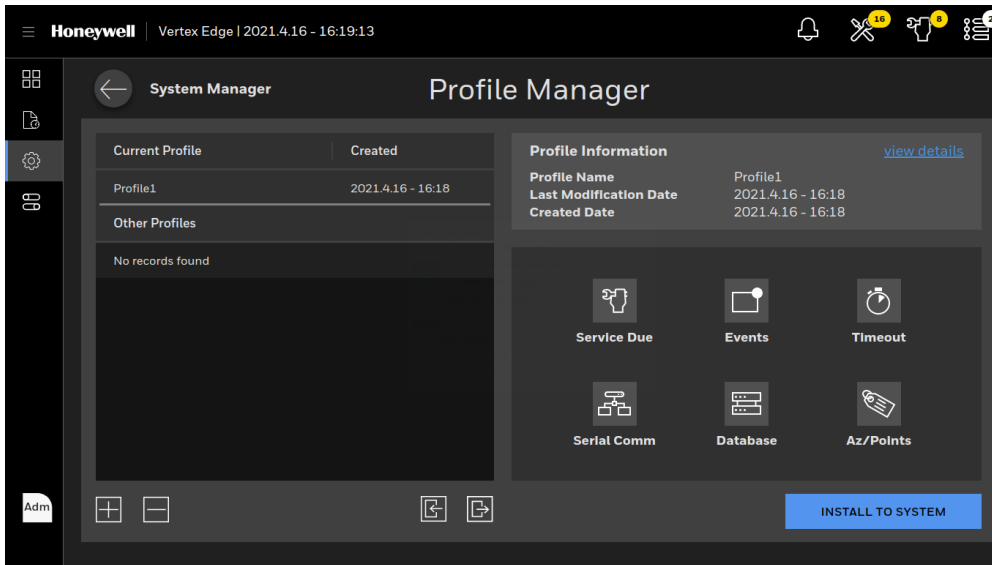

2. Tap the Add profile button .
3. In the Add new profile window, enter a profile name.
4. After entering the profile name, you can set or modify values such as: Notification of service due, Events, Timeout, Serial comm, Database, and Analyzers and points.

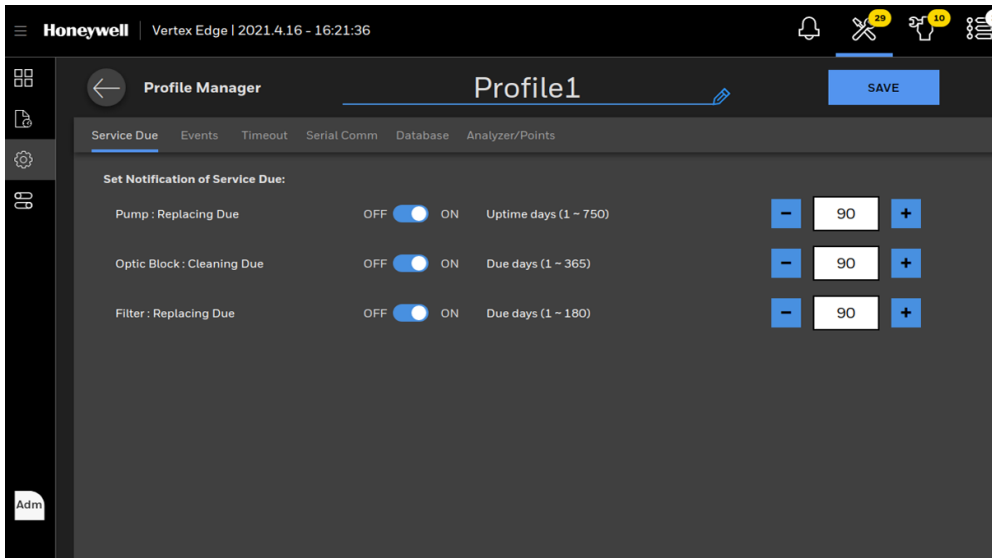

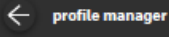
5. After finishing creating the profile, tap **Profile Manager**  or tap **SAVE** to complete the Creating Profile process.
6. Tap **SAVE & INSTALL** whether you want to install this new profile in the system. If you do not want to install this project, tap **SAVE AS** and enter a profile name.

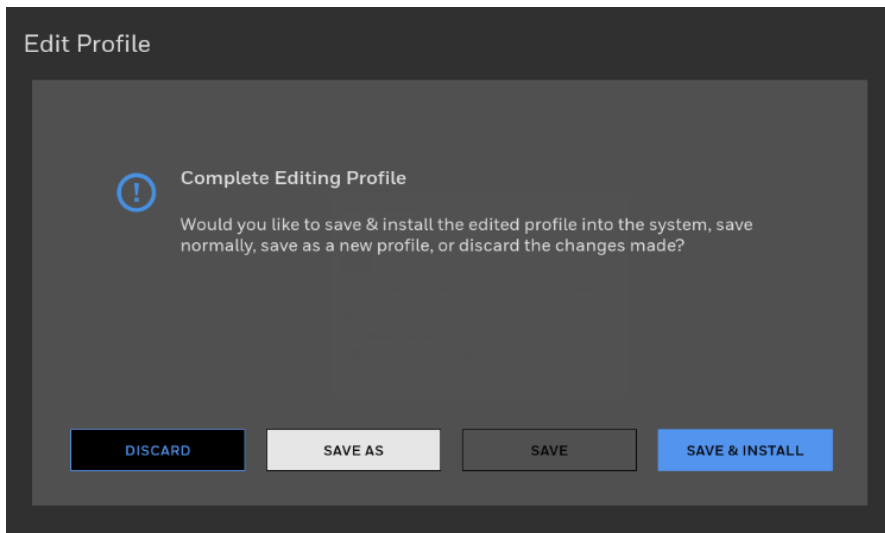

7. Tap **INSTALL TO SYSTEM** to complete installation. Alternatively you can select the profile in the profile list and install it to the Vertex Edge system later.

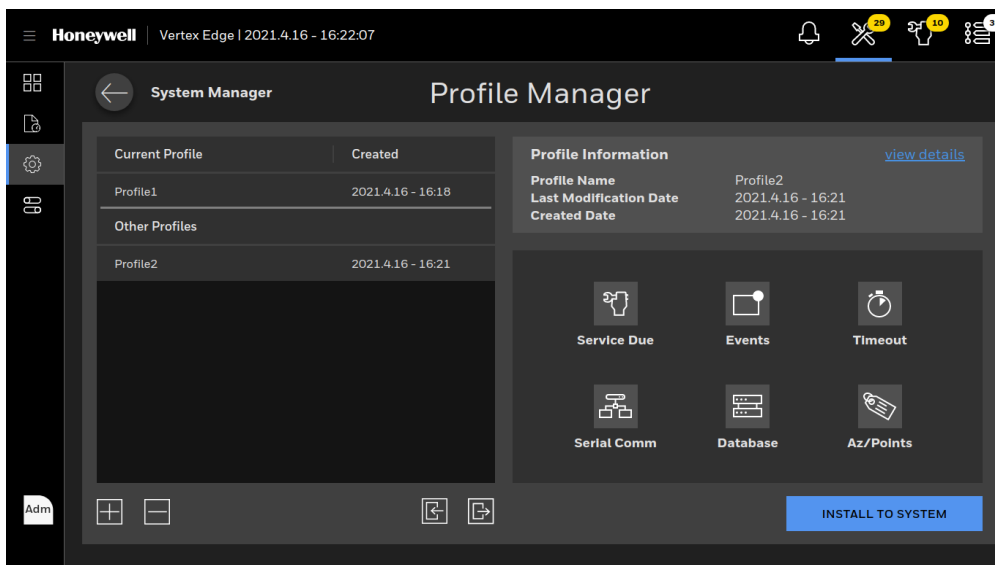

Service Due

Notification of service due is ON, the analyzer will generate a maintenance fault when the maintenance service is overdue. When this option is OFF, an informative event will be recorded instead.

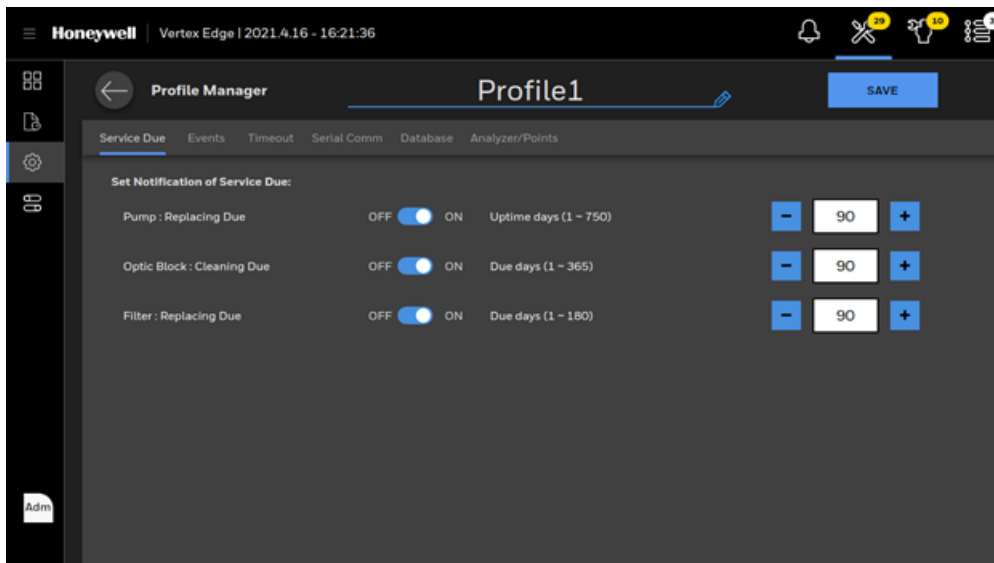

Events

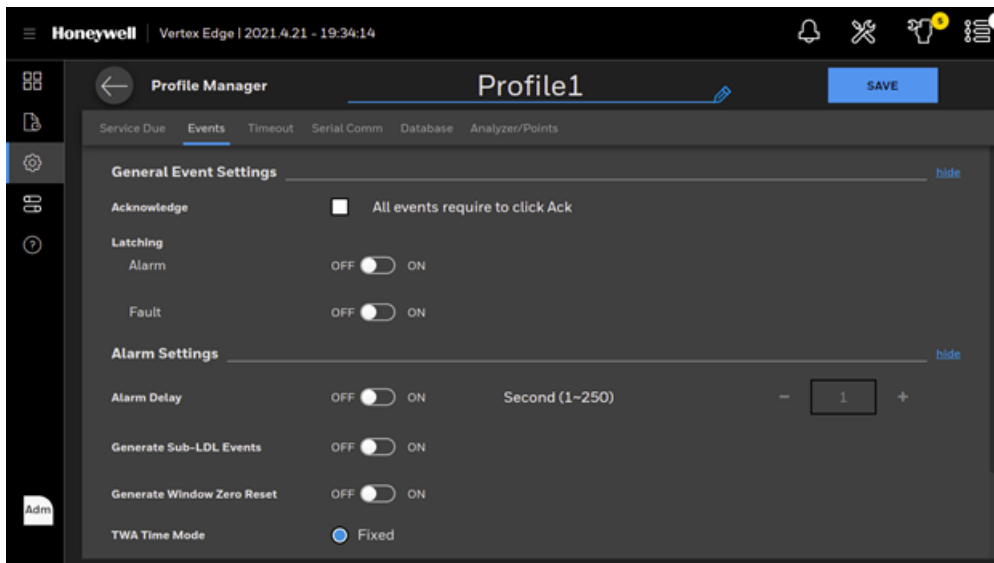

All events require to click Ack

When selected, all gas alarms, and fault events will not be removed from the event list until an authorized user acknowledges the event.

Non-Latching Gas Alarm

A latching gas alarm activates when a gas concentration reaches a level 1 or level 2 alarm setting. The latching gas alarm remains until an authorized operator resets the alarm. Non-

latching gas alarm events clear themselves as soon as the gas concentration drops below the alarm setting.

Non-Latching Fault

A latching fault activates when an analyzer detects faulty conditions. The latching fault remains until an authorized operator resets the fault. Non-latching fault events clear themselves as soon as the faulty conditions disappear.

Alarm Delay

When Alarm delay is ON, a gas alarm will be reported when a gas concentration reaches a level 1 or level 2 alarm setting and stays for more than alarm delay time. If the gas concentration drops below the alarm setting in less than alarm delay time, the gas alarm event will not be reported. This option is to filter out flickering gas events.

Generate Sub-LDL Events

This is to record Optic signal exceed the Sub-LDL limits while gas concentration remains zero as an informative event.

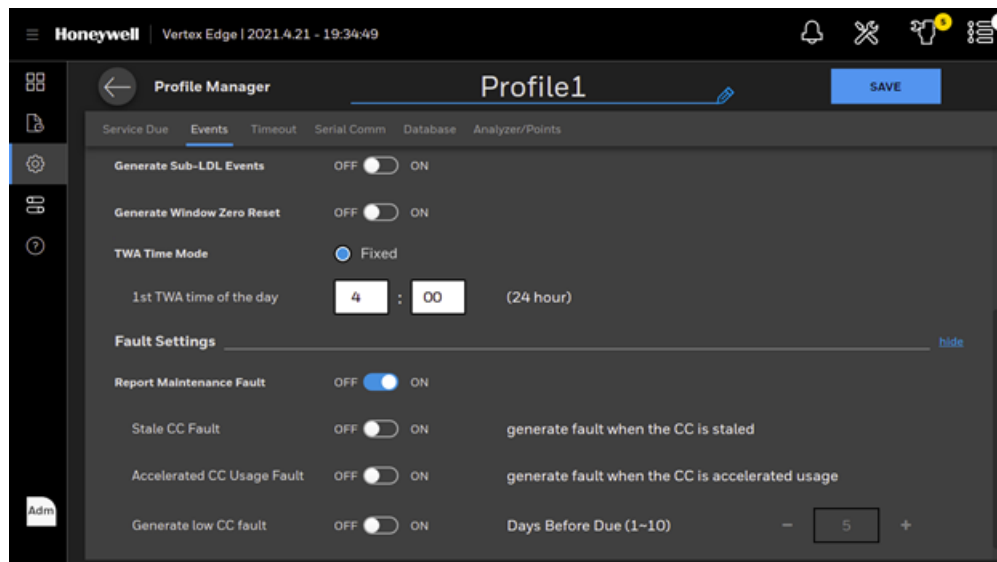

1st TWA Time

Use to set times for the beginning and end of each 8-hour, Time Weighted Average (TWA) period. Use this option to associate the TWA periods with shifts or any other regular event. The system calculates and displays the TWA after each 8-hour TWA cycle.

The default setting is 04:00 indicating that the Vertex Edge will run three successive TWA periods from 04:00 to 11:59, 12:00 to 19:59, 20:00 to 03:59. Remember, the Vertex Edge System uses a 24-hour clock. For example, to set the first TWA to 3:00 P.M., enter 15:00. The system automatically sets the beginning times of the second and third TWA periods at 8-hour intervals from the time entered for the first TWA period.

Report Maintenance Fault

Select OFF to disable maintenance faults. When this option is OFF, the Analyzers will not generate maintenance faults. Instead informative events will be recorded

Stale CC Fault

When this option is ON and Chemcassette is nearing its expiration date, the maintenance fault will be generated.

Accelerated CC Usage Fault

When this option is ON and Chemcassette usage for up to 24 hours exceeds twice of the average daily usage, the maintenance fault will be generated.

Generate low CC fault

Vertex Edge software tracks the amount of Chemcassette® tape remaining on the supply reel and triggers a low tape event when remaining tape is less than Days Before Due. Choosing OFF disables the low tape event.

Set Timeout Values

Authorized users may temporarily disable points or inhibits alarms from activating and points from monitoring. A point or alarm that is disabled/inhibited longer than the timeout limit will cause a maintenance fault which will call attention to locations excluded from monitoring.

Select On and enter a timeout up to displayed minutes or select OFF to disable the maintenance fault.

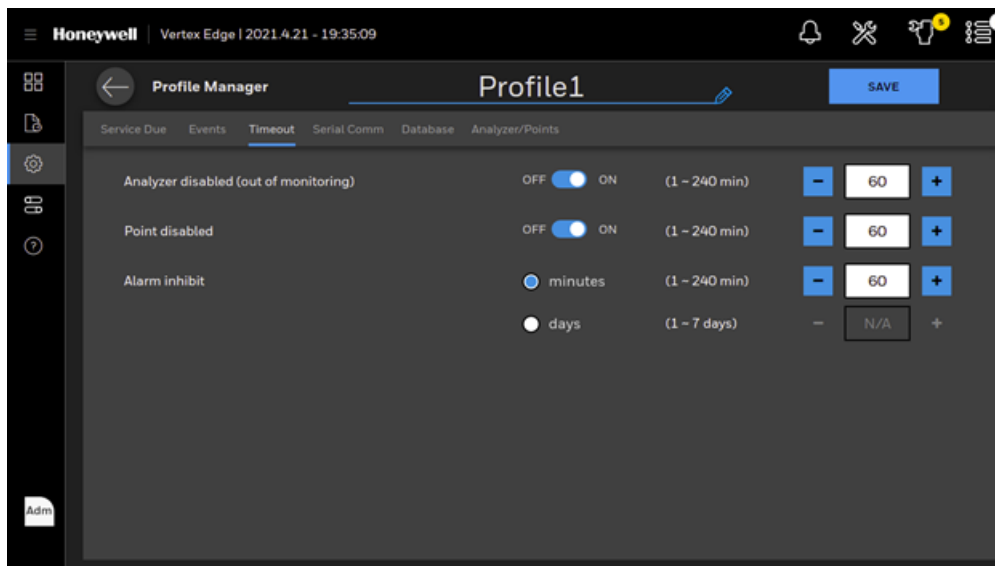

Analyzer/Points

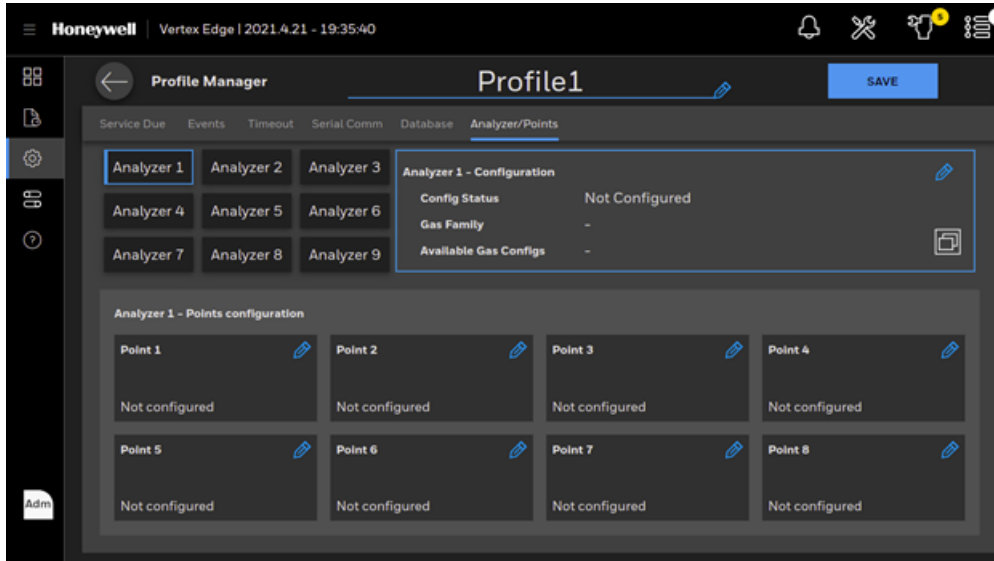

Duty Cycle

This function allows the user to extend the duration of the tape advance interval. This is useful in applications in which a background level of gas is expected in normal operation. This interval can be configured for up to fifteen minutes. When in monitor mode, if the detector reaches its maximum concentration for that window, it will not advance tape and stays at current window until the duty cycle expires.

Power-up mode:

There are three options in power-up mode as below.

- Power up in monitoring mode: Analyzer will start monitoring mode after it powers up.
- Power up out of monitoring mode (default): Analyzer will stay at idle more after it powers up. An operator manually starts monitoring mode.
- Power up in last state: Analyzer remembers its last state and gets back to that state after it powers up.

Select the analyzer to configure and tap on the EDIT  button.

Activate the selected analyzer and select the gas family. If you want to apply same configurations to all analyzers, tap on the APPLY TO ALL button.

NOTE

When making and saving a change to an item in the analyzer configuration, this also changes all items in the points to the default.

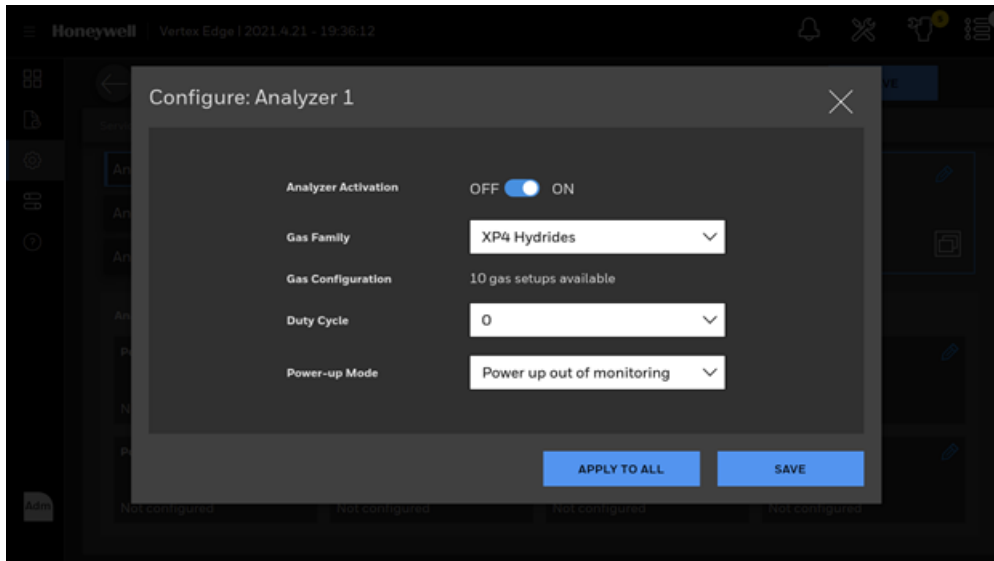

Units

Select to display concentrations in milligrams per cubic meter. If this option is not selected, Vertex Edge displays concentrations in parts-per-million (ppm) or parts-per-billion (ppb).

Select a target gas for the point and enter the gas location of the place where gas is sampled.

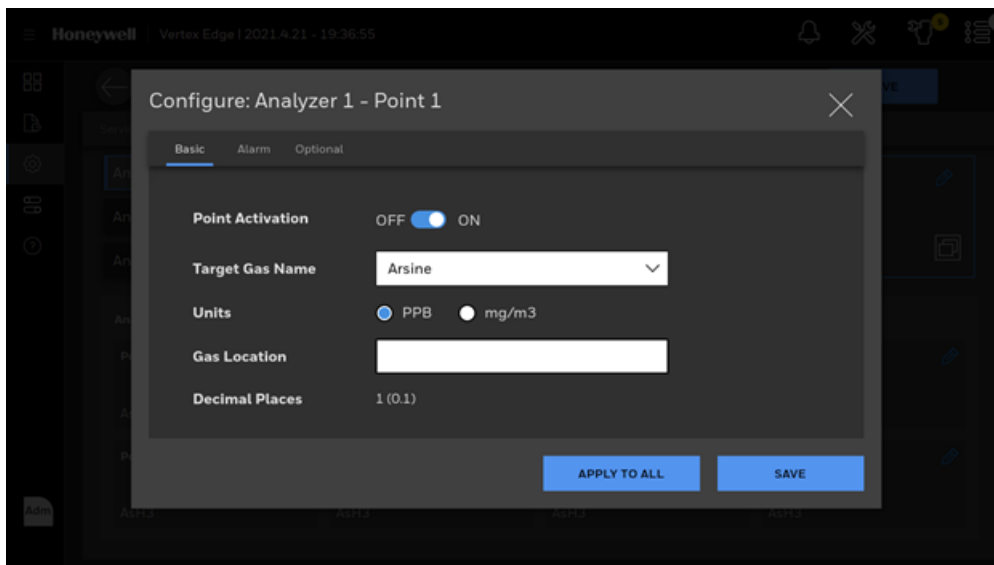

Alarm levels can be selected from the preset or entered. When custom is selected, alarm levels are edited manually.

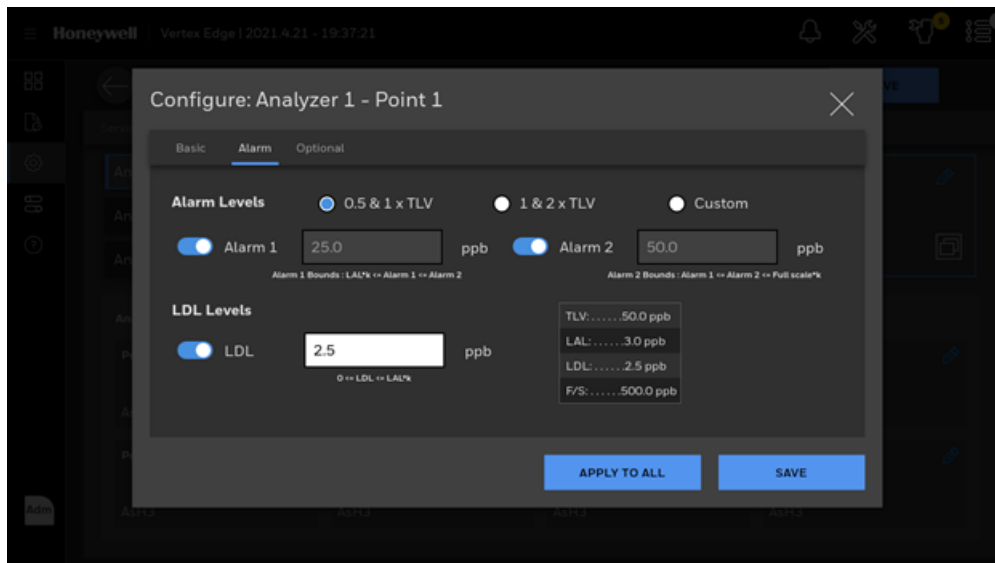

K-factor

K-factor is a feature that allows gases' cross-sensitivity to be employed to measure a different gas using gas calibrations of a selected gas. The detector's readings are modified by the known relationship between the two gases. For example, a 5ppm concentration of Gas A is seen by the detector as the same as a 5.8 ppm concentration of Gas B. The K-factor is 1.2 ($5.8 \div 5 = 1.16 = 1.2$ when rounded to one decimal place).

When k-factor is enabled, gas levels will be multiplied by k-factor automatically. Alarm levels should be checked again after enabling the k-factor.

NOTE

When mg/m³ is selected as a measurement unit, k-factor is not allowed to be ON.

Non-Zero Warning

When this option is ON and non-zero gas concentration is detected, an informative event will be recorded and non-zero warning status will be reported to DAq. The point with non-zero warning will blink in green.

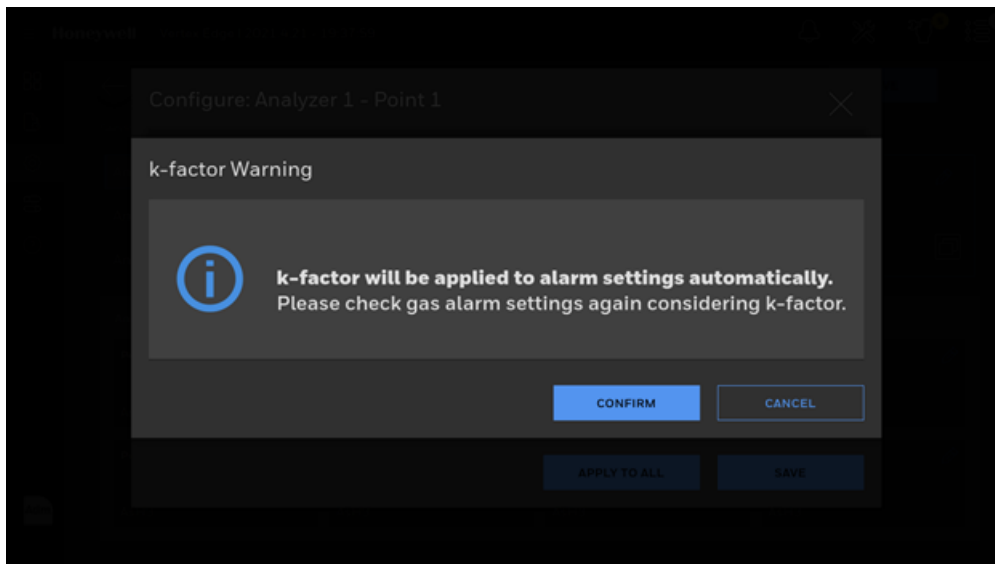
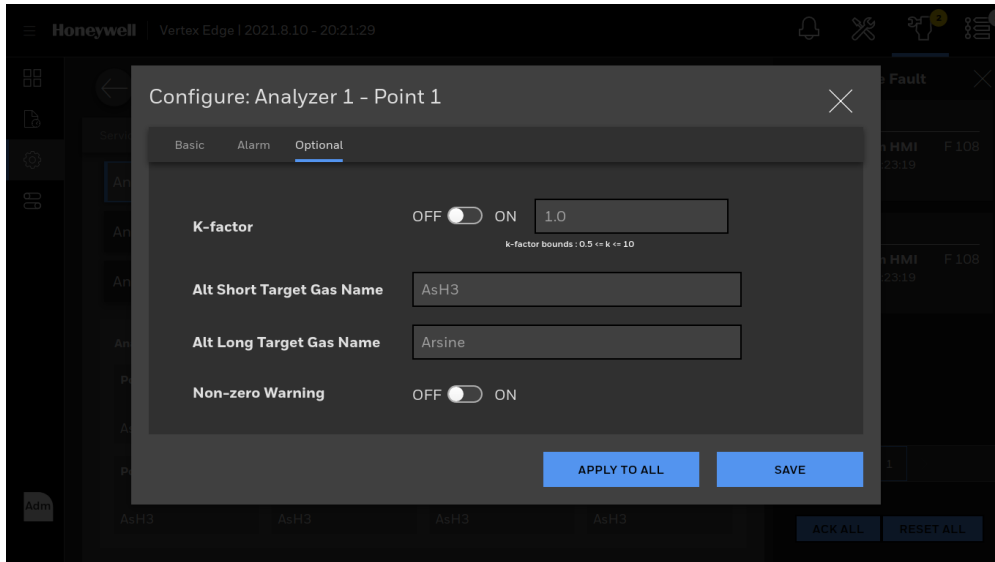
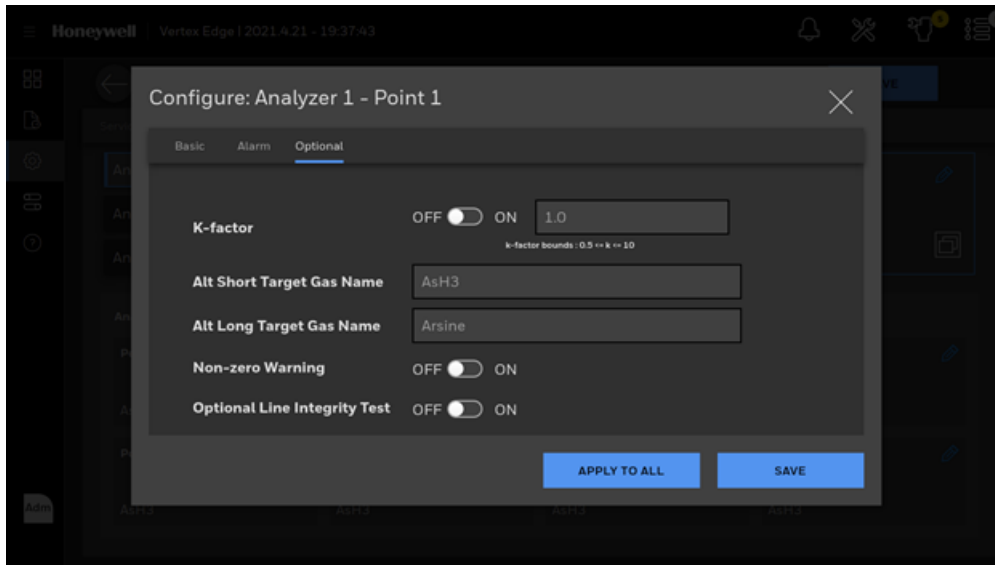

Copy Analyzer/Point Configurations

When multiple analyzers are configured in same way, an operator can configure one analyzer and copy it to other analyzers to save time.

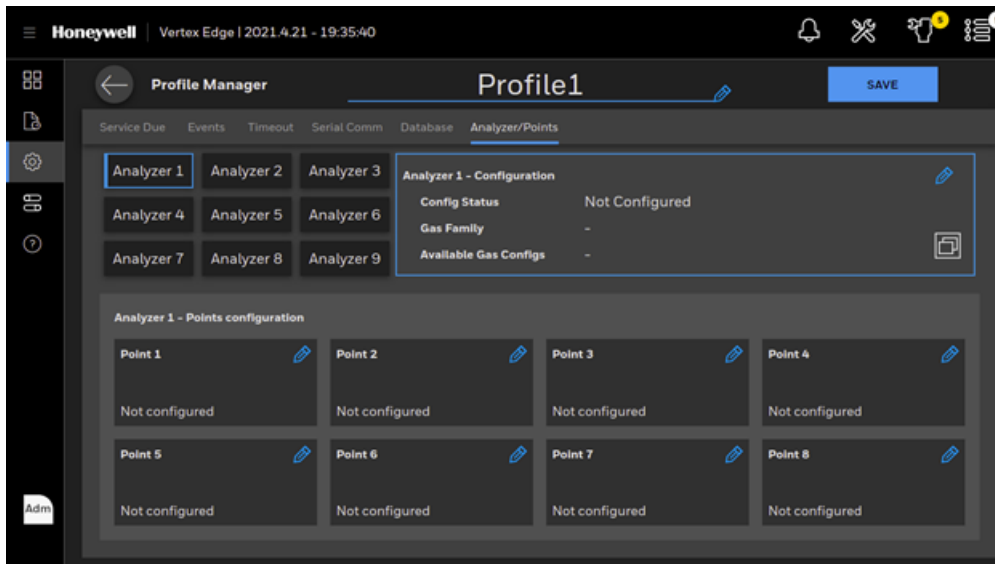

To copy analyzer/point settings from one analyzer to other analyzers, tap on the COPY  button. Select the source analyzer in the analyzer list and check the analyzers where same configurations are applied.

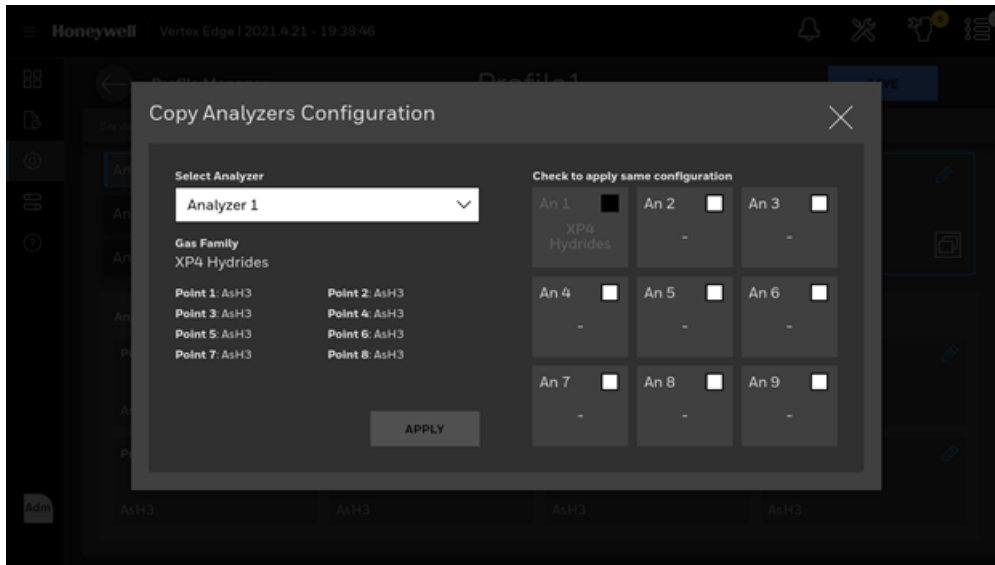

Export/Import a Profile

To export a profile, plug in USB flash drive in the DAq. Select the profile in the list and tap EXPORT to export it to USB flash drive

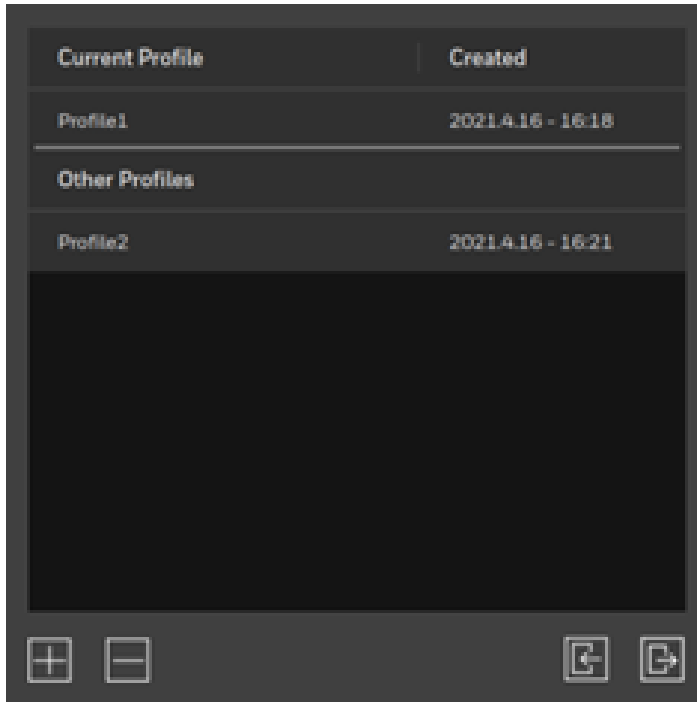

Enter a profile name and select the location where the profile will be exported

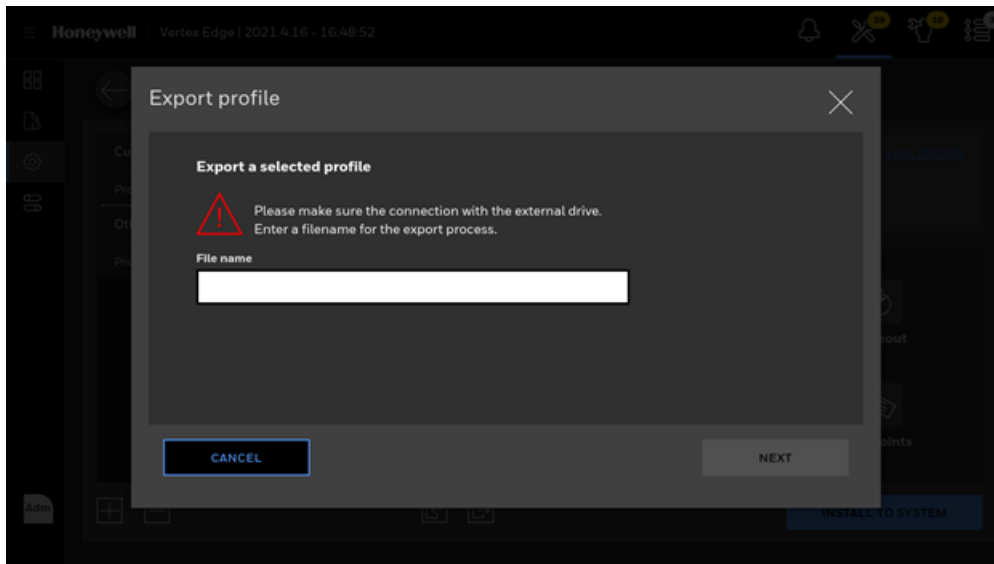

After selecting the location, tap NEXT and profile exporting will be complete.

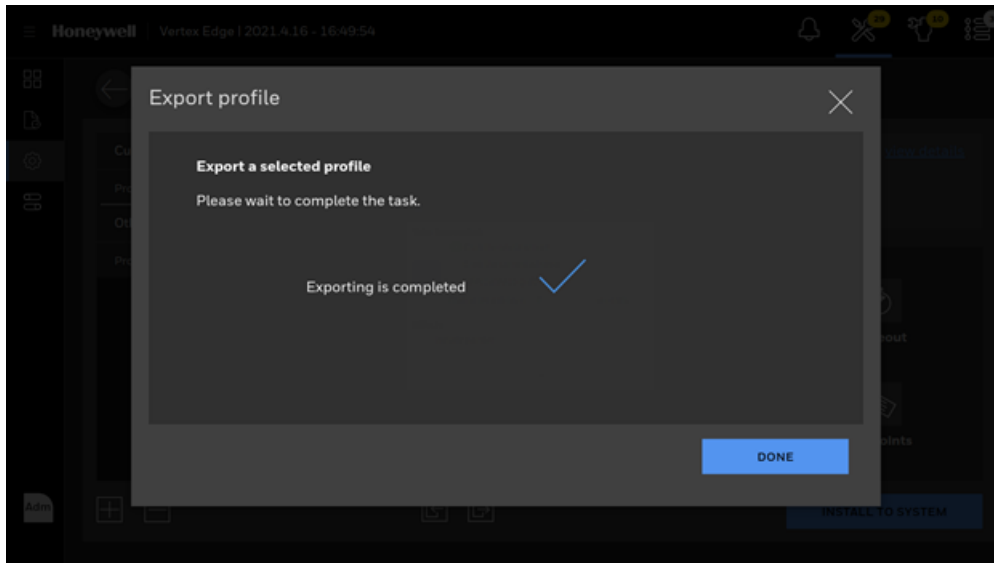

To import a profile from USB flash drive, tap **IMPORT** 

Select the profile in the Import Profile window and tap **NEXT**.

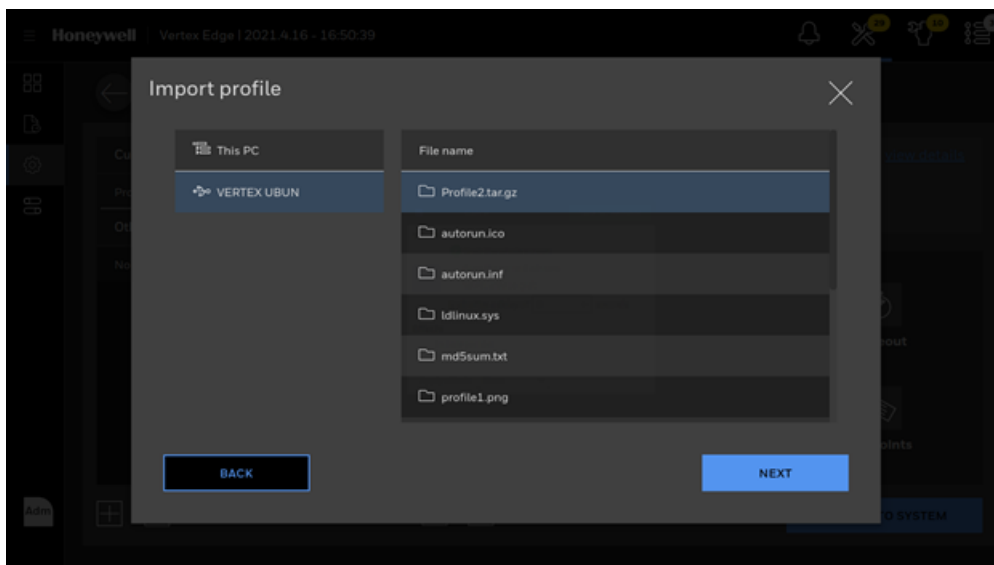

Selected profile will be imported and shown in the profile list of Profile Manager

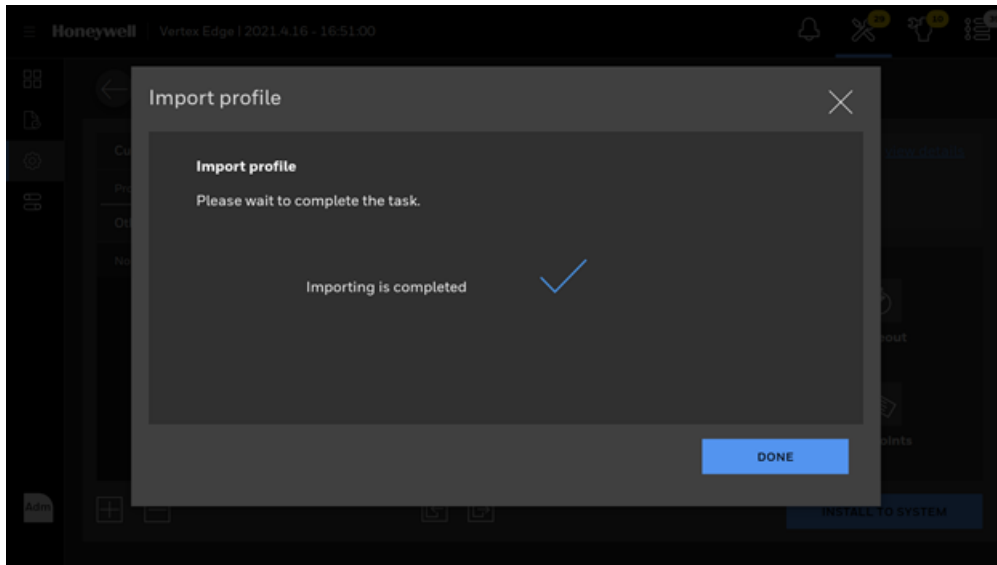

Login and Logout

To protect the integrity of the system, the Vertex Edge System classifies the access levels as a viewer, an operator and an administrator. If you require access to a protected menu, you must log in under a user role with permission to use that menu. The Vertex Edge System administrator assigns a role to the user accounts. The role of the currently logged user is shown on the bottom of the main menu.

1. To log in, tap on the user role icon at the bottom of the main menu and select Log In.

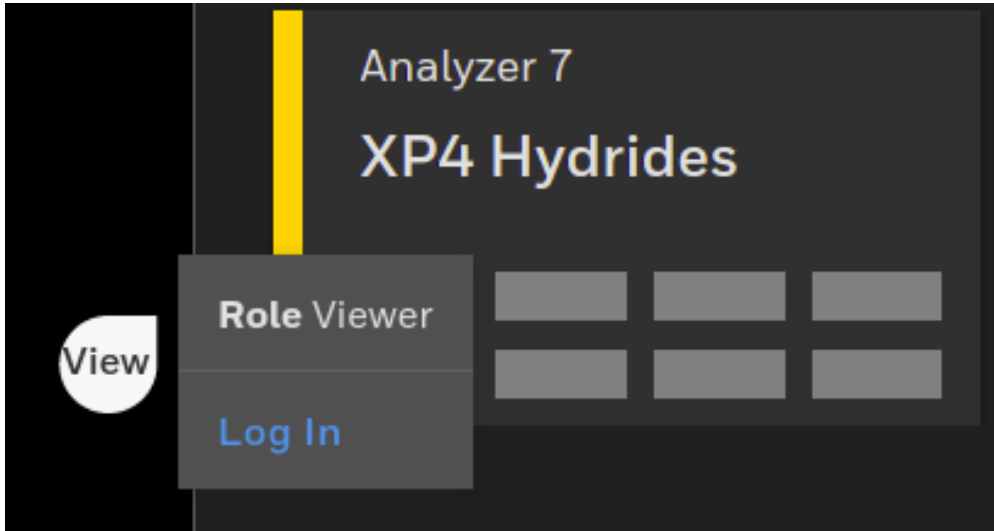

2. Enter your user ID and password in Log In screen and tap on the Log In button.

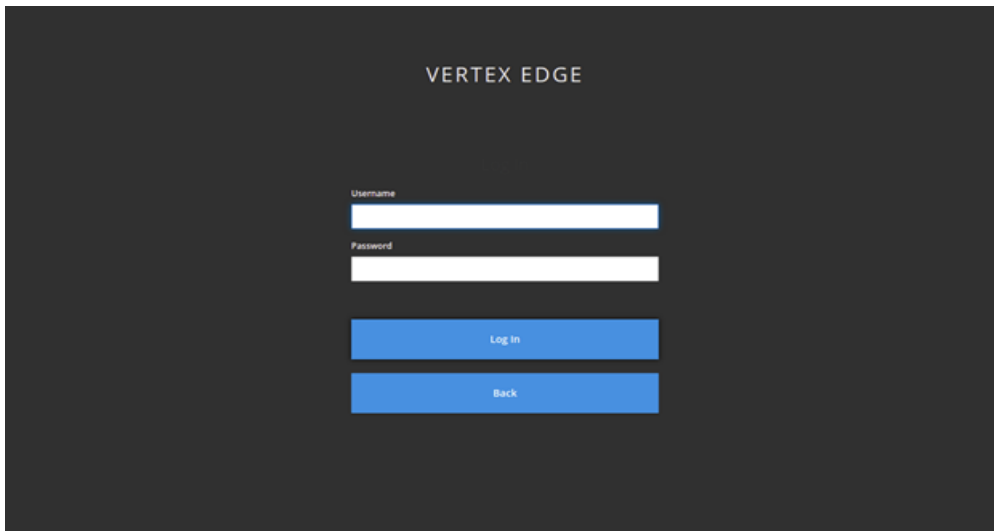

3. Once logged in, the system checks your role. As you use Vertex Edge menus, only the pages to which you have access will be accessed. The pages associated with functions to which you are denied access will request you to switch to another user with an appropriate authority.

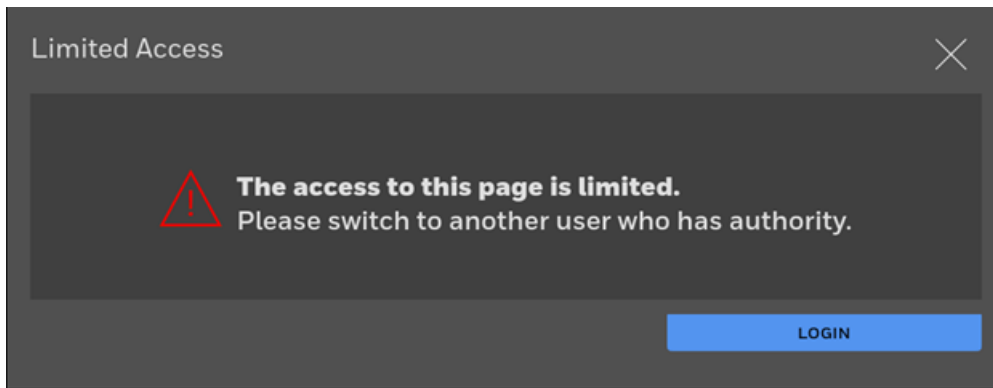

4. To log out tap on the user role icon at the bottom of the main menu and select Log Out.

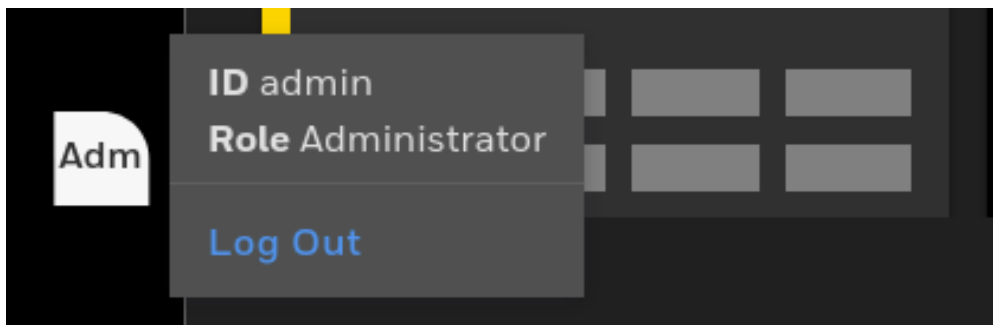

NOTE

Default user ID and password are Admin / Admin for an administrator role and Operator / Operator for an operator role.

NOTE

Upon initial installation and login, it is strongly recommended to change the password of the default users in accordance with the password complexity.

Create a New User

Administrator can add a new user and assign an appropriate role to the user account.

1. From the main menu, go to System Manager > Security
2. To add a new user, tap on the ADD button 
3. Type a username, password according to the password complexity and select an appropriate role to the user.

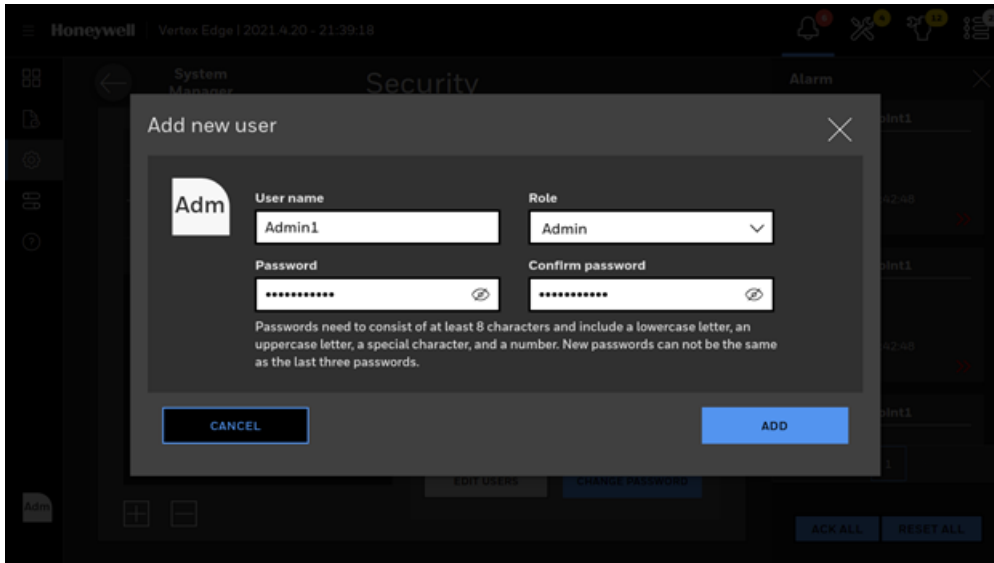

NOTE

Passwords need to consist of at least 8 characters and include a lowercase, an uppercase and a special character and a number.

Install the Chemcassette

Change the Vertex Edge Chemcassette tape for any of the following reasons:

- Scheduled end-of-tape service
- Low Chemcassette warning
- Chemcassette has expired
- End of Chemcassette

1. In the left navigation panel, tap **OVERVIEW** 
2. Tap on the selected Analyzer.
3. In the Components status bar,



tap on the Chemcassette button .

4. In the Chemcassette window, tap **REPLACE CC**.

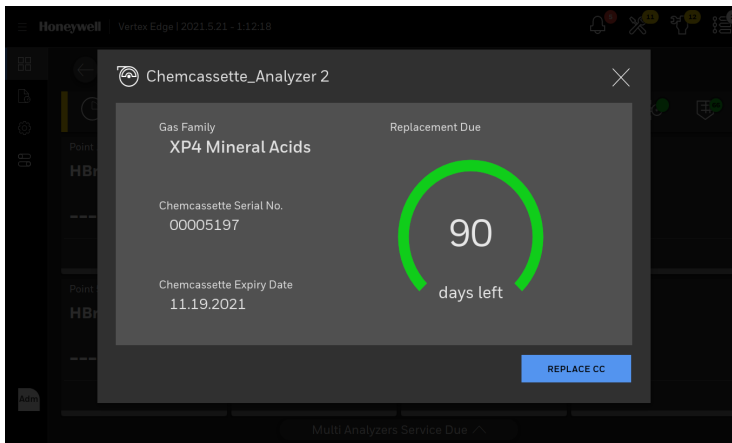

5. “Stopping monitoring mode” confirmation screen pops up. Tap **CONFIRM**.

6. The tape replacement procedure gets started. The Analyzer is released, and the Optics gate opens.

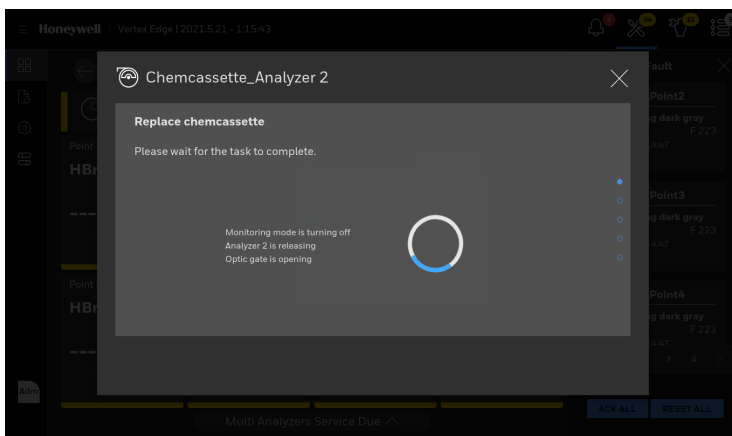

7. Pull out the Analyzer and remove old Chemcassette tape.

8. Route the Chemcassette tape through Optics blocks and guide rollers.

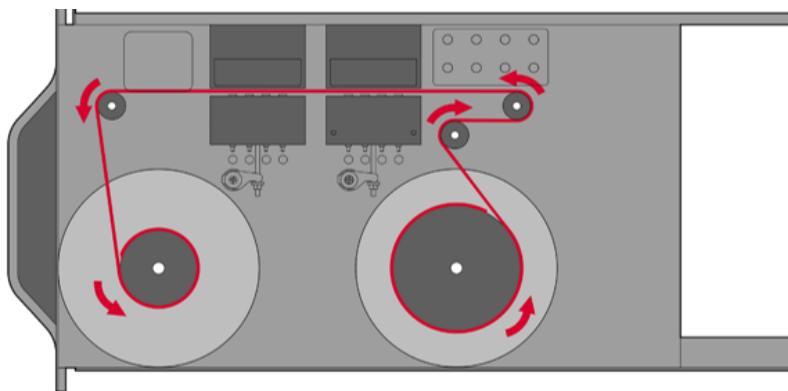

9. Install leader tape into slot of the pick up reel.

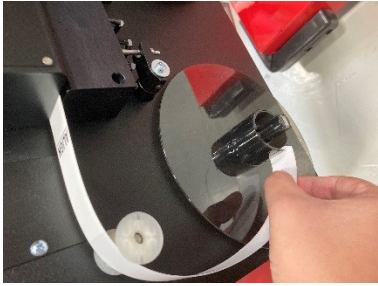

10. When the Chemcassette leader is installed, adjust the leader tape by verifying the 'Align' mark on the leader tape is visible on either side of the optic blocks (as seen in the picture below. The HMI screen also shows the leader tape configuration). The alignment is essential to adjust and verify the Optics module before gas monitoring.

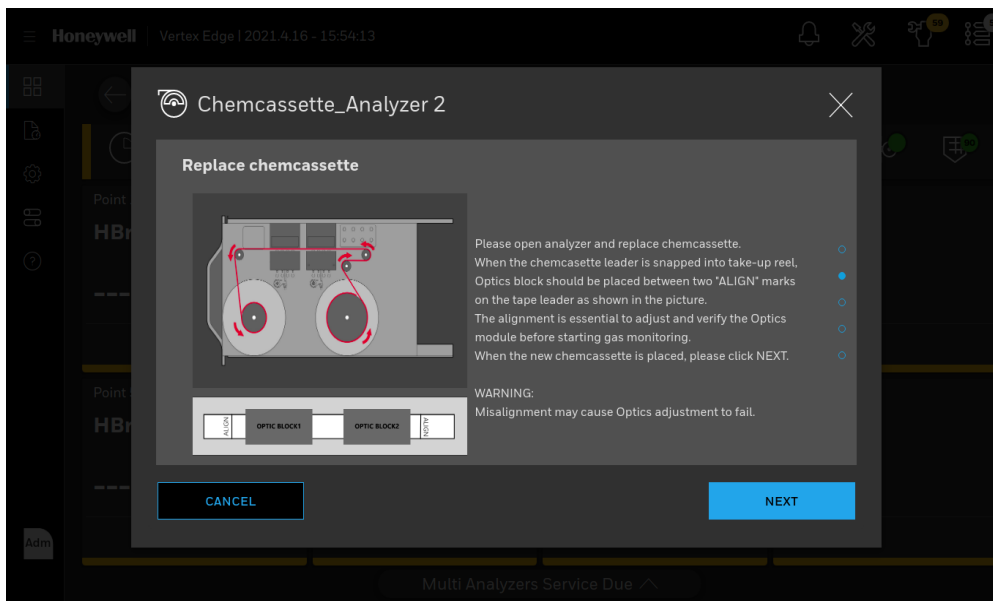
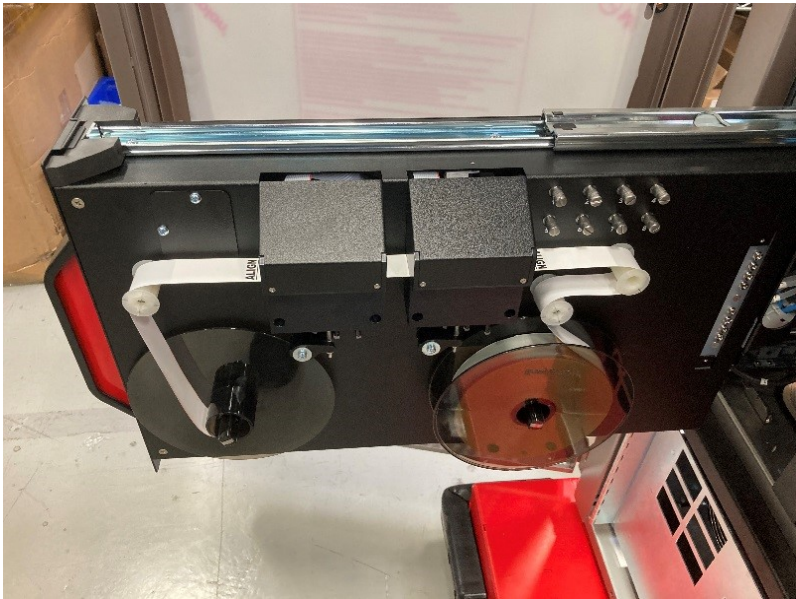

11. When new Chemcassette is installed correctly, tap NEXT.

12. The Analyzer reads the RFID tag on the Chemcassette tape and shows the tape information. Check the Chemcassette information and Tap **NEXT**.

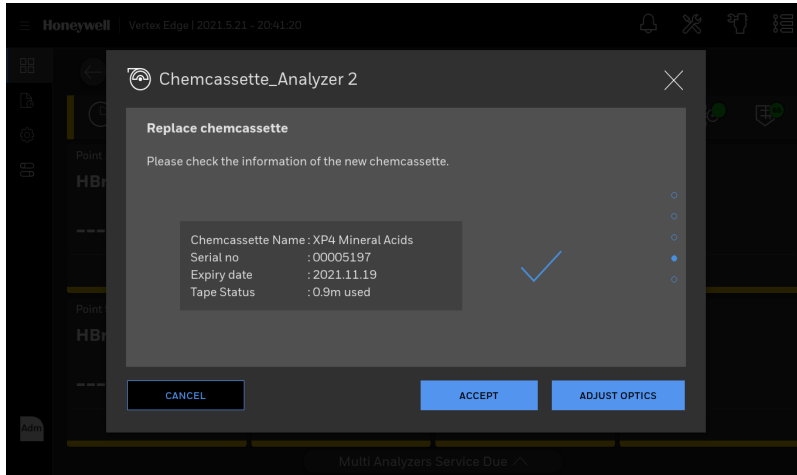

13. If the Chemcassette is not a brand-new tape, the user can accept the Chemcassette tape or adjust Optics. If Accept button is pressed, it will accept the Chemcassette and update the tape information without optics adjustment. If tape is not new out of the bag, a leader tape can be used to run the Optics Adjust by pressing Adjust Optics. The leader tape will need to come from a fully used tape. Do not rewind the CC to reuse the leader tape. If using the leader tape, the user will need to manually install the leader tape for each color to be tested.

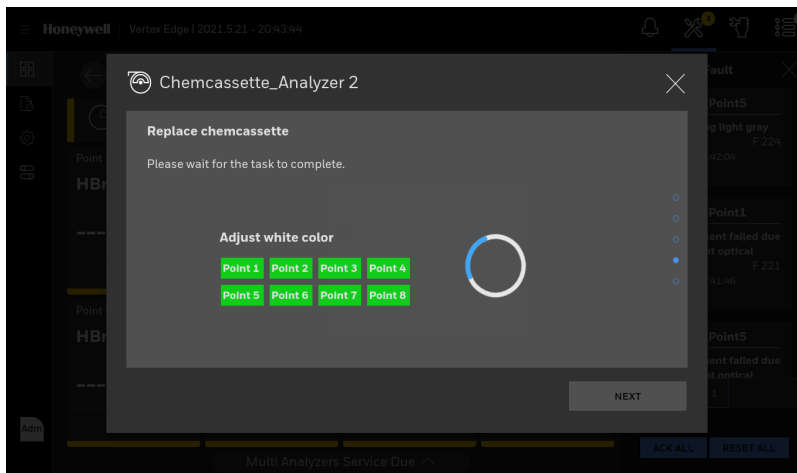

14. After completing the Optics adjustment/Verification, Tap **NEXT**
15. In the **Start Monitoring Mode** window, tap **START** if you want to start the monitoring mode. If not, Tap **IDLE**. The new Chemcassette information is displayed.

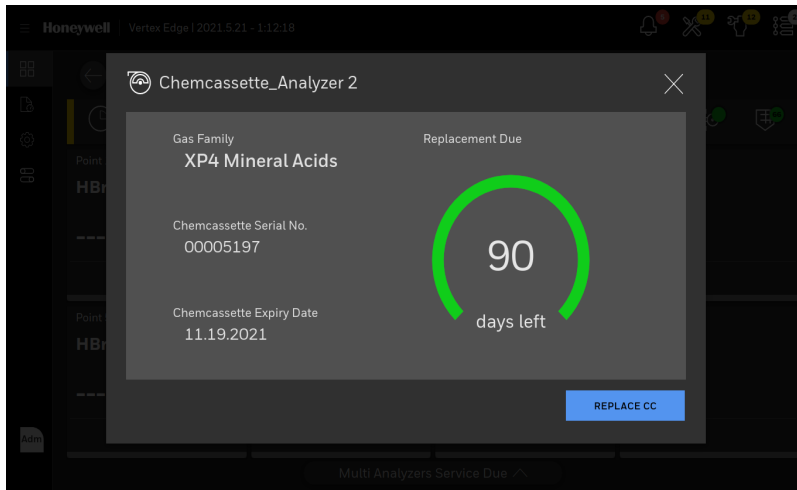

Adjust Supply Vacuum

After all analyzers have been configured, Chemcassettes® loaded, a leak check has been performed, and all tubes are connected, proceed to adjust supply vacuum in the Flow Rate screen as follows.

1. If there are any empty analyzer slots, the exhaust ports should be blocked using the plug prior to adjusting the supply vacuum. (Plug P/N: 0235-1318)



2. In the left navigation panel, tap OVERVIEW 
3. Tap on the selected analyzer.
4. In the Components status bar,



tap on the

Flow Rate button 

Flow Adjust Screen



5. In the Flow Adjust screen, press Adjust flow. This will turn the flow on for that analyzer.
6. A message will appear to confirm that the unit will not be in monitor mode. Press 'Confirm'
7. Continue through all analyzers populated in the system and Press "Adjust Flow" so that flow is turned on for all of the analyzers in the system.
8. Once all analyzer flow is 'on', press Vacuum Levels (as shown below).



View of Vacuum Level Screen

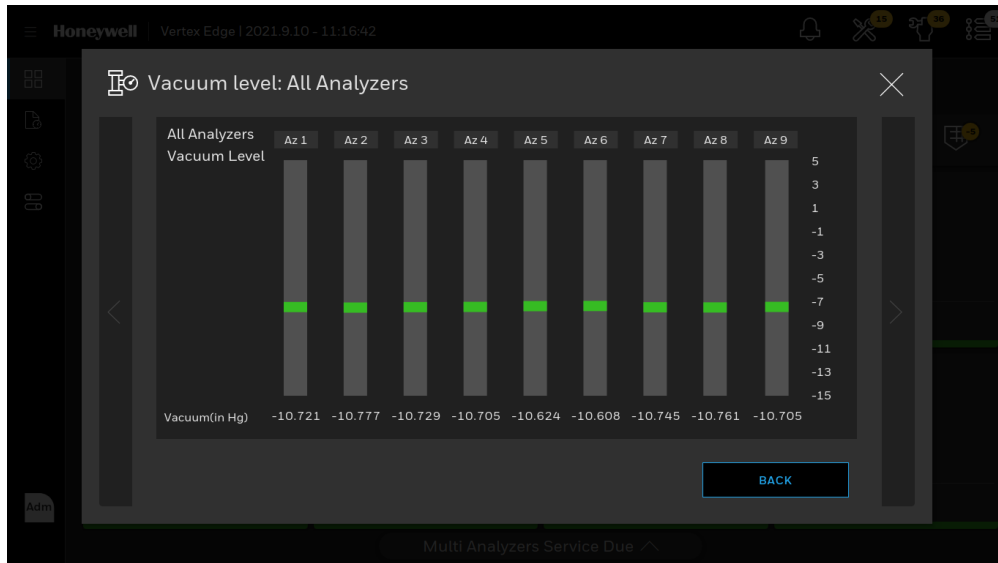

- Check the vacuum levels for all connected analyzers. If needed, adjust the vacuum level to a range of 11 to 13inHG (minimum required is 10inHG). The vacuum level is changed by using the Supply Vacuum Adjust valve as shown below. All analyzers will adjust as the supply vacuum adjust valve is turned.

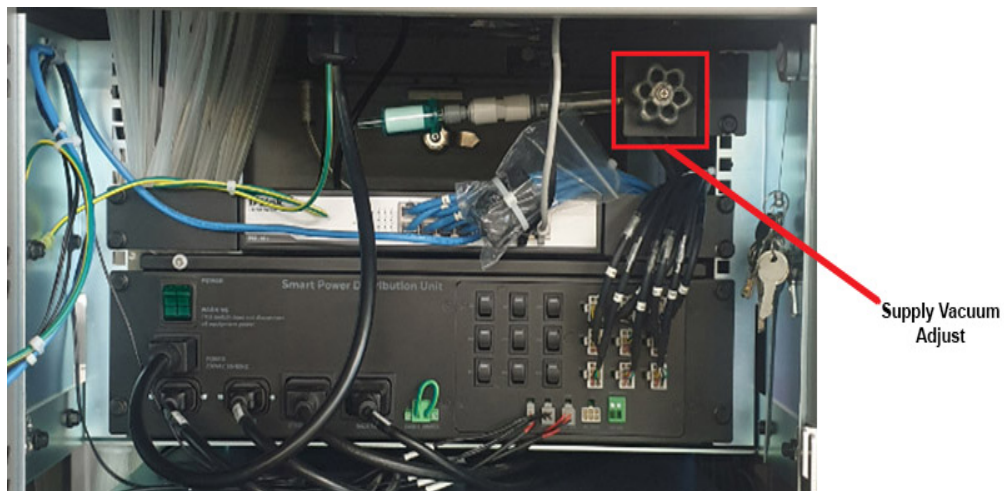

- Once complete, leave the flow on for all analyzers and move onto the Adjust Flow Rate section.

NOTE
 At higher altitudes with many analyzers installed, and/or a system on a 50Hz mains, the system vacuum may not be able to achieve 11inHg. In this case, the maximum achievable sample point flow rate shown may be reduced by up to 20%..



Supply vacuum should be readjusted whenever analyzer(s) are installed to or removed from the rack.

Adjust the Flow Rate

With the system vacuum level set, the unit is now ready to adjust flow for all the points.

1. If still in the Vacuum level screen, press back.

If not, enter the Adjust flow screen as described in steps 1-4 in the Adjust Supply Vacuum section.

2. Check the flow rate, and if there are any points marked in yellow, the point must be adjusted. See below as an example.

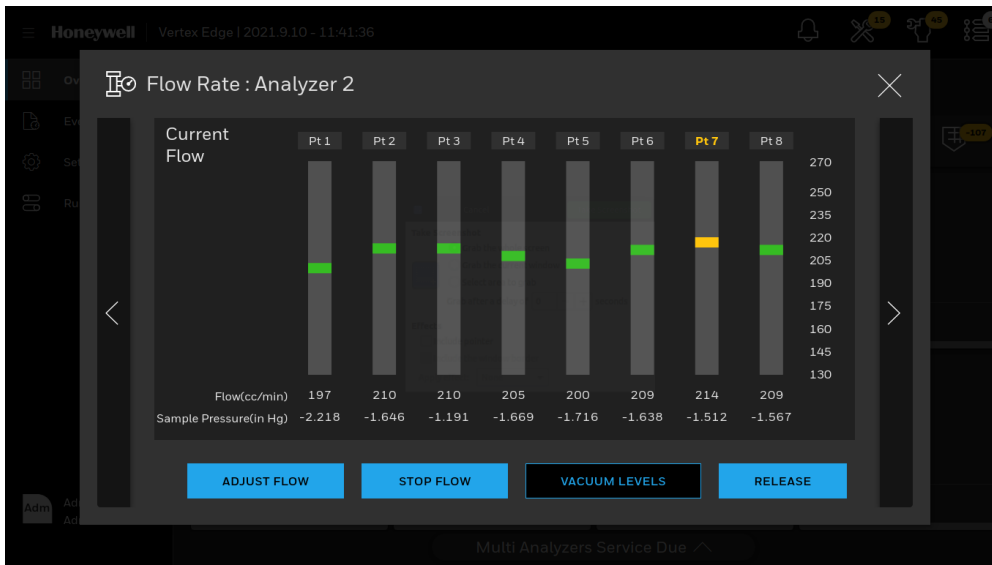

3. Tap **RELEASE** to access to the needle valve on the side of the Analyzer if it is locked to access the needle valves.
4. Turn the needle valve for the point that is to be adjusted until the flow reaches the target flow rate of 200 ± 10 cc/min. Once the flow is in this range, the bar will change color to green.
5. Repeat for all points in the analyzer that are out of range.
6. Repeat for all analyzers until the entire system is complete.
7. Once complete, press **STOP FLOW** for each analyzer. This will stop for the flow for each analyzer.
8. Once all analyzers have the flow stopped, the pump will turn off.

Leak Checking Sample Lines

Perform a leak check of the sample lines following installation and also whenever a line is changed or moved. The leak check procedure involves plugging the end of the sample line and verifying that there is no flow through the line. To perform a leak check:

1. Put the affected Analyzer in idle mode.
2. Go to Overview and select the Analyzer.

3. Select Analyzer and open Flow Rate screen.
4. Tap on the Start Flow button.
5. Securely plug the end of the sample line being tested.
6. Verify that the sample flow is less than 20cc, and that the Sample Pressure equals the Supply Vacuum within a tolerance of +/-0.5 inHg.
7. After testing all points on the selected analyzer, tap on the Stop Flow button.

NOTE

Tap on the Start Flow button on Flow Rate screen even if the pump is operating. Tapping on Start Flow turns on the solenoid valve to provide vacuum to the analyzer.

A sample point failing to meet both the flow and vacuum conditions of step 6 indicates either a leak in the sample line or a faulty sample inlet connection.

To troubleshoot the condition, disconnect the sample line at the inlet port at the top of the Vertex Edge cabinet. Securely plug the inlet port and repeat the above leak check procedure.

If the sample point passes the test with the top port plugged, the leak is somewhere in the sample line and the line must be replaced. If the sample point fails the leak check procedure with the top inlet port plugged, contact Honeywell Analytics for assistance.

CHAPTER

4

Device Operations

Edit User Accounts

Administrator can edit user counts and change the user role and password.

1. From the main menu, go to System Manager > Security
2. To edit users, select the target user in the list and tap on the EDIT USERS button.
3. User role and password for the user can be changed by an administrator.

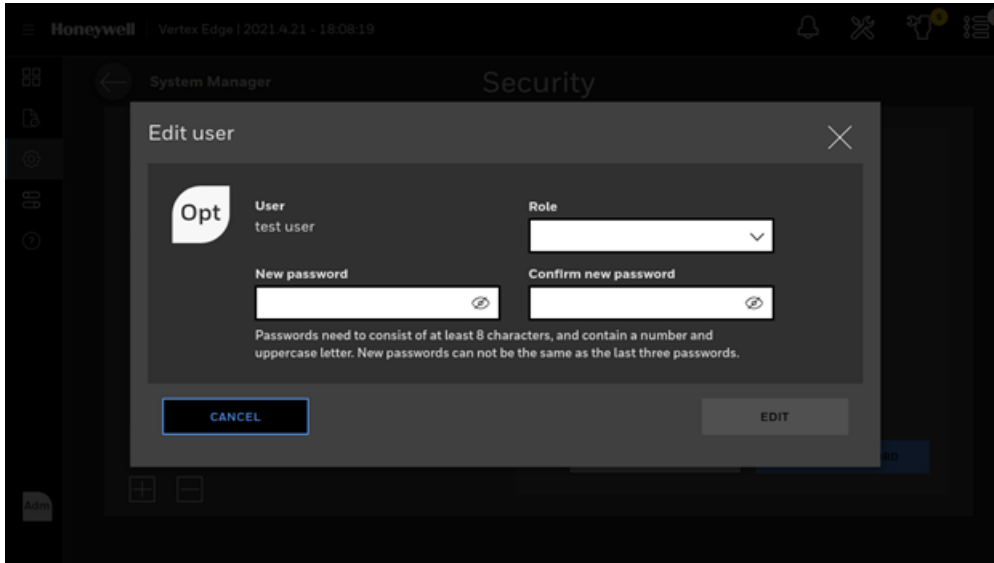

4. Alternatively, logged user can change one's password by tapping on the CHANGE PASSWORD button.

View Overview Status

View Overview status of all connected analyzers such as analyzer status, pump status and point status of up to 72 points

1. In the left navigation panel, tap OVERVIEW 
2. Analyzer status is shown with gas family configured to the Analyzer

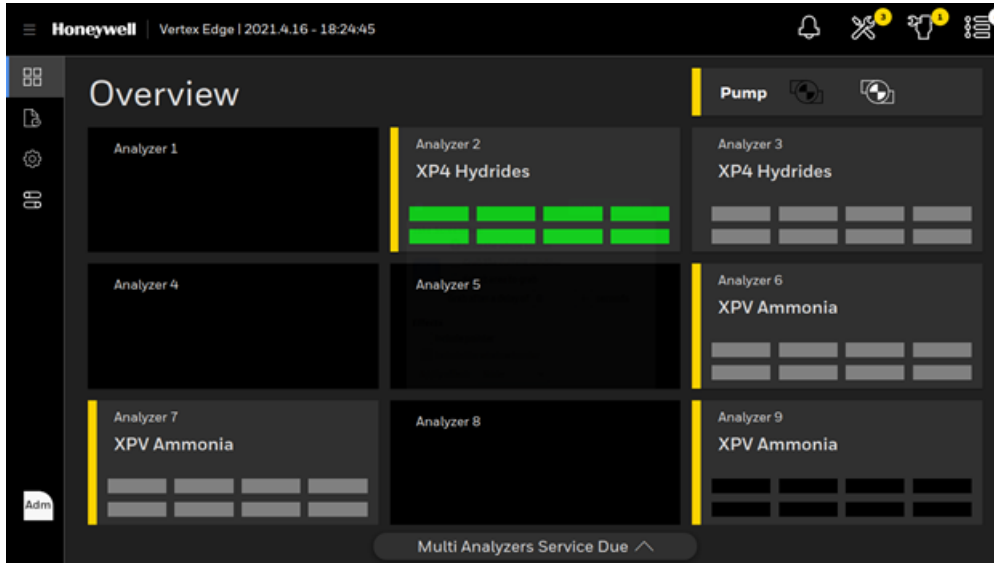

The analyzer status and point status are represented graphically as below depending on the status and configuration.

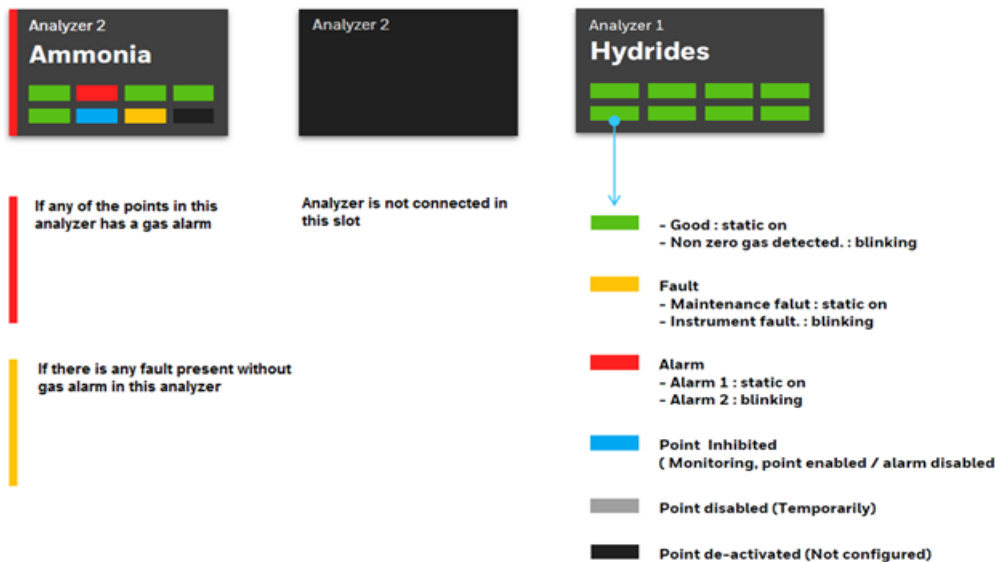

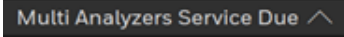
To view service due of multiple analyzers, tap on the **Multi Analyzers Service Due**  at the bottom center of the Overview screen.

Service due of all connected analyzers will be shown graphically such as remaining CC tape life, remaining days to Optic cleaning and remaining days to filter replacement.

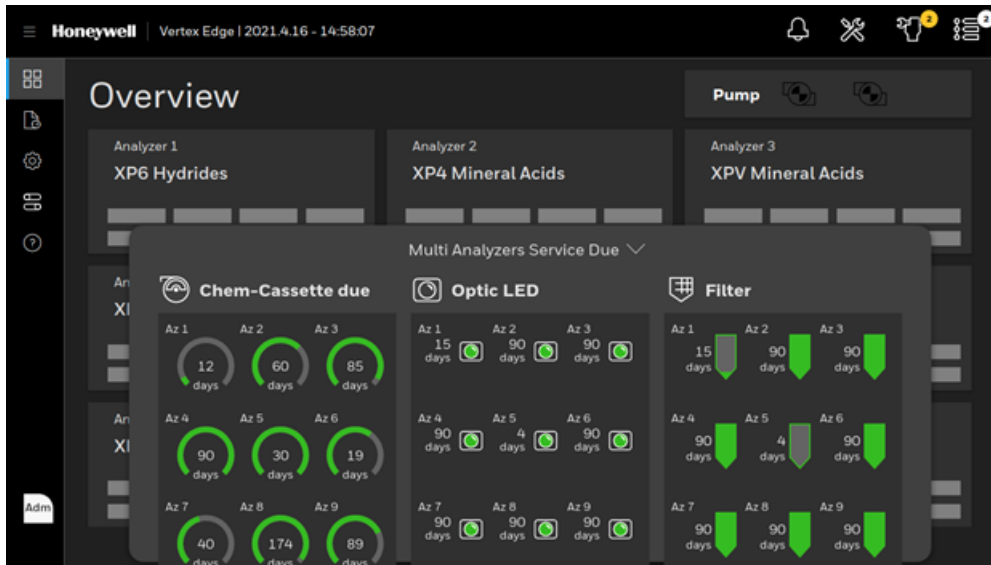

View Analyzer Status

Review status of eight points, Chemcassette life, Optic block status, flow status and filter status of a selected individual analyzer.

1. From the main menu, tap **Overview**.
2. Tap on the selected Analyzer name. Point status of the Analyzer such as gas name, gas concentration, measurement unit, location tag and point status will be displayed. The graphical representations of the point status at the bottom of point status box are the same as the Overview screen.

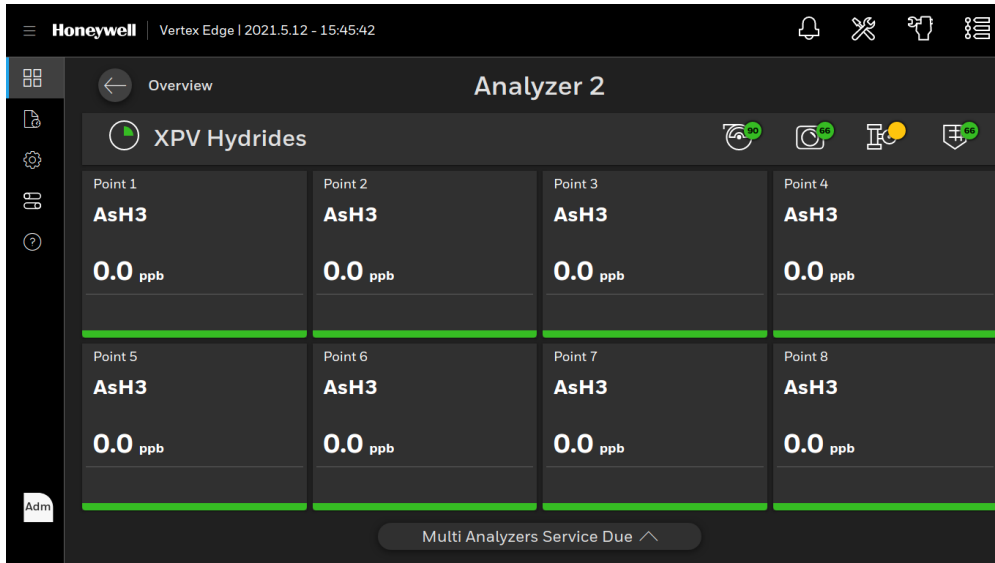

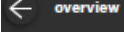
3. Tap the back overview button  to return to the Overview screen.

View Detailed Analyzer Information

1. In the left navigation panel, tap **OVERVIEW** 
2. Tap on the selected analyzer.
3. In the Components status bar,



tap on the **More Info** button .

The Analyzer Information window displays the Serial No. and the Profile ID.

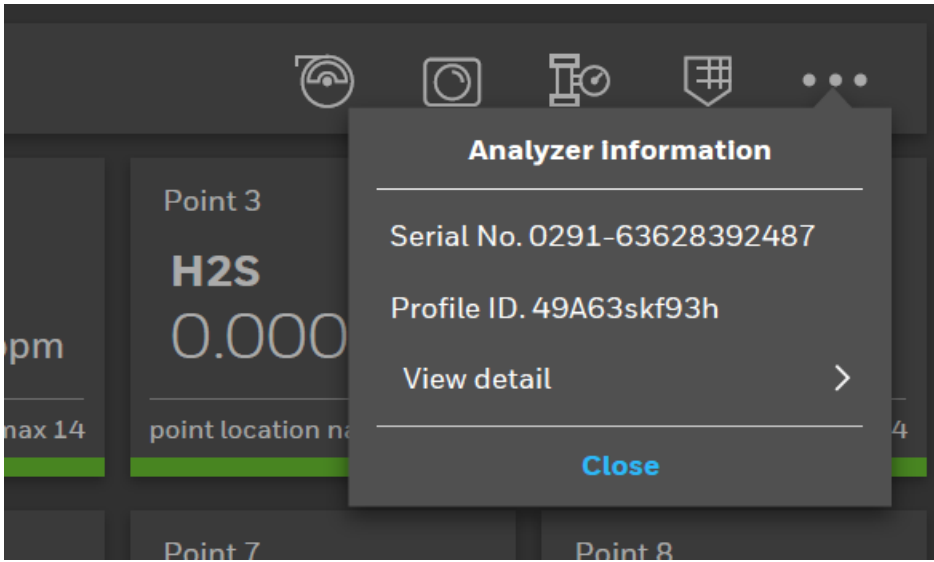

4. Tap **View detail**. The detailed info is displayed. Use the scroll bar to view the entire content.

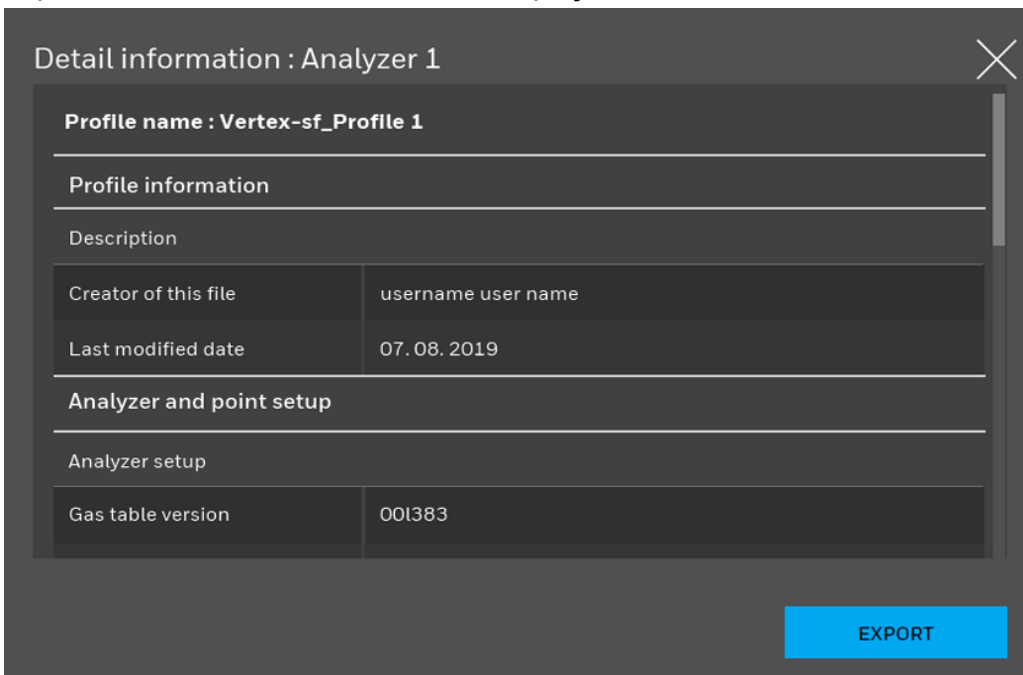

5. Optional Step to export the detailed analyzer information. Tap **Export**.

In the **File name** field, enter a file name for the export process, and then tap **NEXT**.

Select a USB port to export the information, and then tap **NEXT**.

View Detailed Point Data

Review point status, alarm settings and trend chart of the selected point. The point status includes gas name, gas concentration, measurement unit and live chart of the point. In the Point Detailed Status screen, alarm settings and k-factor are displayed along with real time gas concentration.

1. From the main menu, tap **Overview** .
2. Tap the selected Analyzer.
3. Tap the selected Point.
4. From the detailed point information screen, you can perform several operations such as:
 - Live chart.
 - Trend chart for up to 30 days.
 - Scroll left and right on the gas chart.
 - Tap on the chart to view the gas concentration value.
 - Adjust the range using the slider.
 - Change the time-line.
 - Export gas data of the trend chart.

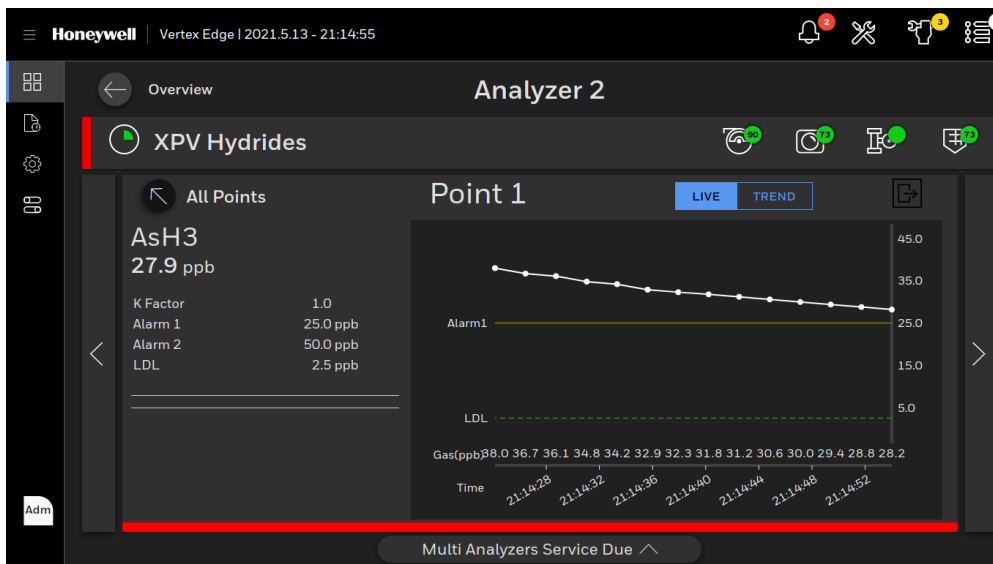

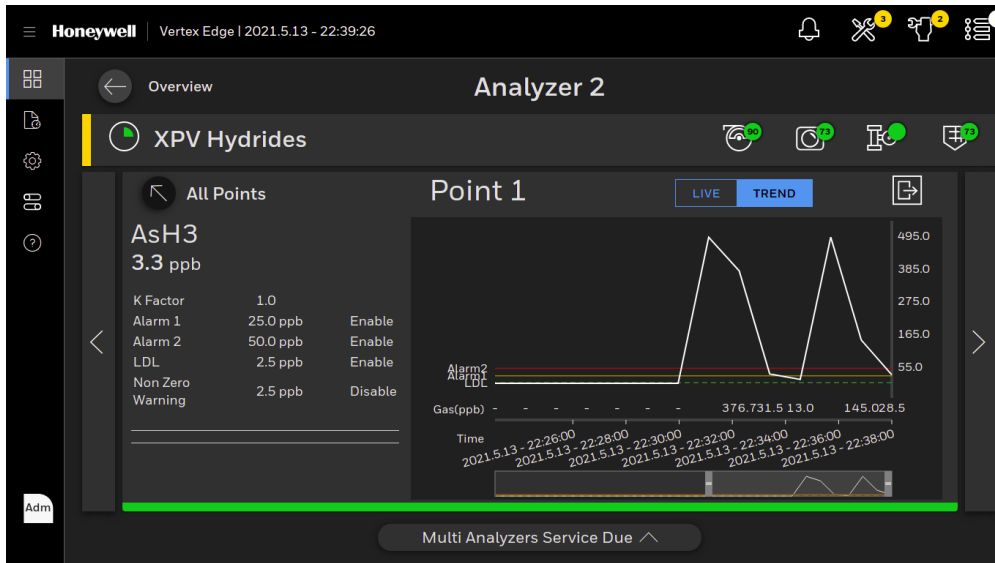

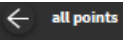



5. Tap the All Points back button  to return to the selected Analyzer screen.

Acknowledge Notifications

Acknowledge and clear gas alarms, Instrument faults, and Maintenance faults notifications.

1. From the upper right side of the main screen, tap on any of the notification icons to view

notification details.  The selected icon is highlighted in blue. The number within the circles indicate the sum of events for each notification.

	Gas Alarm
	Instrument Fault
	Maintenance Fault
	All Events

NOTE

If there is a new alarm or fault, the notification panel will expand automatically.

NOTE

High Prioritized events are filtered first.

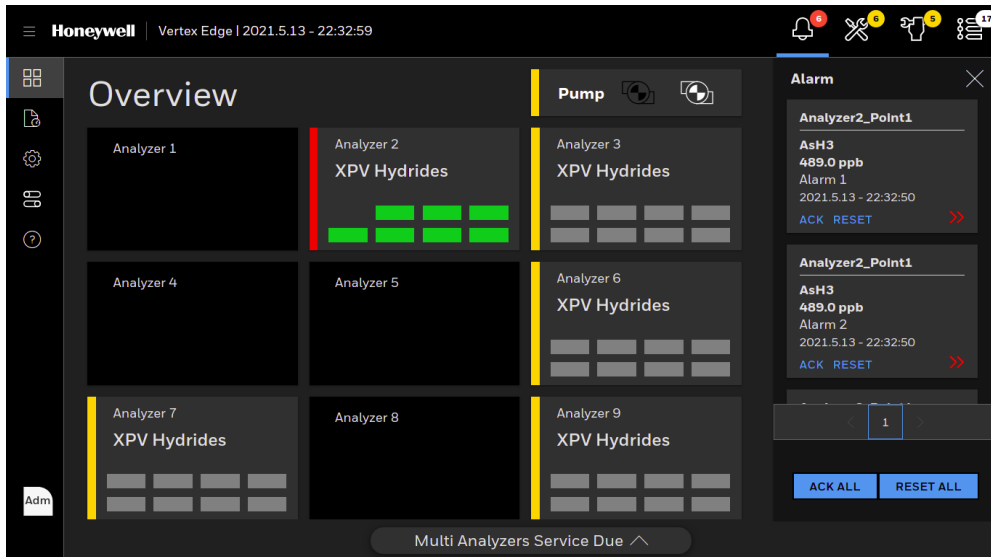

- Acknowledge or reset individual notification by tapping on individual **Ack** or **Reset** button on each notification, or acknowledge or reset all notifications from selected panel by tapping on **ACK ALL** or **RESET ALL** button.



The acknowledged event moves to the bottom of the list, and its color diminishes.

Create an HMI Backup Data

To reduce the downtime in the event of operator error, malicious software, or hardware failures at HMI PC, it is recommended to create an HMI backup and store the copy of the backup data on separate medium for fast recovery once the Vertex Edge system is configured correctly using Profile Manager. The additional medium can be an external drive, USB stick or a disk storage system depending on the IT policy of the facility.

1. From the main menu, go to System Manager > Backup & Restore
2. Tap on the Add Backup button .
3. To export the backup to a USB flash drive, select the backup in the list and tap on the EXPORT button .

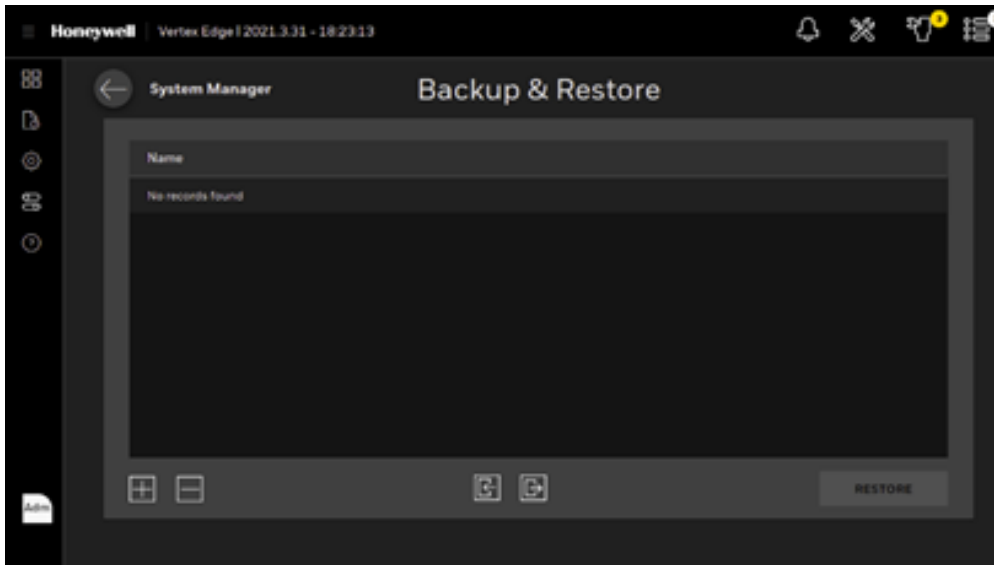

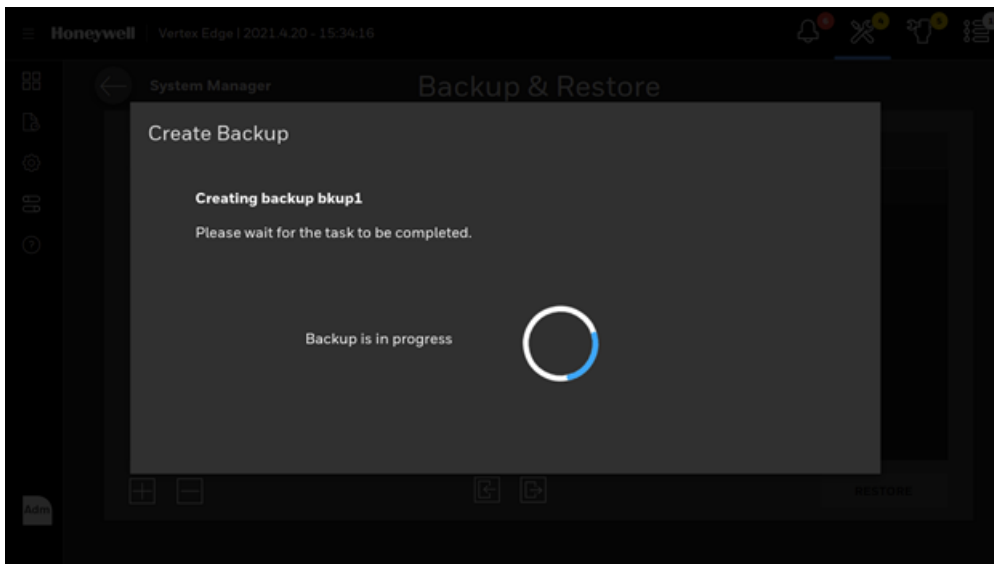
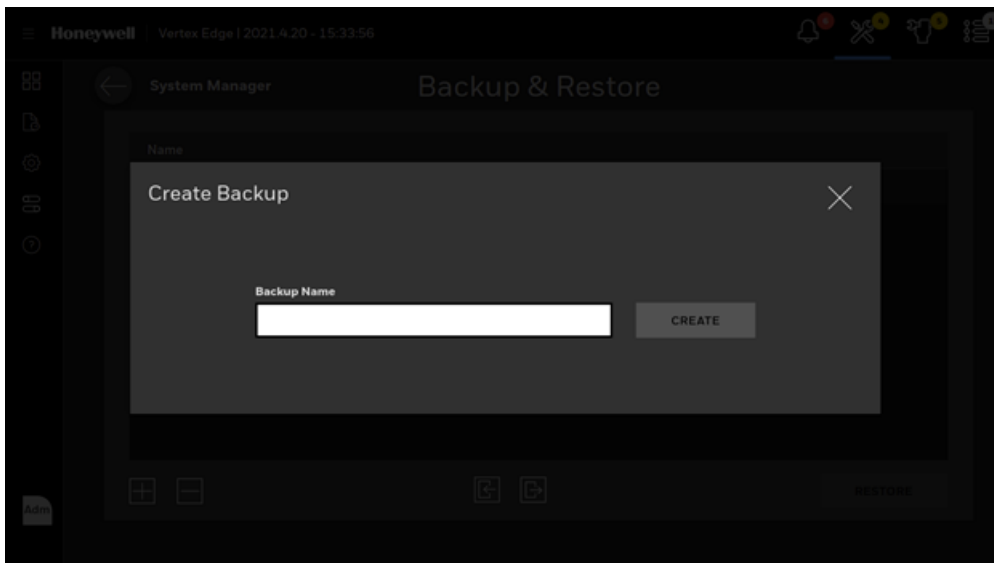
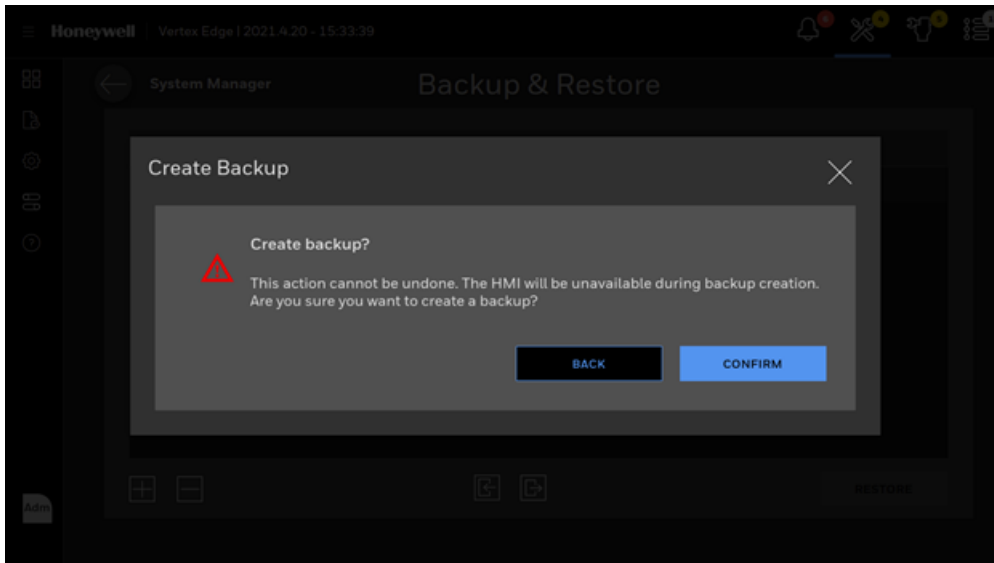

NOTE

While backing up HMI data, the HMI software will be down, and the Analyzers may generate a maintenance fault of no polls from HMI (F108). The time to back up the HMI may vary depending on how much data exists on the HMI.

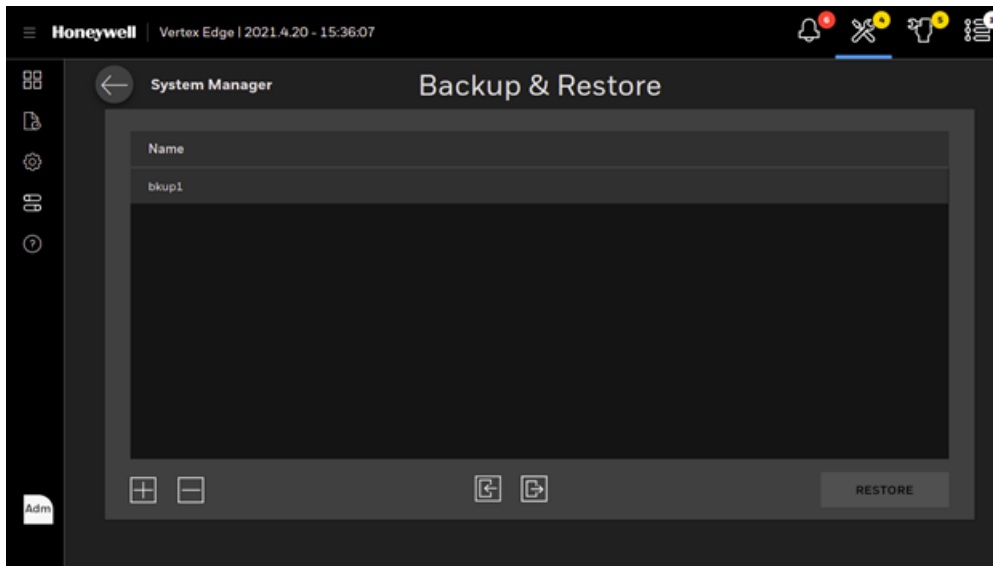

- When the backup is created, it will be shown in the list as below.



- Once an HMI Data backup is created, it can be exported to a USB flash drive for future use.
- To export the backup, tap on the EXPORT button .
- To protect the HMI data, appropriate password should be entered according to the password complexity.

NOTE

Passwords need to consist of at least 8 characters and include a lowercase, an uppercase and a special character and a number.

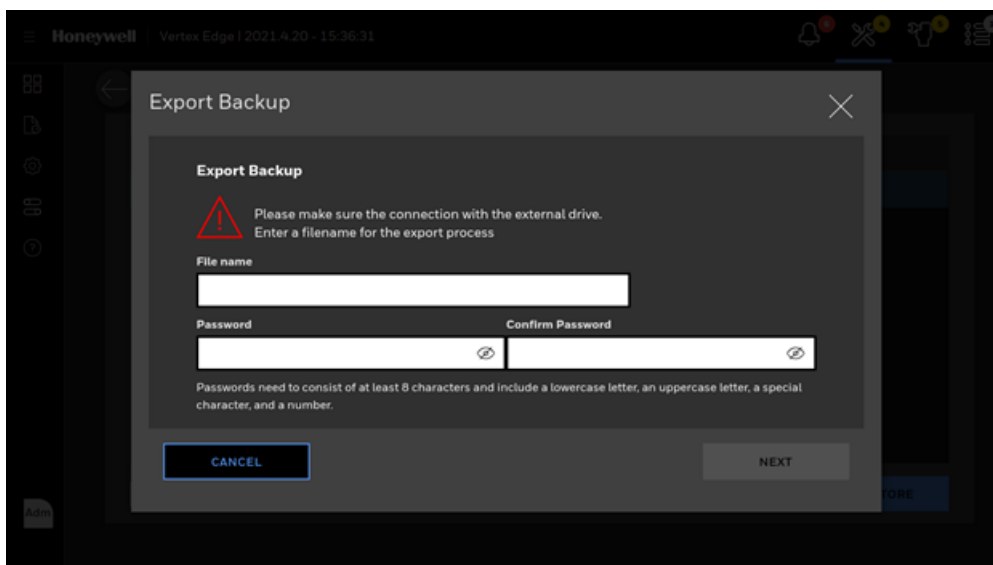

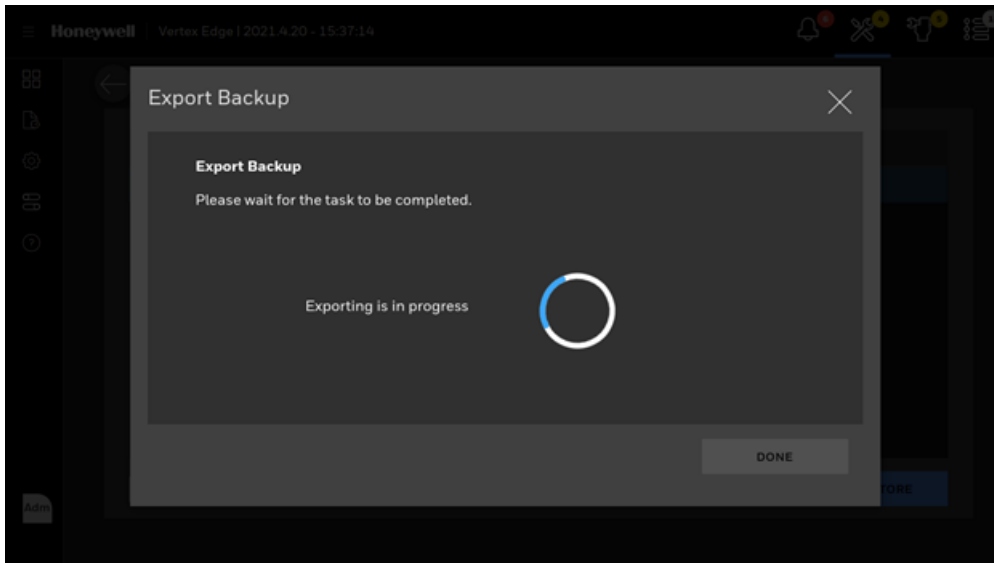

8. The time to export the HMI backup to a USB flash drive may vary depending on the size of the backup.

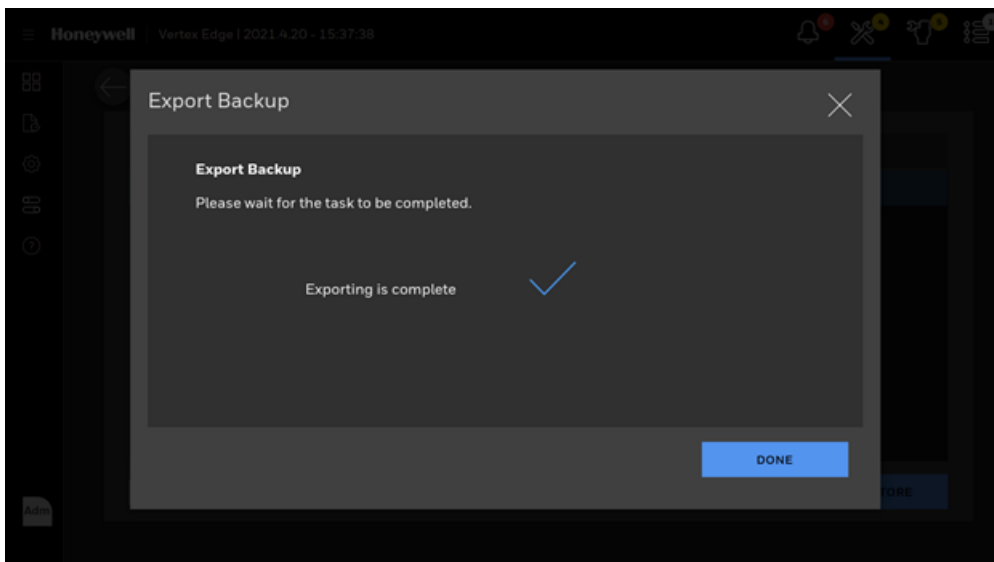

Restore HMI with Backup Data

1. From the main menu, go to System Manager > Backup & Restore
2. To import a backup from a USB flash drive, tap on the IMPORT button .
3. Select the backup file from the USB flash drive and tap on the NEXT button.

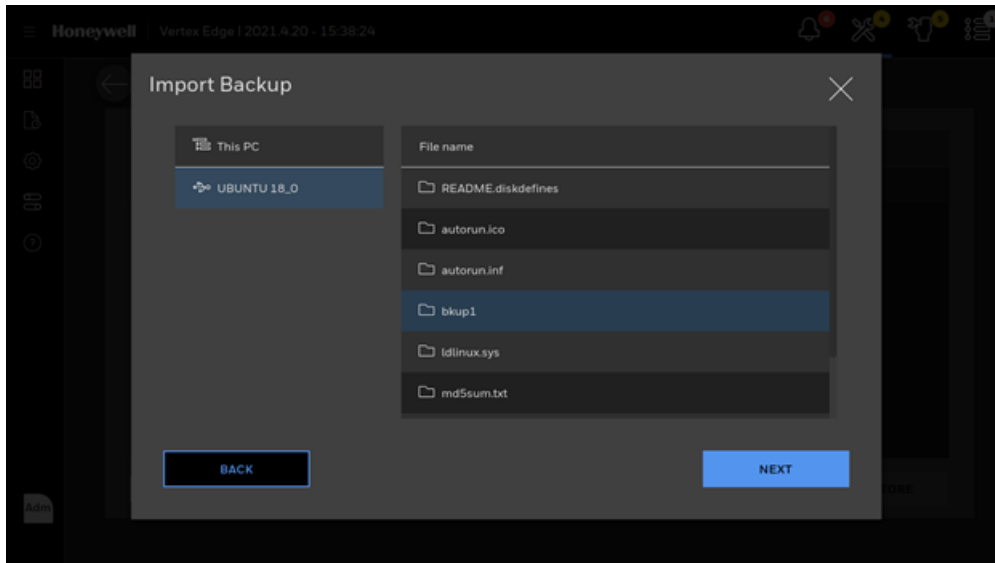

4. Enter the same password used to export the backup file.

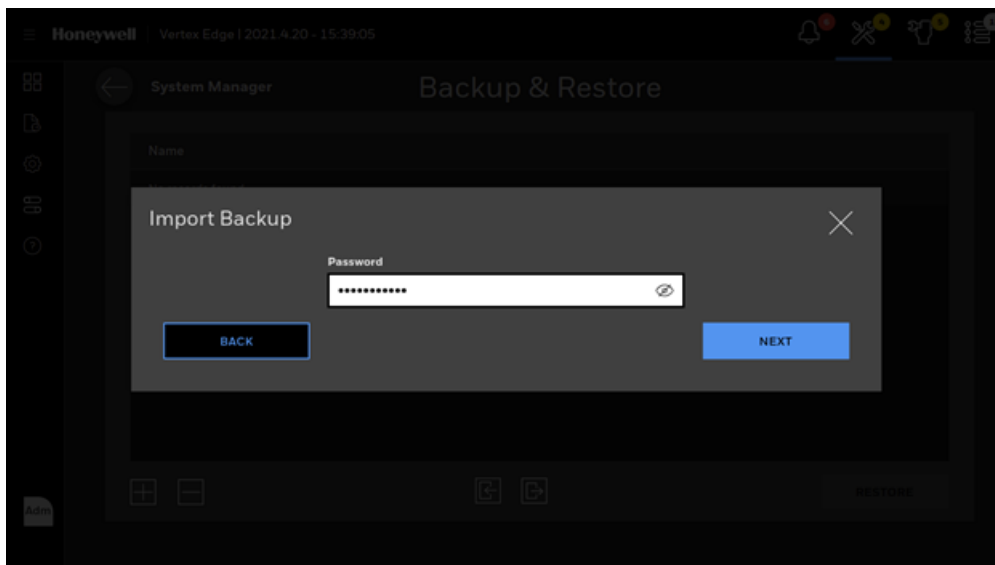

If the password is correct, the backup file will be imported. The time to import the file varies depending on the file size of the backed-up file. Once the backup file is imported, it will be shown in the backup list.

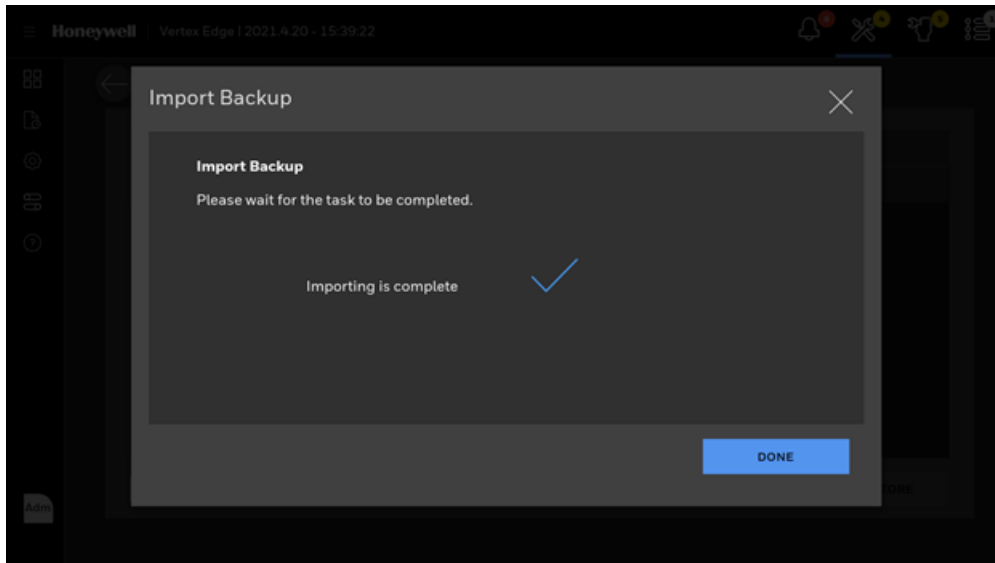

5. Select the backup from the backup list and tap on the RESTORE button to restore the HMI.
6. Tap on the Confirm button.

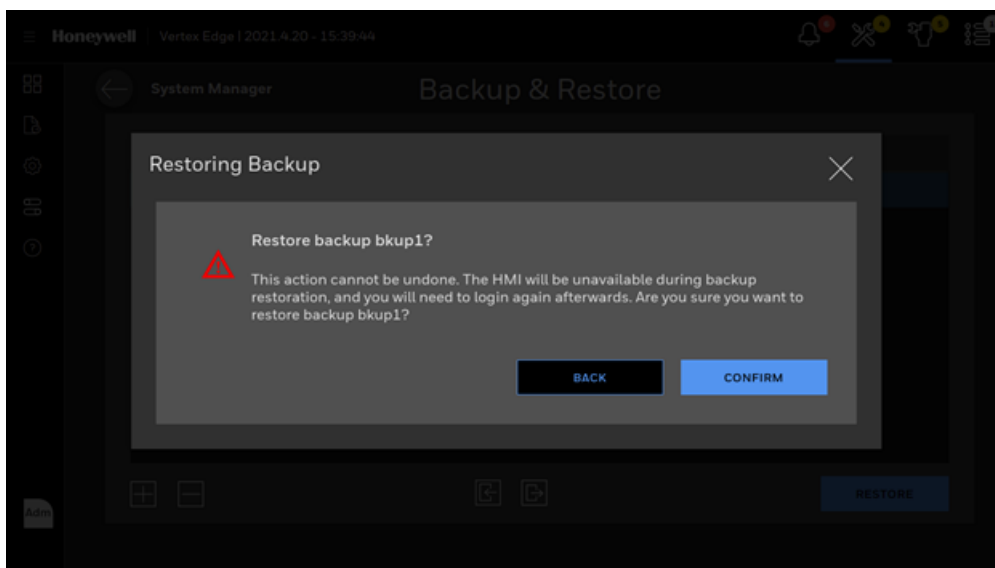

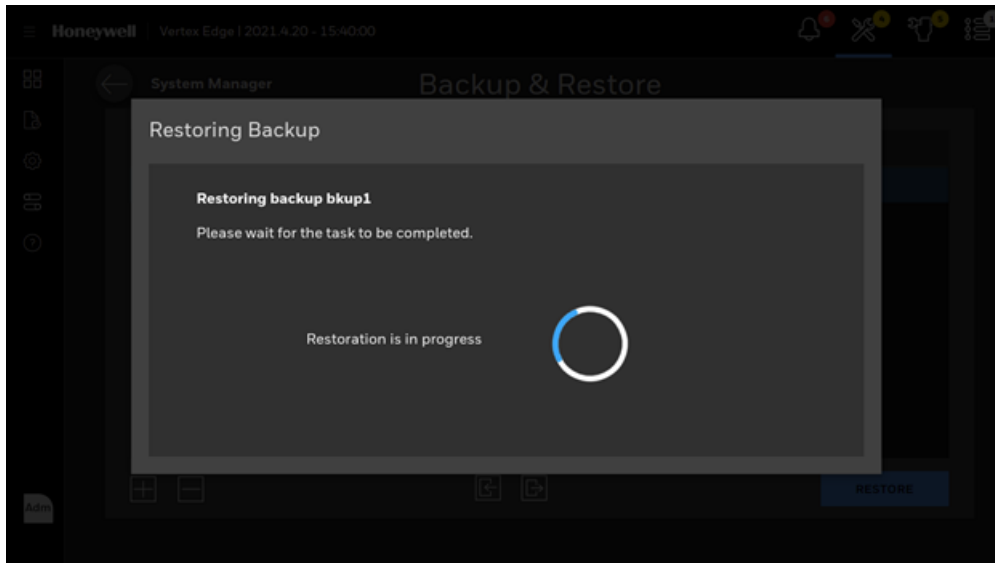

NOTE

All HMI data including profile, event history and trend data will be restored to the moment when the HMI data was backed up. Restoration of HMI data cannot be undone. When the restoration is complete, the user will log out and the screen will move to Overview automatically.

Reset Passwords to Defaults

It is to reset user accounts and password to factory defaults when a user forgets the passwords for all administrator users. Please contact Honeywell Analytics to get the password reset file for the specific Vertex Edge system.

1. From the main menu, go to System Manager > Password reset
2. Select an appropriate password reset file from a USB flash drive and tap on the RESET PASSWORD button.

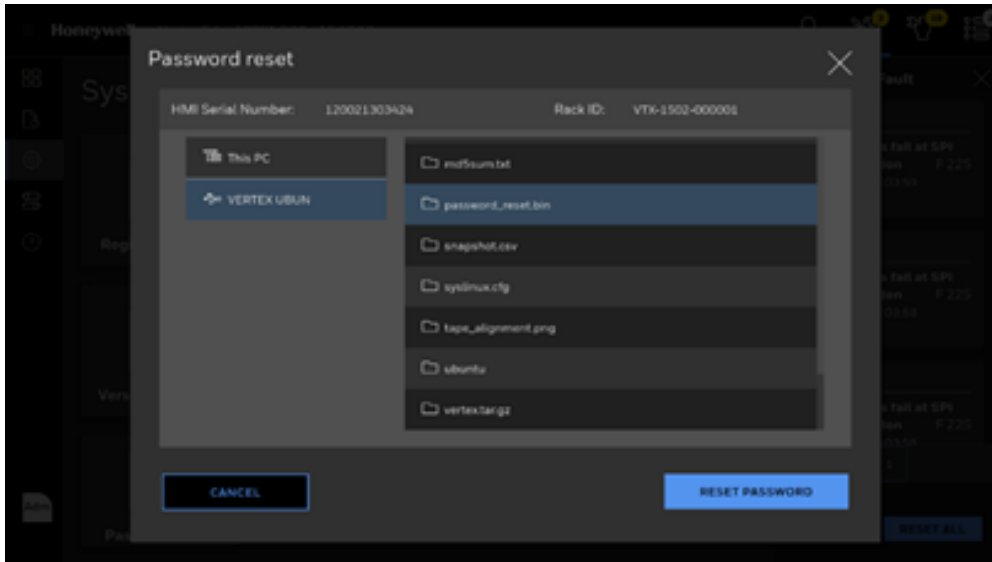

When you request a password reset file, you need to provide HMI serial number and rack ID. Both information can be checked in Version Manager.

NOTE

When the password is reset, the user will automatically log out.

Database settings

The retention period of logged gas data and event records can be configured in Database Settings.

1. From the main menu, go to System Manager > Profile Manager
2. Select Database tap and configure the data retention period. The default setting for event record is OFF (no purge) and the retention period of the logged gas data is 90 days.

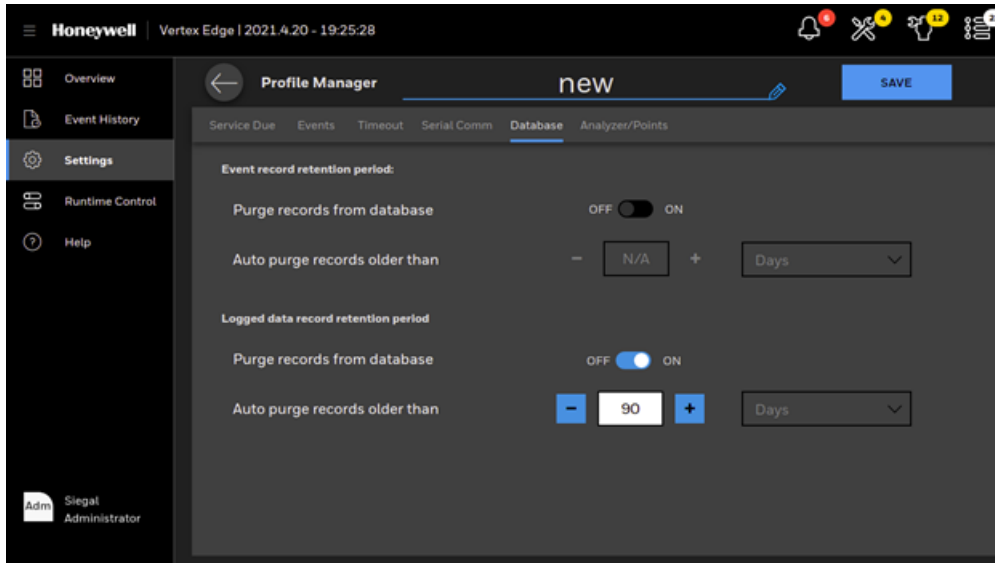

Alternate The Pump close to Due Date

Alternate the pump every 6 months.

1. From the main screen, tap on the Pump maintenance button . The pump icon is highlighted in yellow when pump uptime is reaching to the end and service is required.



- In the pump maintenance window, the uptime is highlighted in yellow. Tap **Pump Alternate**.

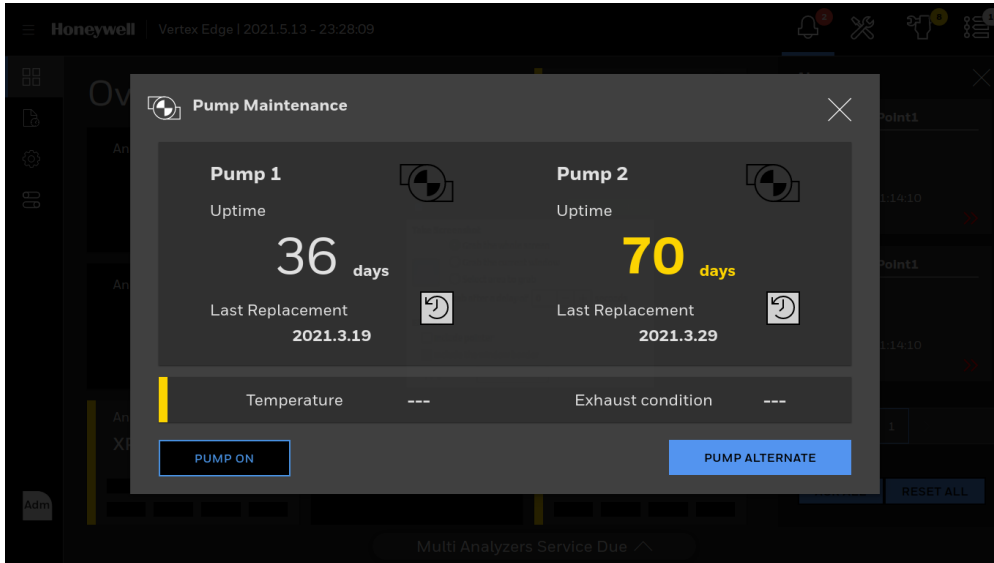

- Tap **CONFIRM** to start the pump alternation process.
- Optional step. Tap on the Reset button .
- Tap **CONFIRM** to reset the counted uptime days. The highlighted uptime resets to zero.

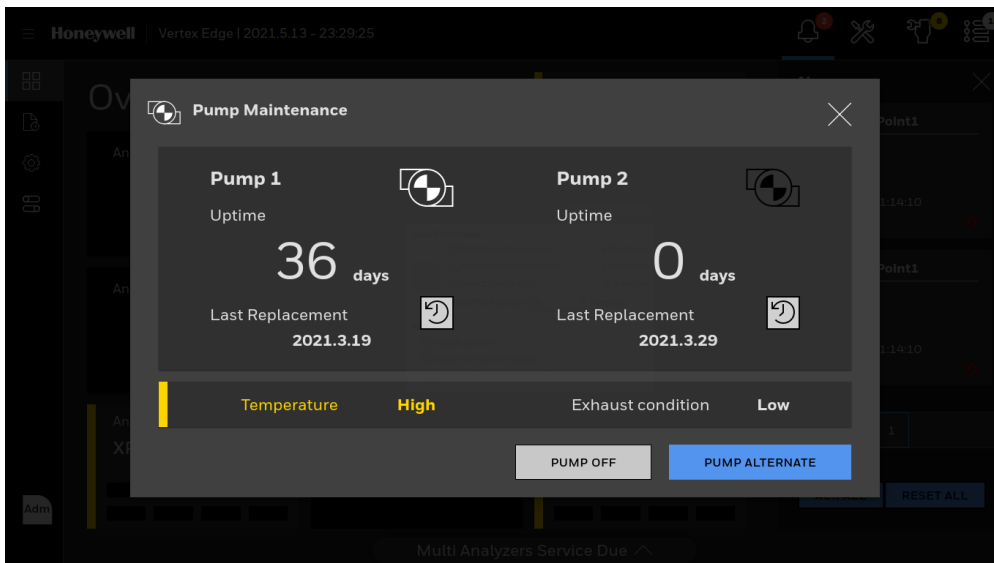

- Optionally the temperature status in the pump module and high pressure status at exhaust line can be checked. When there is any issue in temperature and exhaust pressure, the text of Temperature and Exhaust condition will be highlighted in yellow.

Turn a Pump On And OFF

You can turn ON or OFF a pump when all the analyzers are out of the monitor mode.

1. In the left navigation panel, tap **OVERVIEW** 
2. Tap the pump button



3. In the Pump Maintenance window, tap **PUMP OFF** or **PUMP ON** as needed.

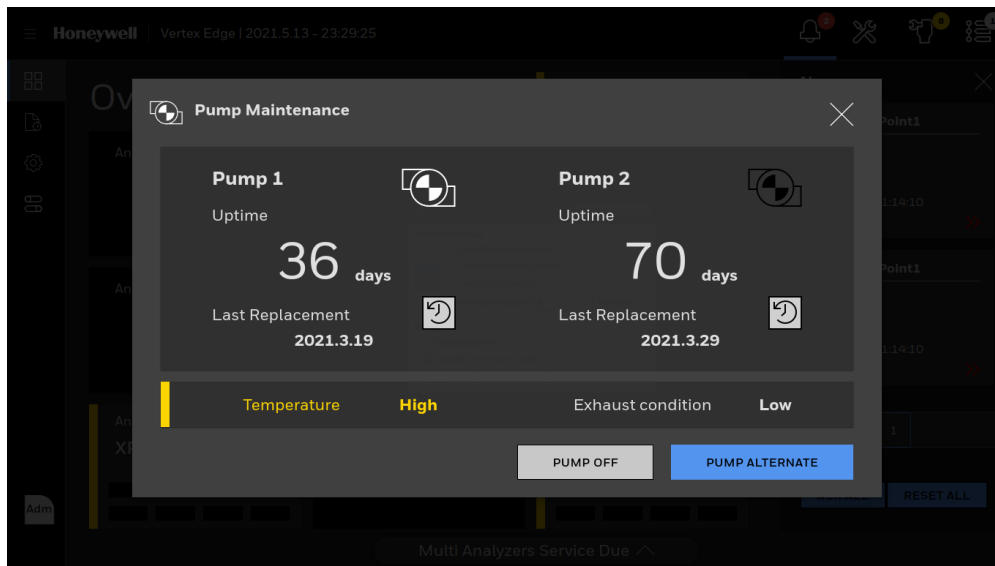

Turn the Monitoring Mode On and OFF

1. In the left navigation panel, tap **OVERVIEW** 
2. Tap on the selected analyzer.
3. In the Components status bar,



tap on the selected analyzer's gas family name.

4. In the Operation Control window, select **Monitoring mode, ON or OFF**

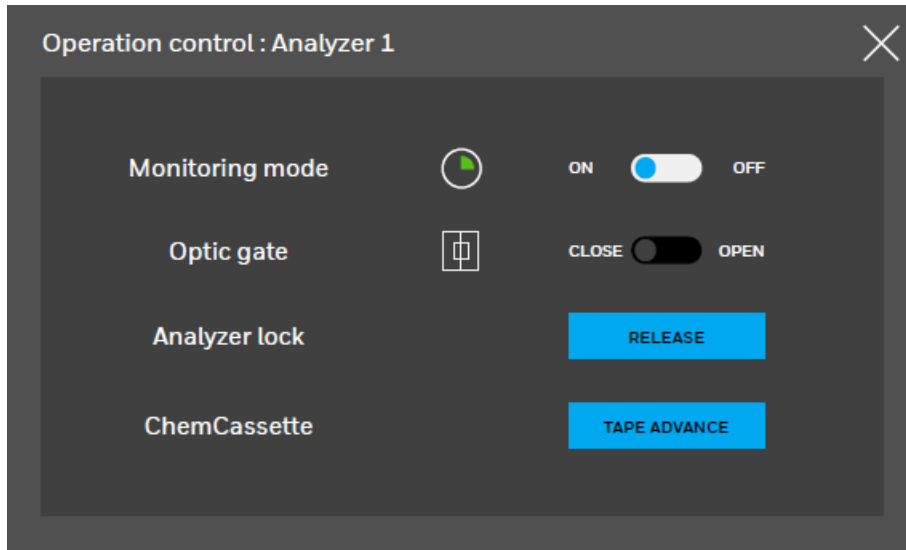

NOTE

The Optic gate is closed when Monitoring mode is ON.

Open the Optic Gate

1. In the left navigation panel, tap **OVERVIEW** 
2. Tap on the selected analyzer.
3. In the Components status bar,



tap on the selected analyzer's gas family name.

4. In the Operation Control window, shift the **Optic Gate** slider to **OPEN**.

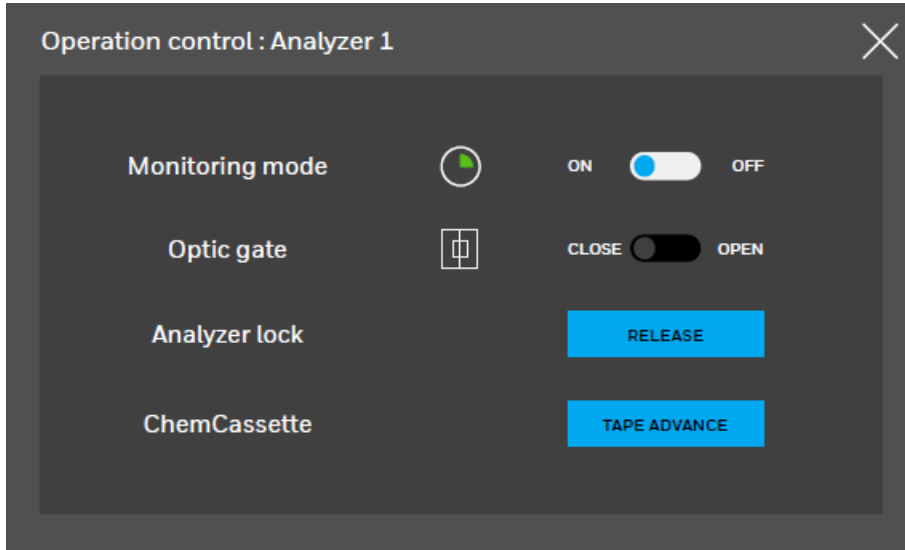

NOTE

The Optic gate is closed when Monitoring mode is ON.

Release the Analyzer Lock

1. In the left navigation panel, tap **OVERVIEW** 
2. Tap on the selected analyzer.
3. In the Components status bar,



tap on the selected analyzer's gas family name.

4. In the Operation Control window, tap **RELEASE** next to **Analyzer lock**

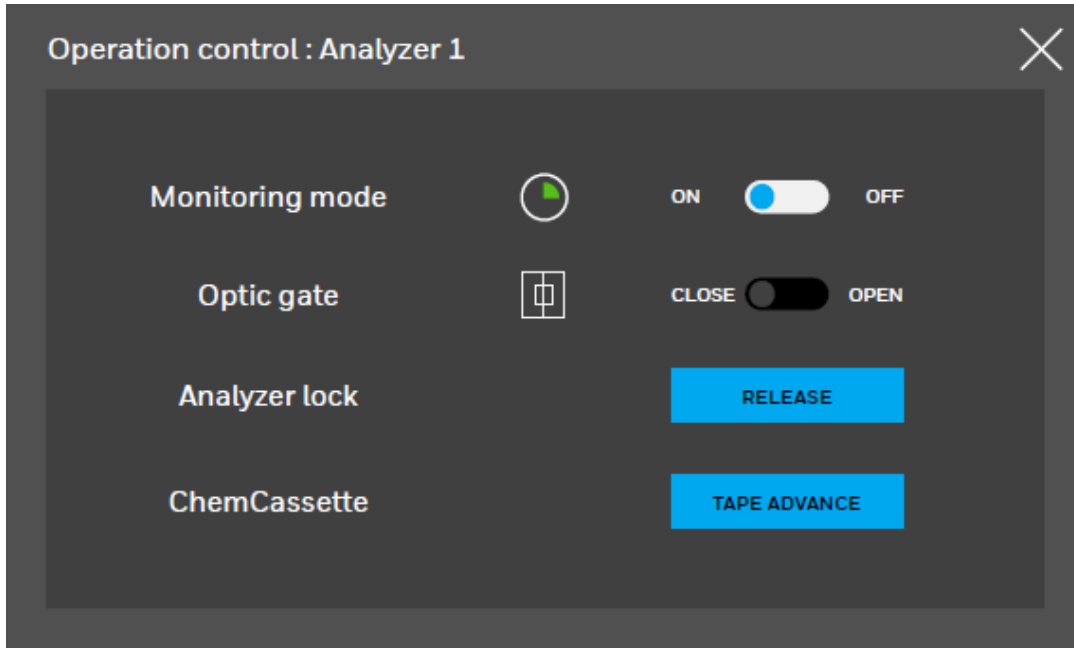

Advance the Chemcassette Tape

1. In the left navigation panel, tap **OVERVIEW** 
2. Tap on the selected analyzer.
3. In the Components status bar,



tap on the gas family name.

4. In the Operation Control window, tap **TAPE ADVANCE** next to **Chemcassette**

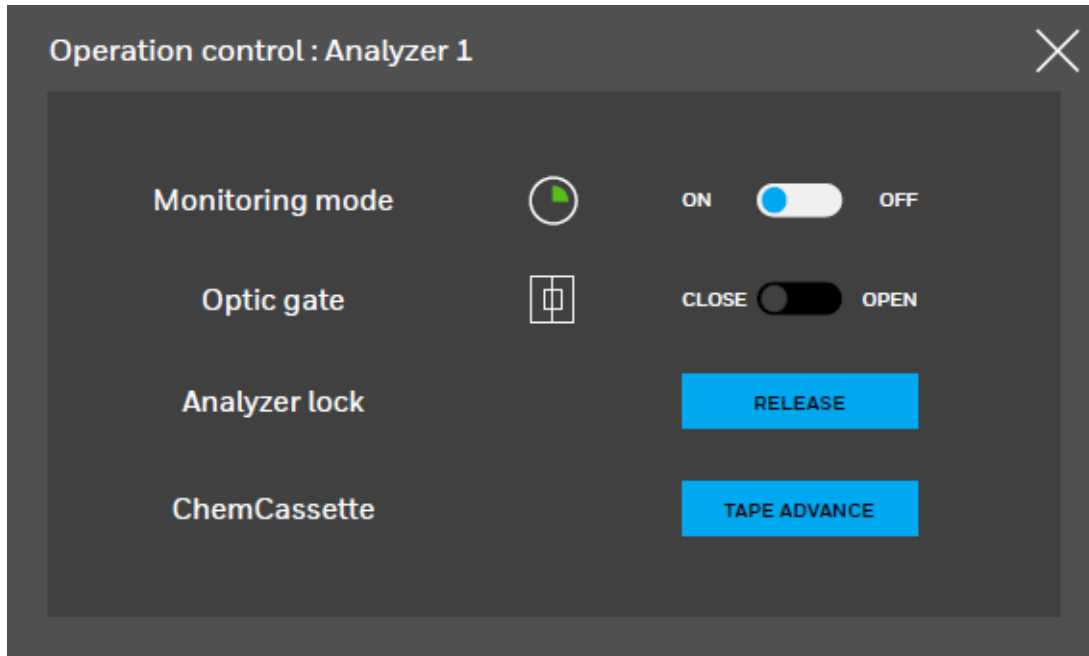

Adjust the Optic Block

1. In the left navigation panel, tap **OVERVIEW** 
2. Tap on the selected analyzer.
3. In the Components status bar,



tap on the Optic

Block button .

4. In the Optic Block window, tap **ADJUST OPTICS**, and then tap **CONFIRM**. Follow onscreen instructions and finally tap **NEXT**.

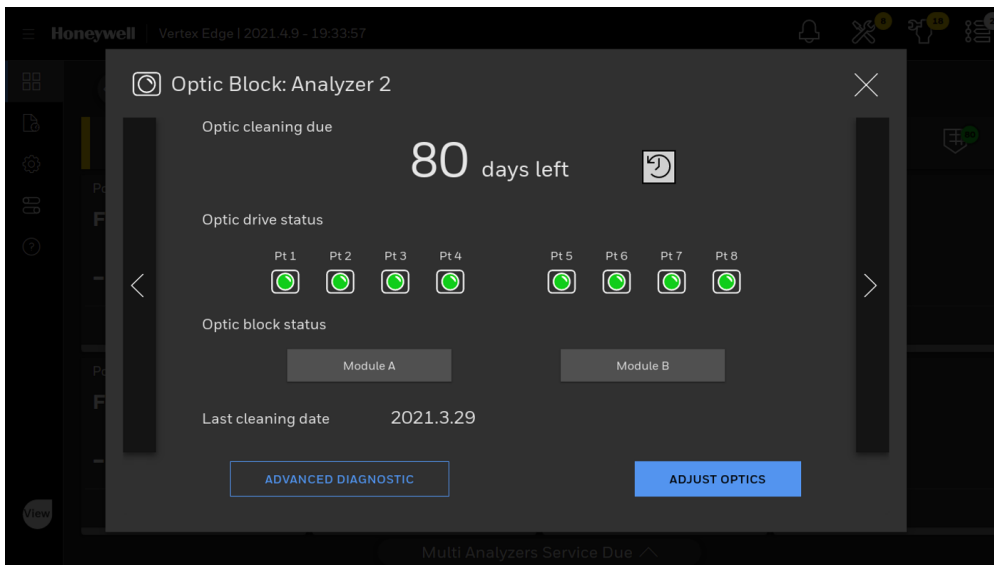
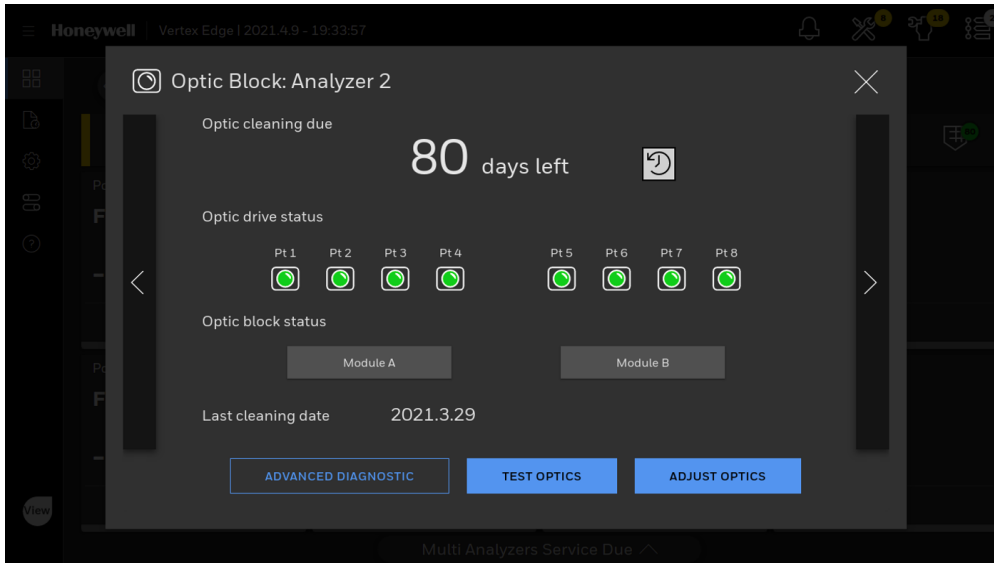

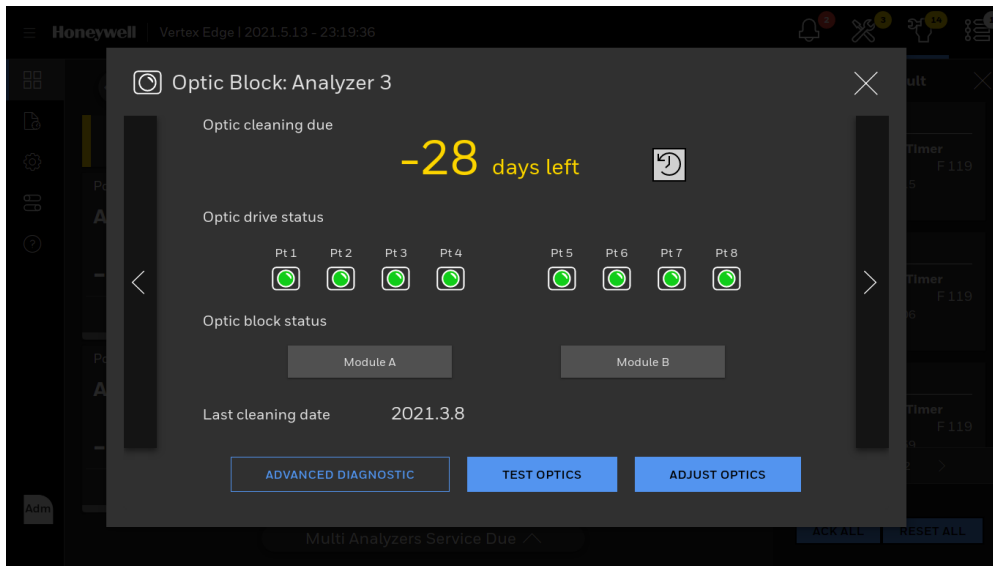

5. Alternate Step. If the cleaning date has expired, the Optic Block button is highlighted in yellow,  as well as the due date, the Optic Drive, and a Module status in the Optic Block window. Tap **ADJUST OPTICS** and clean the Optics block by referring to Clean the Optics

section in Maintenance first. Tap ADJUST OPTICS and reset the count.



6. Optional Step. Tap the **Reset Count** button  to Reset the configured Optic cleaning interval.

Test Optic Block

1. Exit monitor.
2. In the left navigation panel, tap OVERVIEW .
3. Tap on the selected analyzer.
4. In the Components status bar. Tap on the Optic Block button .
5. In the Optic Block status screen, tap on the Test Optics button.

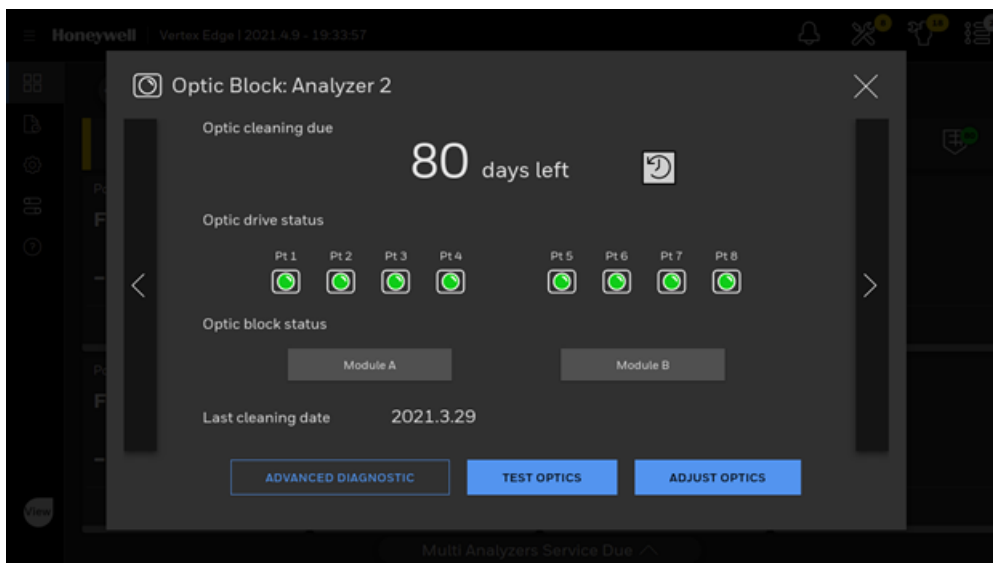

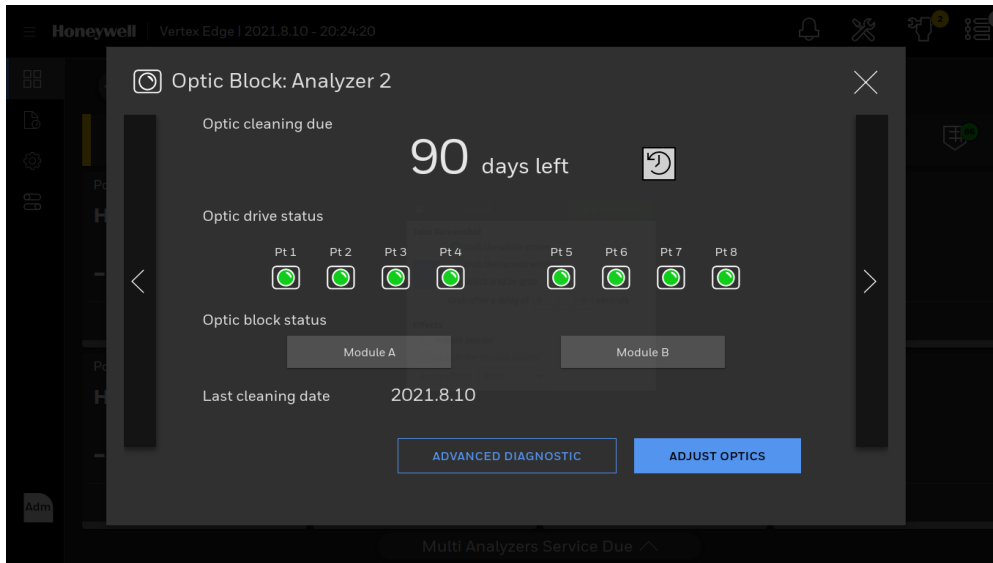

Prepare a tape leader and follow the instruction to test optic block. The whole process is manual operation.

When Optic block is tested with light gray tape and optic readings meet the criteria of color change, the alarm level 1 will be generated

When Optic block is tested with dark gray tape and optic readings meet the criteria of color change, the alarm level 2 will be generated

NOTE

While testing optic block, real gas alarms may be generated.

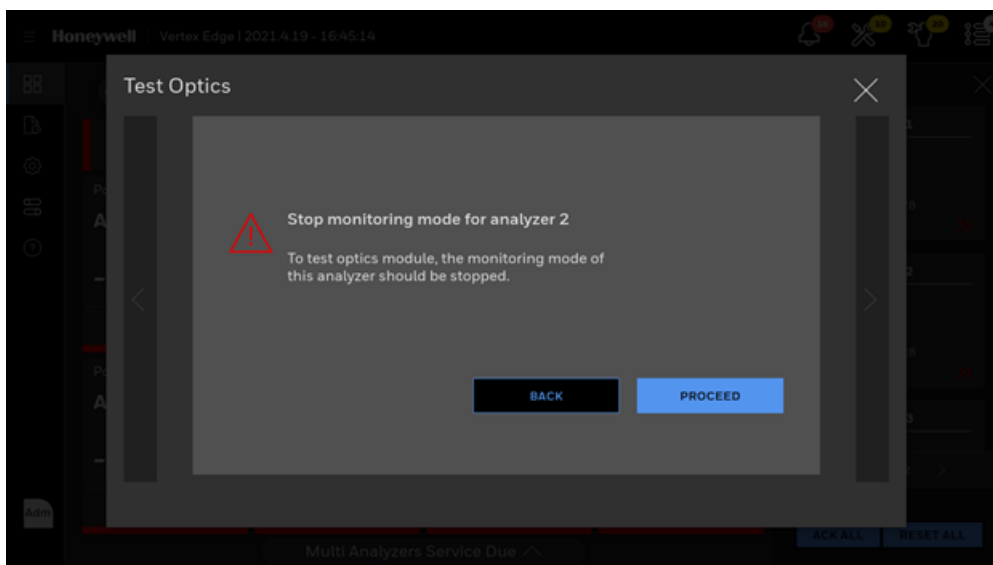

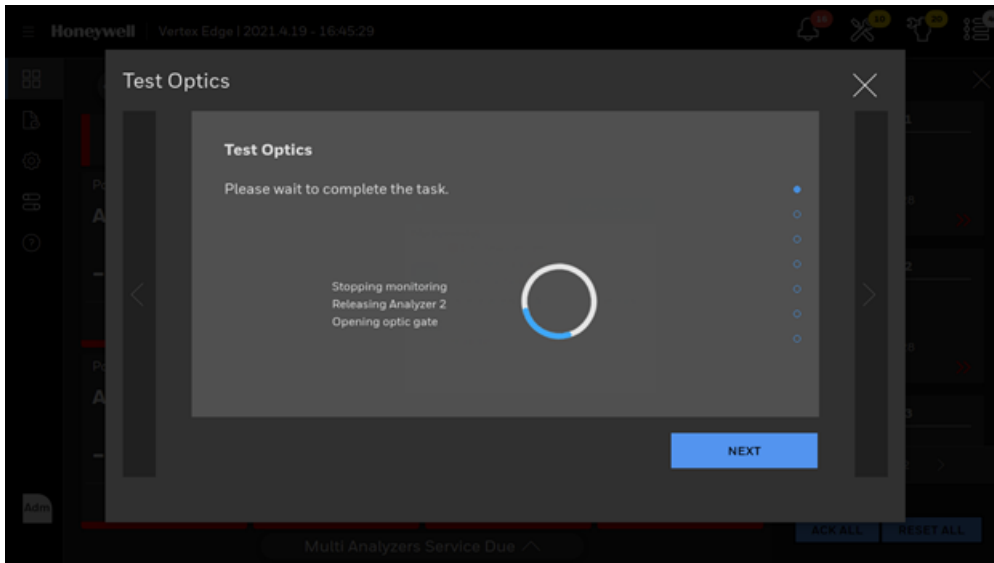

6. Insert the white tape leader to the Optic block carefully to make sure white tape leader is placed between two Optic blocks and tap on the NEXT button.

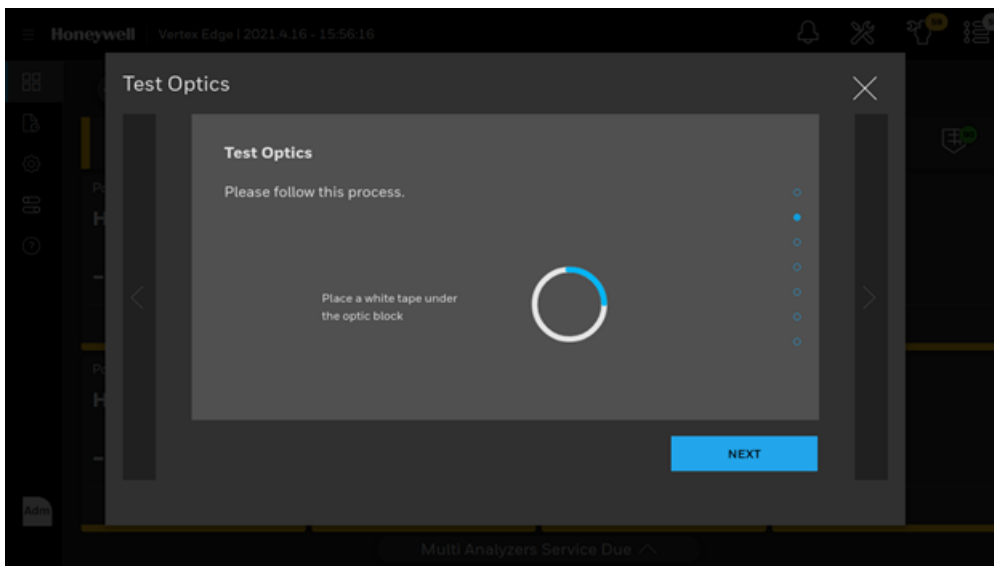

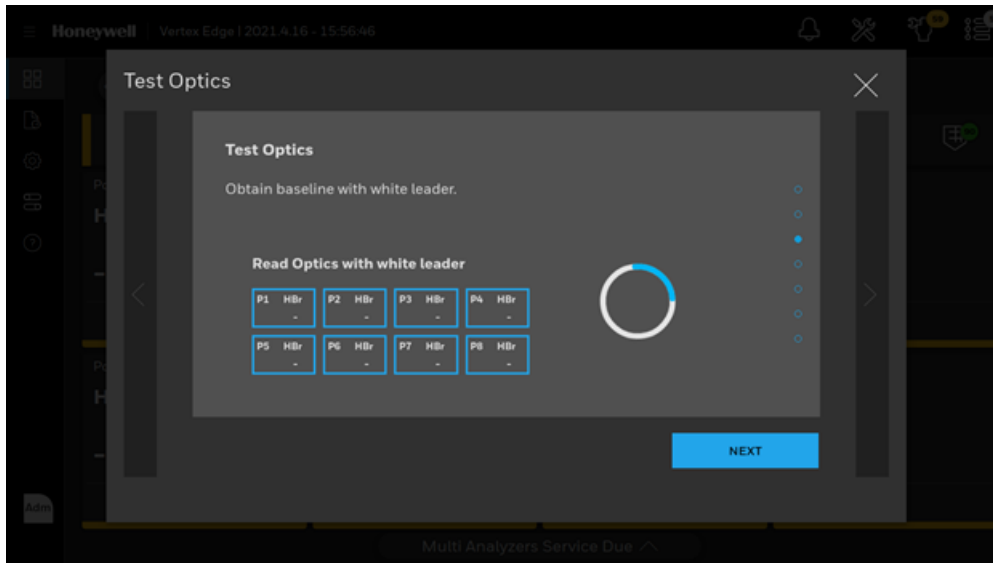

7. Insert the light gray tape leader to the Optic block carefully to make sure light gray tape leader is placed between two Optic blocks and tap on the NEXT button.

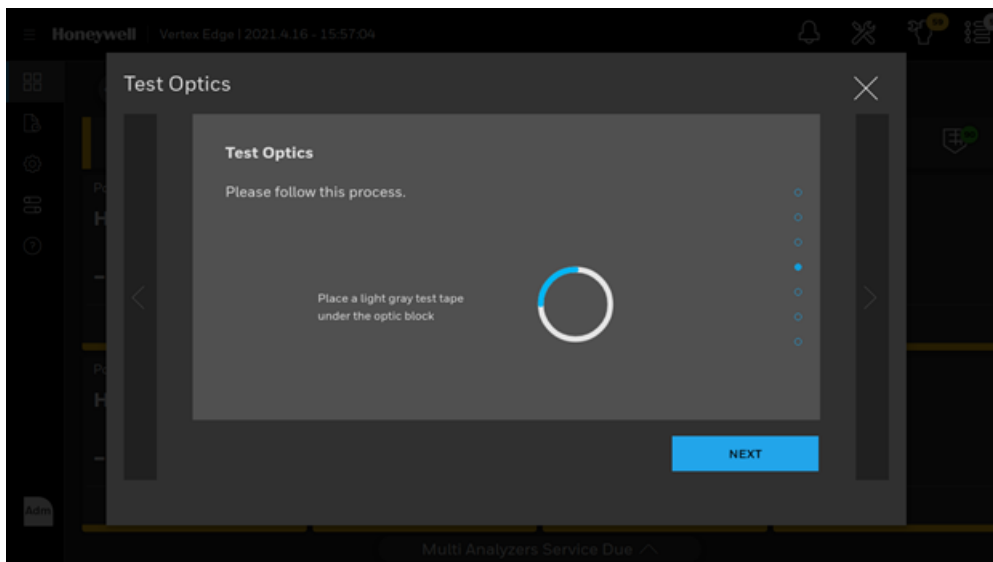

8. If color change (stain development) is detected by Optic blocks, the Analyzer computes gas concentrations and generate a gas alarm¹.

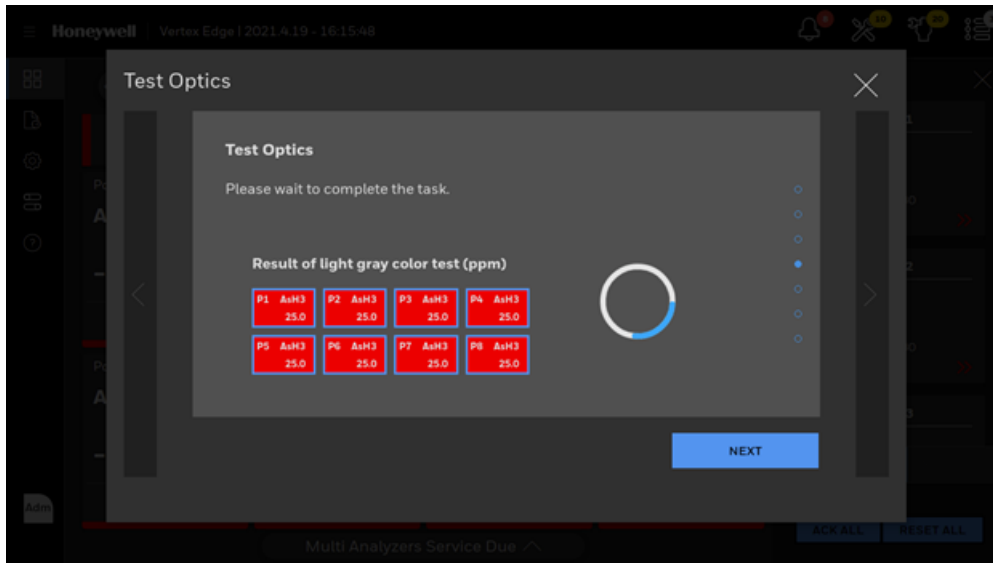

9. Insert the dark gray tape leader to the Optic block carefully to make sure dark gray tape leader is placed between two Optic blocks and tap on the NEXT button.

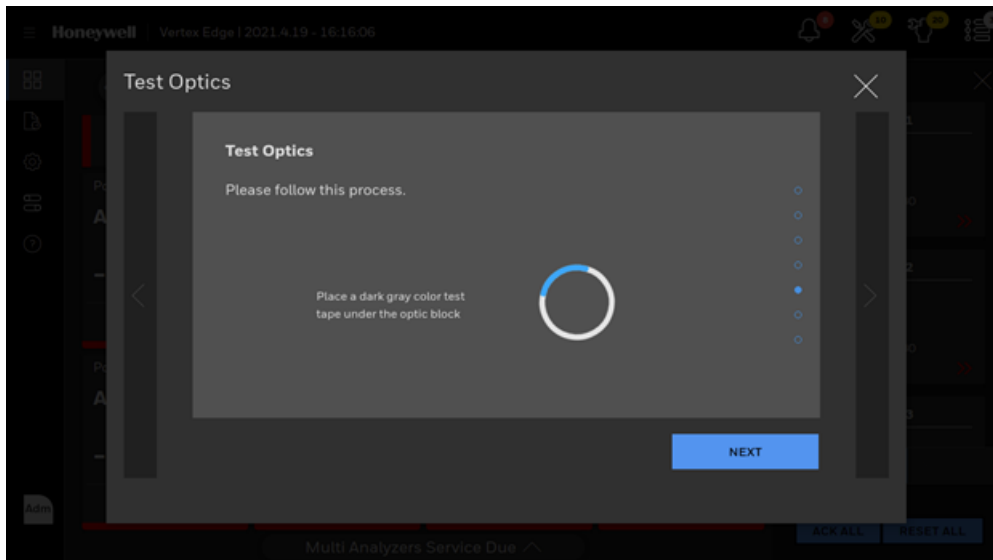

10. If color change (stain development) is detected by Optic blocks, the Analyzer computes gas concentrations and generate a gas alarm².

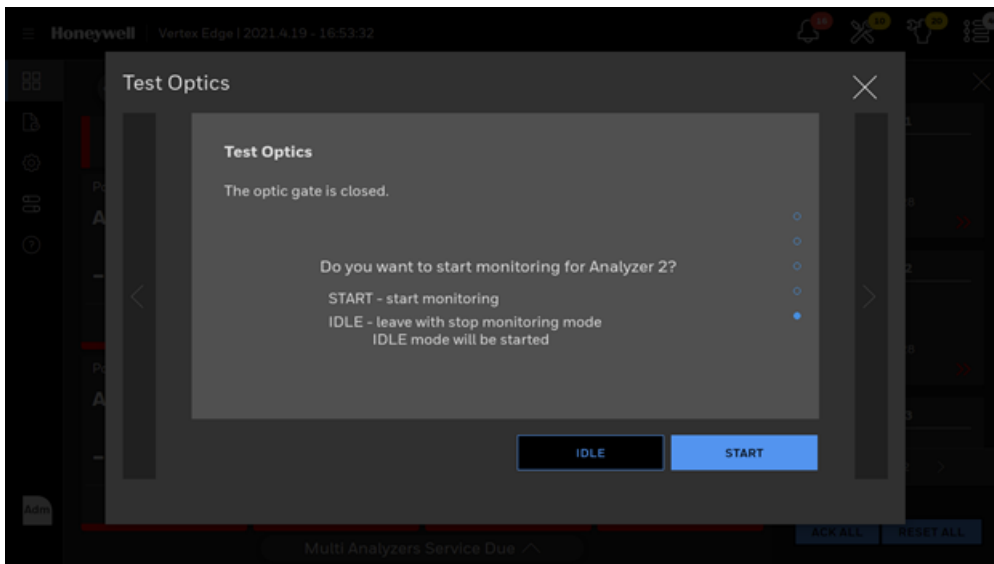
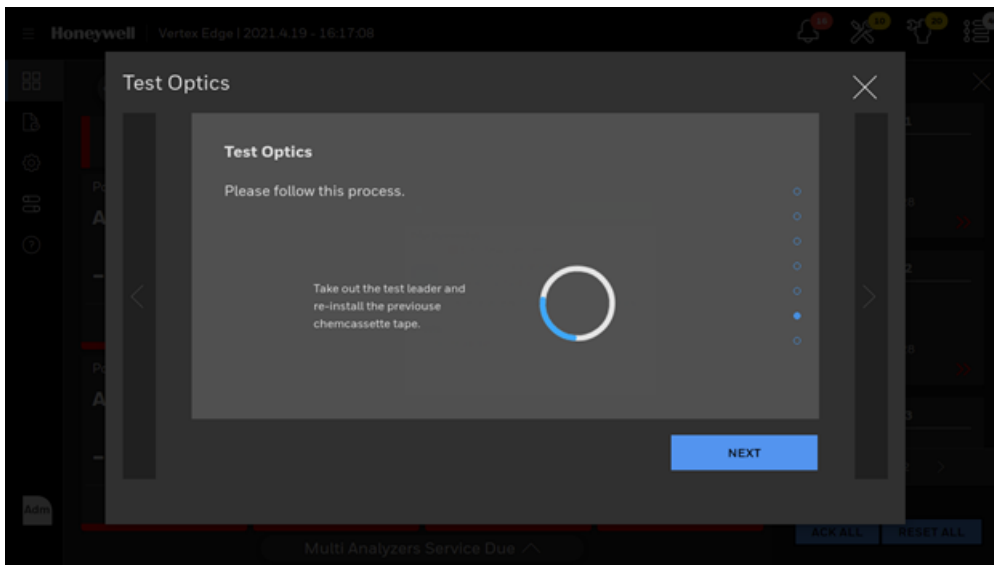
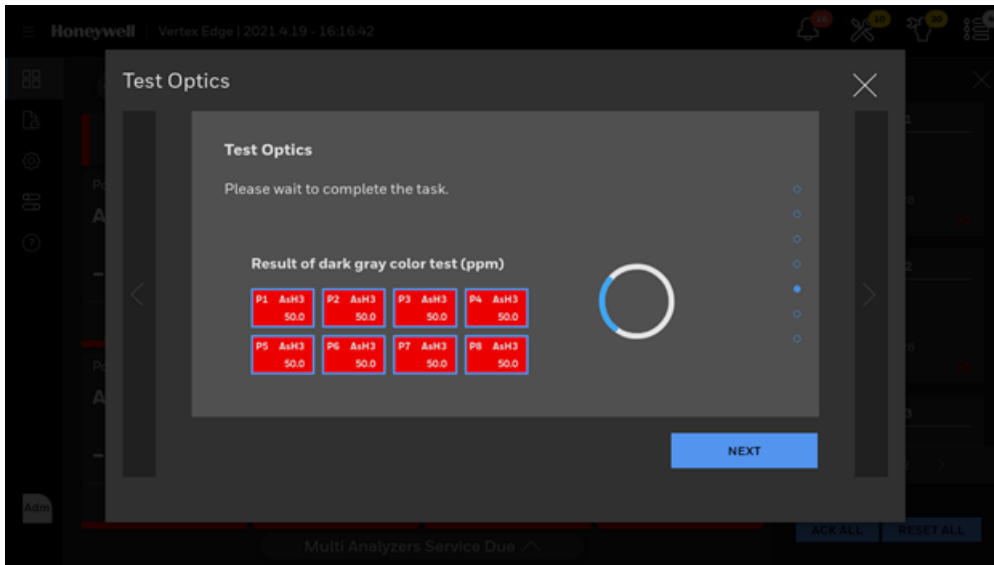

View Optic Status

View Optic status of the selected analyzer such as optic drive status, optic block status and optic cleaning due.

1. From the main menu, tap Overview
2. Tap on the selected Analyzer name
3. In the Components status bar, tap on the OPTIC Status button 

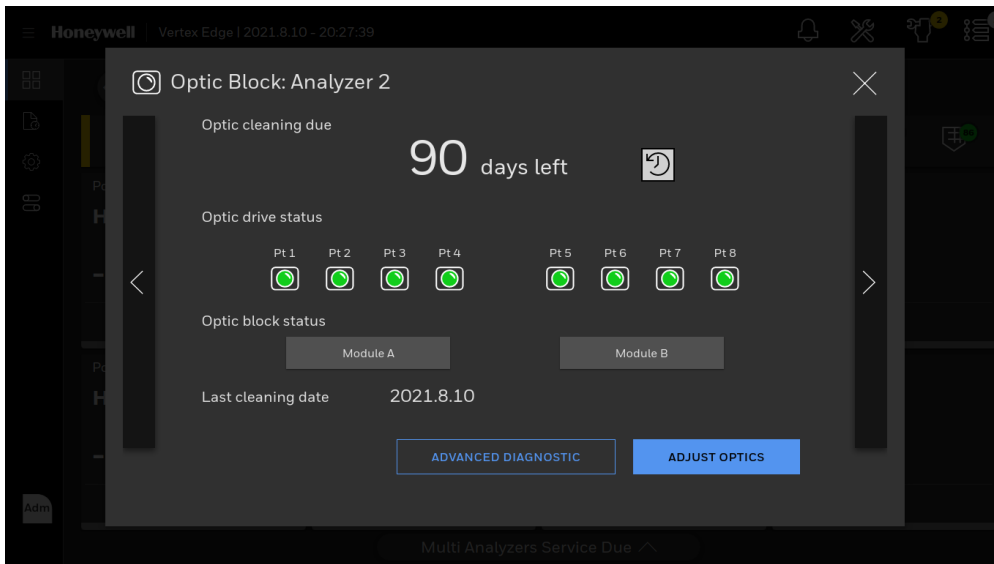
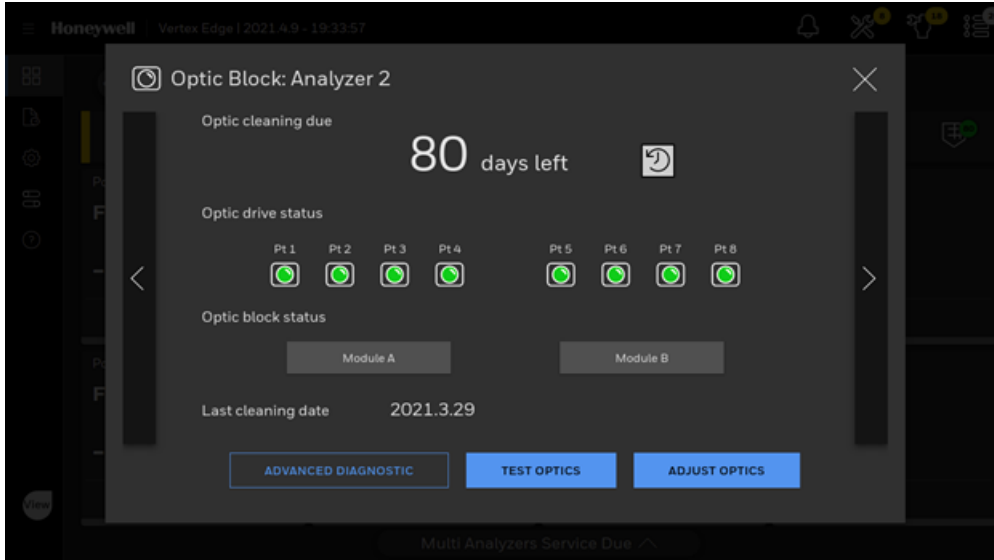

4. Alternatively Tap ADVANCED DIAGNOSTIC to view LED drive levels for eight points and

check whether the LED drive levels are within the recommended range.

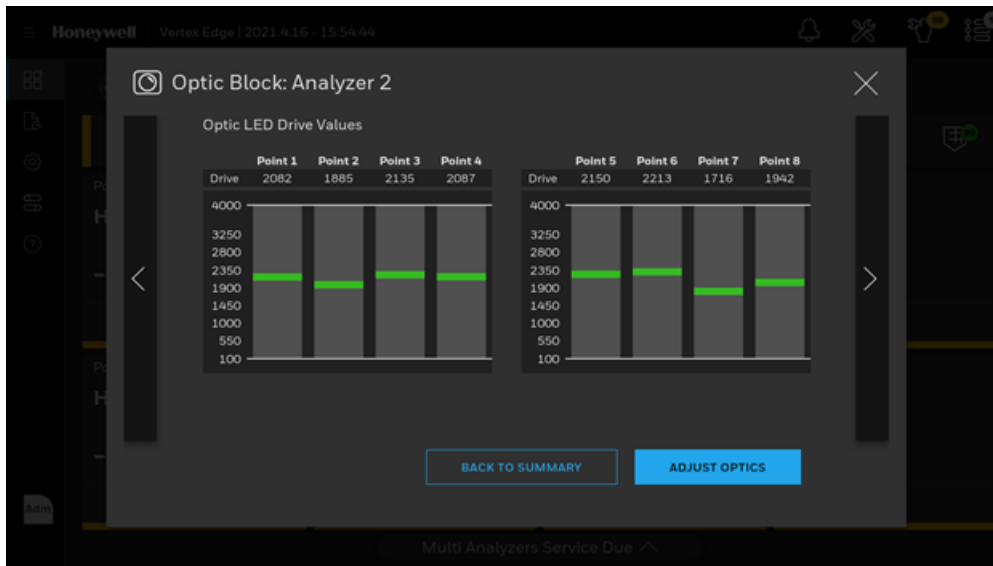

Sample Line Filter Replacement Counter

1. In the left navigation panel, tap **OVERVIEW** 
2. Tap on the selected analyzer.
3. In the Components status bar,



tap on the **Filter** button .

Either the regular replacement window highlighted in green or the expired time window highlighted in yellow is displayed.

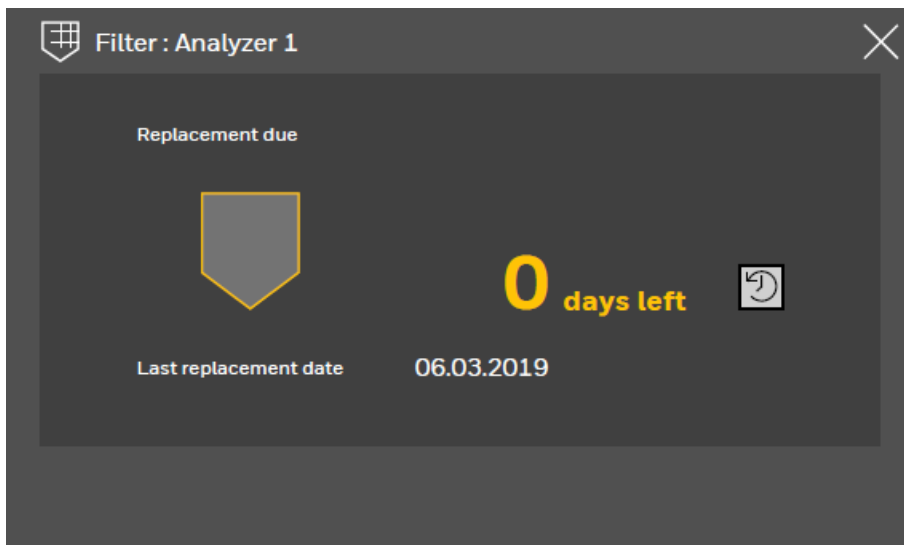
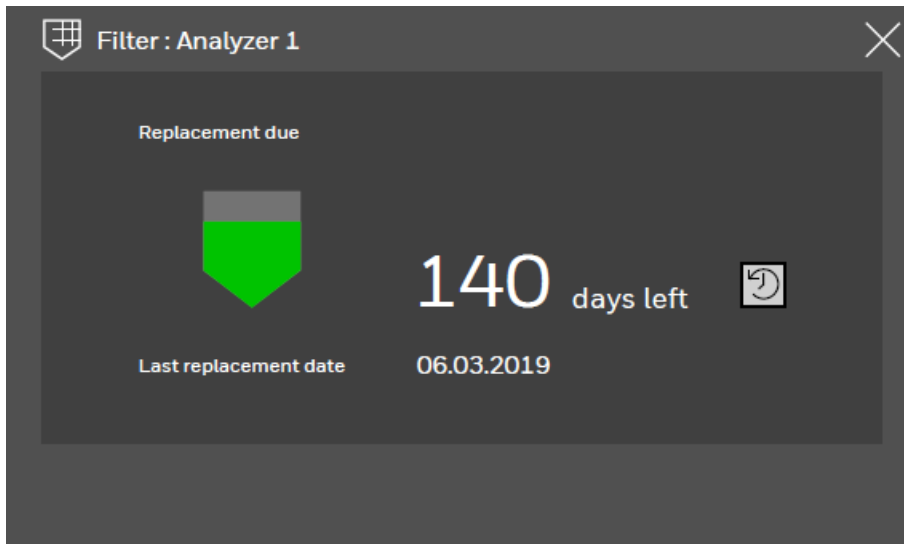

4. End of sample line filters should be replaced on a regular interval of 3 months
5. Tap the **Reset Count** button  to reset the replacement due days.

NOTE

This counter should be used with end of sample line filters only.

NOTE

Internal filters protecting the orifice should be inspected and cleaned on a regular interval of 6 months. See the See "Orifice Filter Inspection, Cleaning & Replacement " on page 150 for more information..

View and Export the Events History Listed By Time

1. In the left navigation panel, tap **Event History** 
2. Tap in the **Listed by time** tab. A list of all events is displayed.

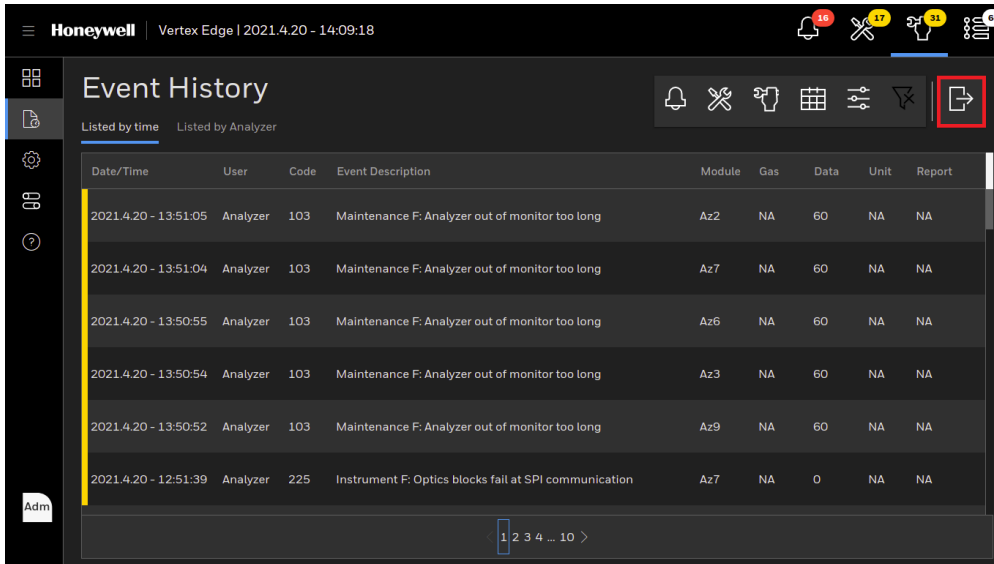

3. In the Listed by Time screen, you can filter the information.

Export the Events History

1. Insert a USB flash drive to Vertex Edge HMI PC.

2. Tap the Export icon  to export the event histories to CSV file.

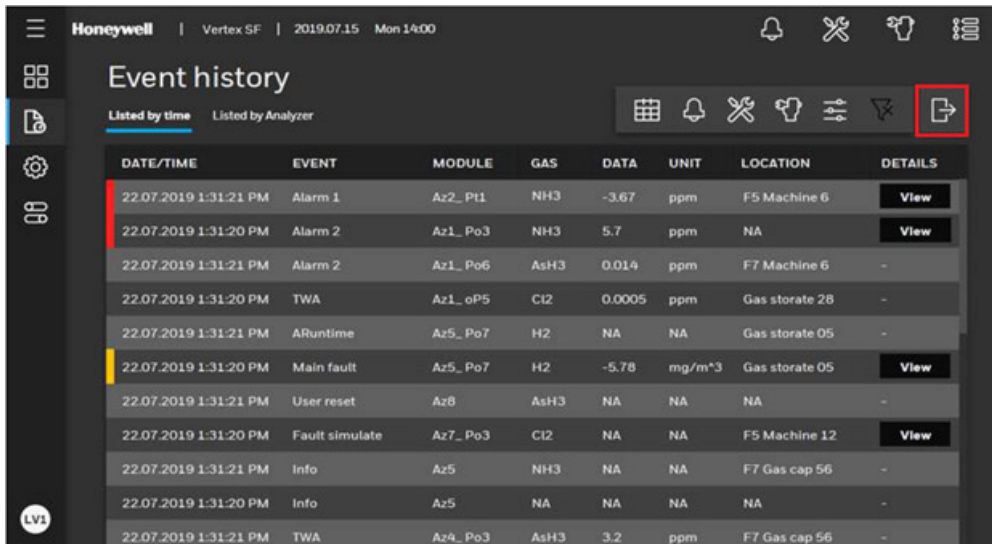

- Export event history screen will pop up asking the user to enter a file name. Type a file name and touch NEXT button.

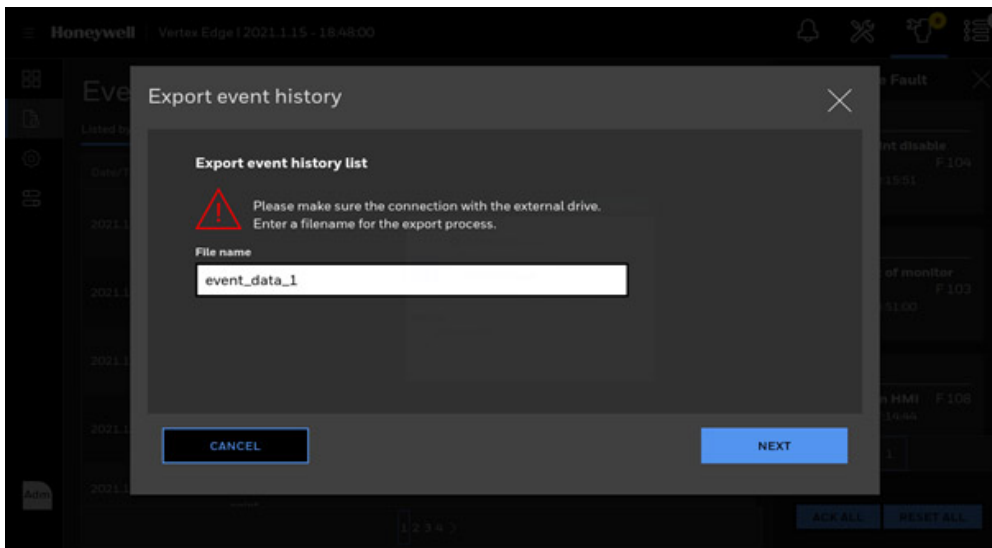

- Select a USB drive to export the event histories and touch NEXT button. Once exporting is complete, the "Exporting is completed" screen will be shown as below. It may take several minutes depending on number of events to be exported.

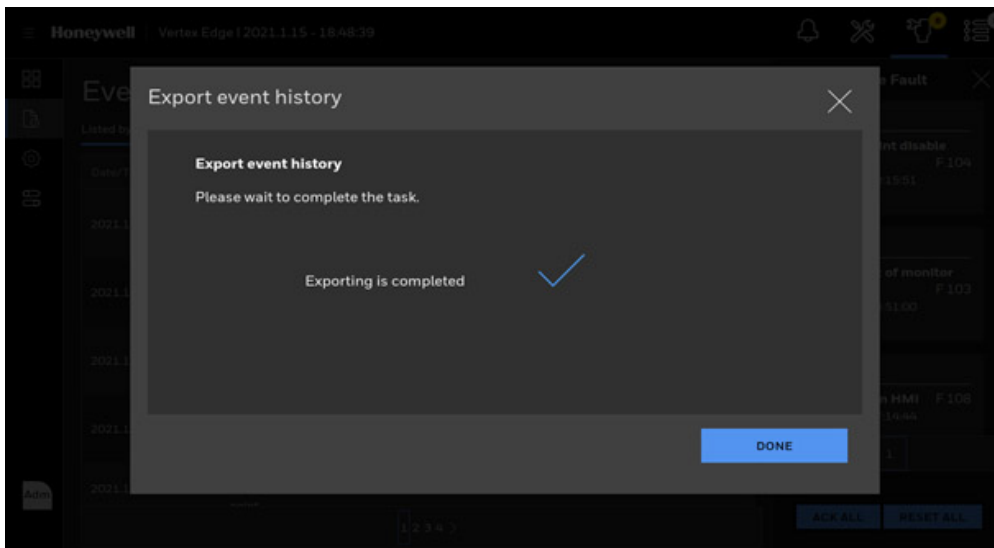
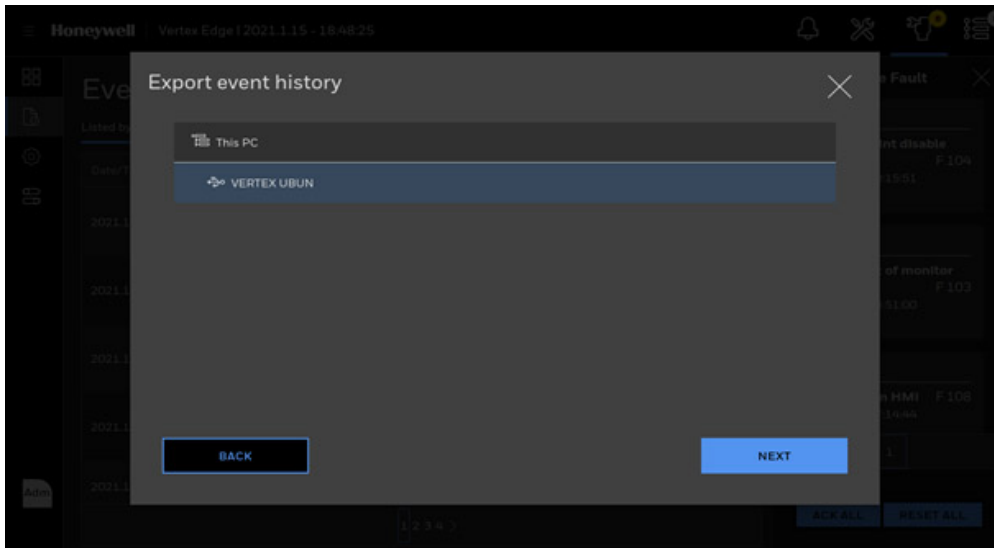

View and Export The Events History by Analyzer

1. In the left navigation panel, tap **Event History** 
2. Tap in the **Listed by Analyzer** tab. A list of all analyzer events is displayed.

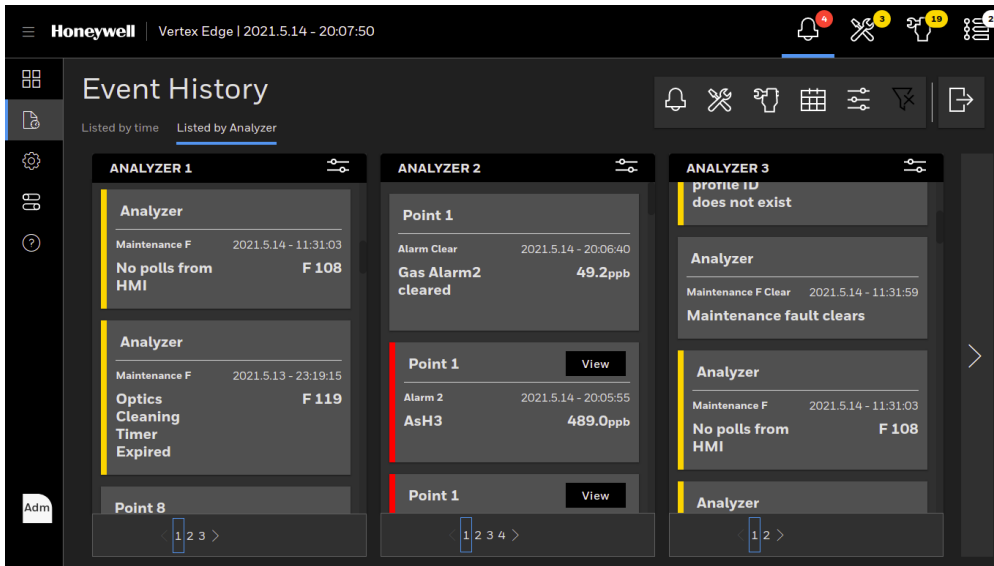

3. Tap on the **More Filters** button  to view the events of specific Points.

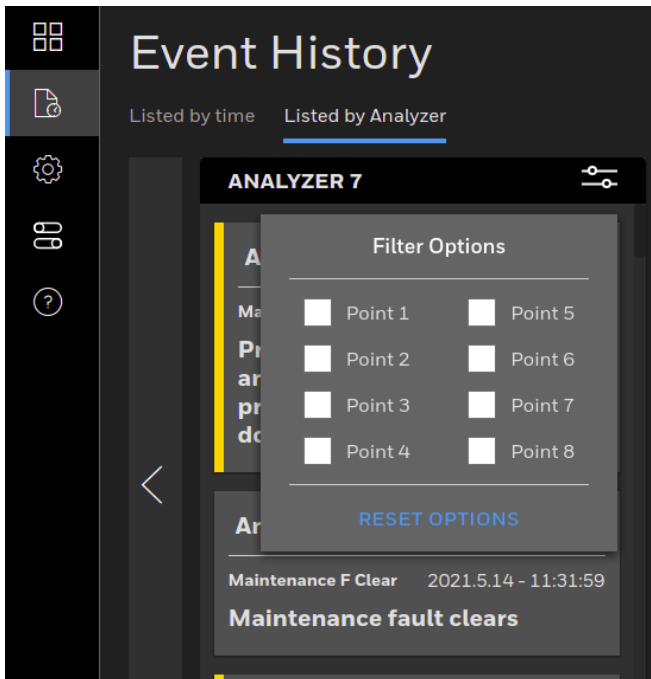

View Help File

1. In the left navigation panel, tap HELP 
2. Navigate the help using navigation panel on the top of help.

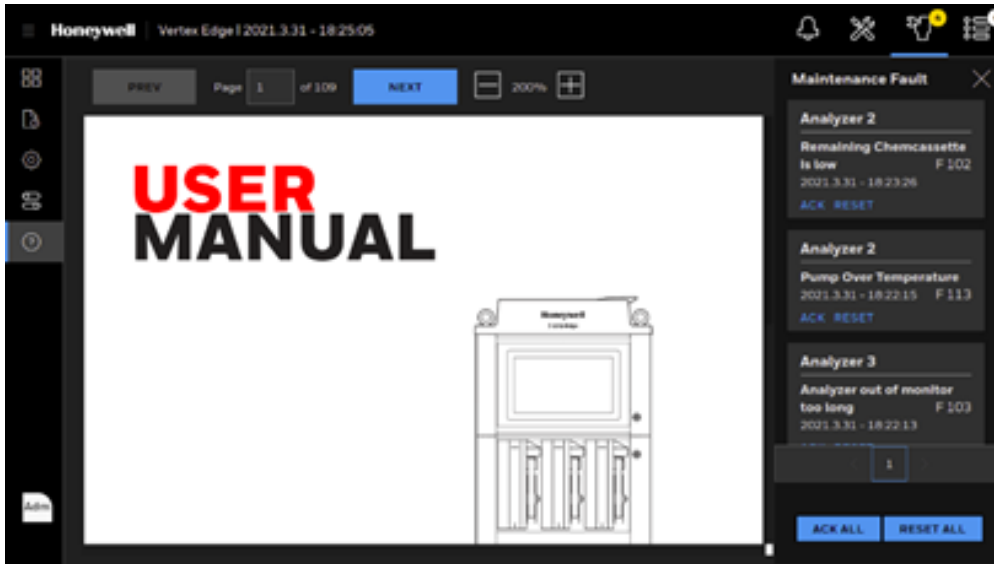

View System Version Information

Version Manager shows version information of Vertex Edge system components such as Analyzer, DAq and PDU. The version information includes FW version, HMI application version, part numbers, serial numbers and rack ID.

1. From the main menu, go to System Manager > Version Manager

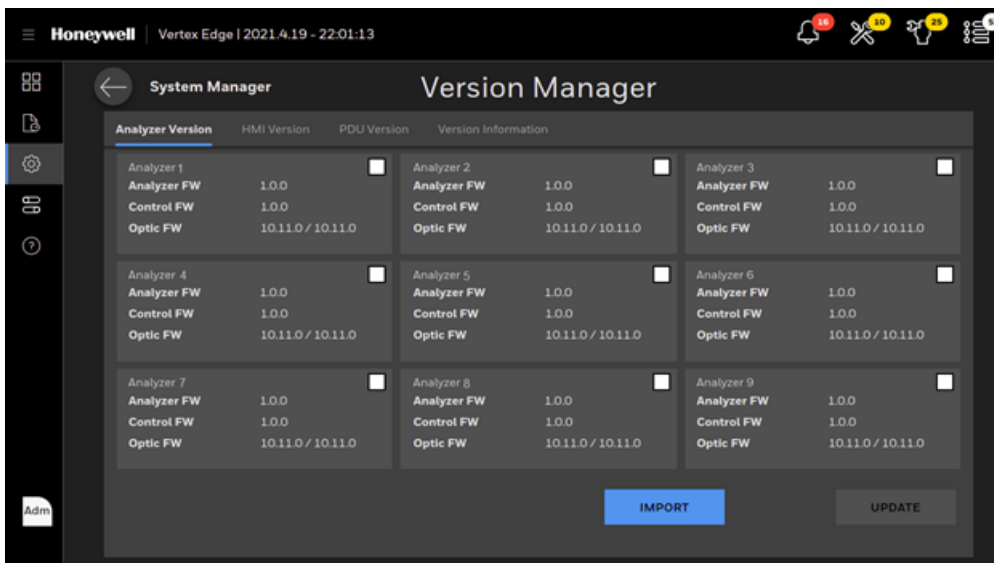

2. Tap on the HMI Version or PDU Version tab to view detailed version information of the system components.

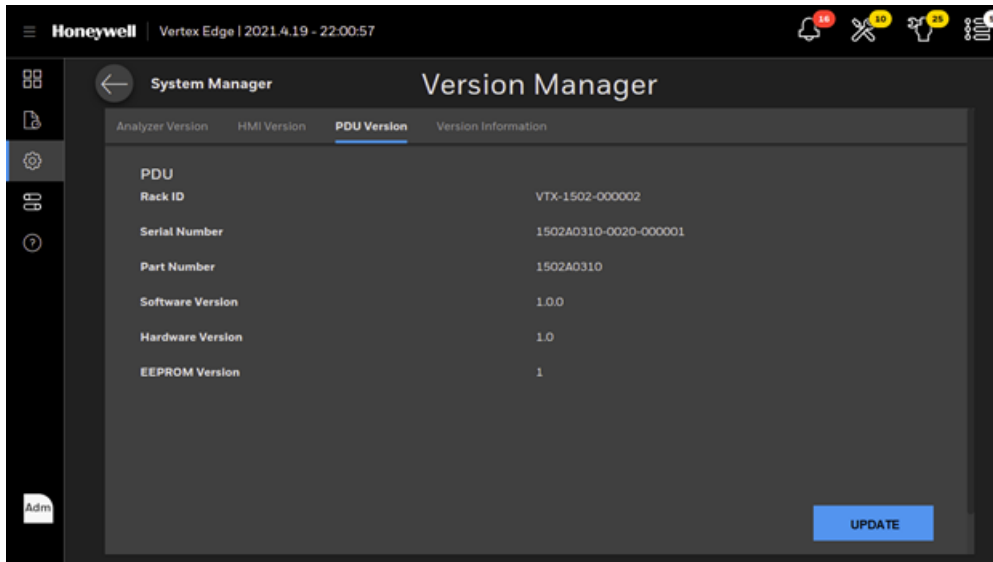

3. In Version Information tab, the summary of version information is shown and can be exported to a CSV file. Tap on the EXPORT button and enter file name to export a version summary.

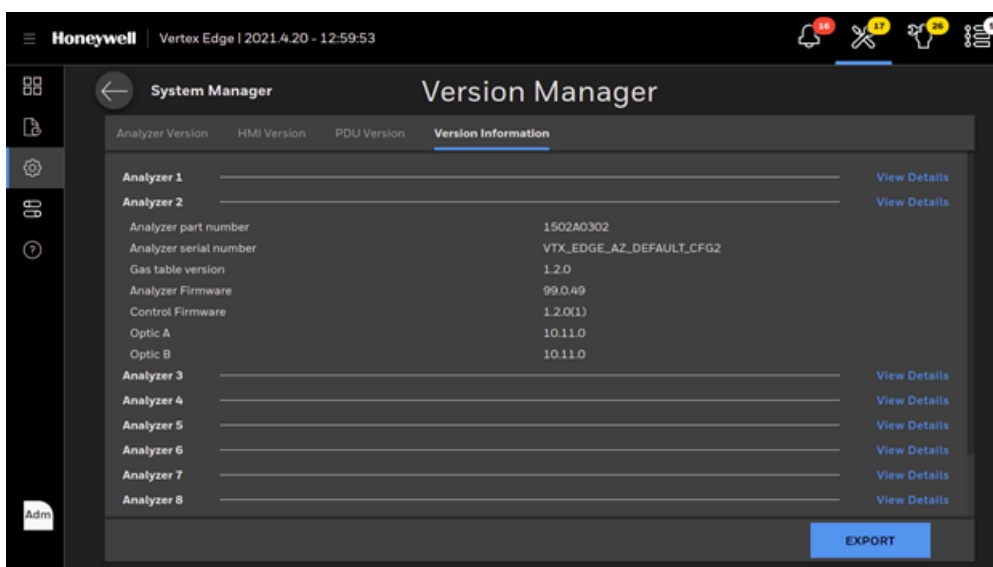

Update an Analyzer Firmware

To update an analyzer firmware, a USB flash drive with an update file should be prepared. Please contact Honeywell Analytics to get the latest update SW files.

NOTE

If using the USB 2.0 ports, the operator must be grounded.

1. From the main menu, go to System Manager > Version Manager
2. Insert the USB flash drive to any available USB port of the Vertex Edge HMI PC.



3. Tap on the IMPORT button to copy an update file from USB flash drive to HMI PC
4. Select an analyzer update file. If the selected update file is valid, HMI will import it successfully as below.

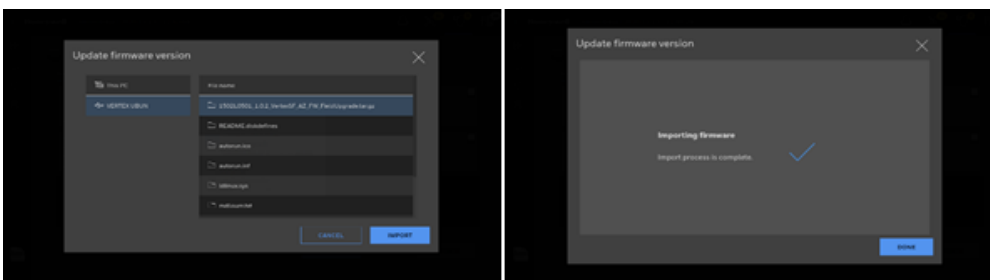

5. After importing the target update file, select the Analyzers to be updated and tap on "Update" button. A user will be asked to select the system type and a target firmware file in the list as below. The updatable firmware is as below.
 - Analyzer firmware
 - Control firmware
 - Optic firmware.

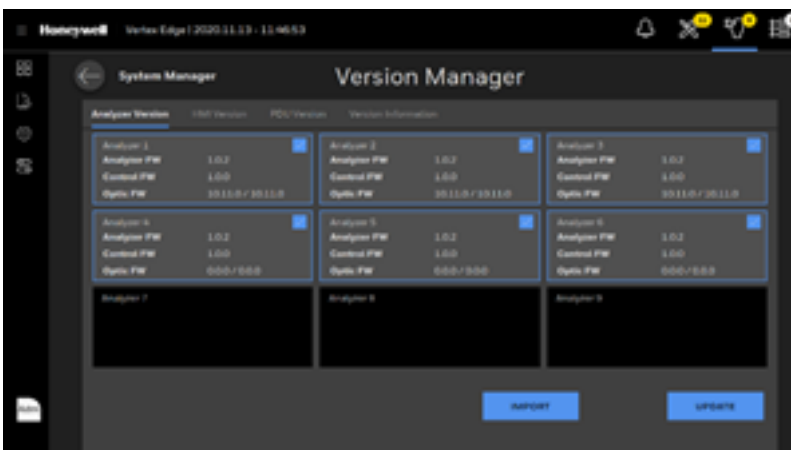

6. Tap on the "Next" button. The "Stop monitoring" screen will pop up asking a user to confirm it.

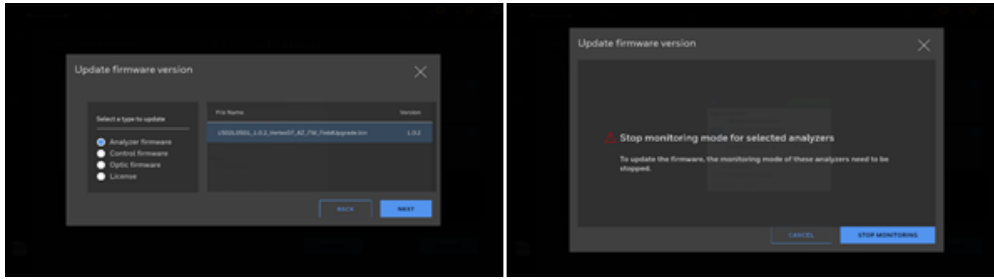

- Tap on “Stop Monitoring” button and firmware update will be started. The firmware update status will be shown using two green dots. The first green dot indicates that the update file is transferred to Analyzer and the second green dot means that the firmware updated successfully. If there is any communication error or any issue in updating the firmware, the red dot will be shown instead.

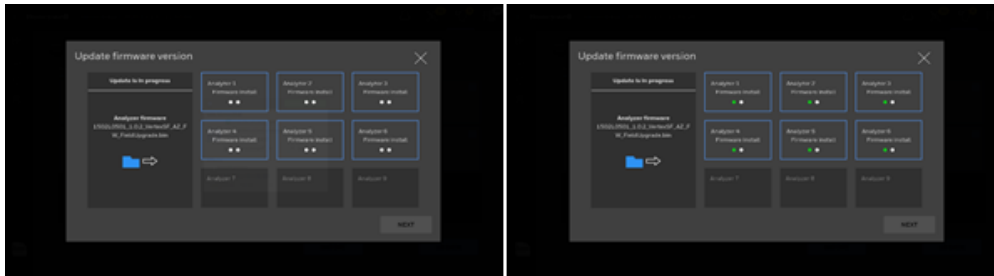

- Tap on “Next” button when FW update is done with two green dots and it moves back to Version Manager screen with updated version information.

Update an HMI Software

To update an HMI software, a USB flash drive with an HMI update file should be prepared. Please contact Honeywell Analytics to get the latest update HMI SW file.

- From the main menu, go to System Manager > Version Manager and Tap on HMI Version
- Insert the USB flash drive to any available USB port of the Vertex Edge HMI PC.
- Tap on the UPDATE button and select the HMI update file (*.tar.gz) from the USB flash drive.

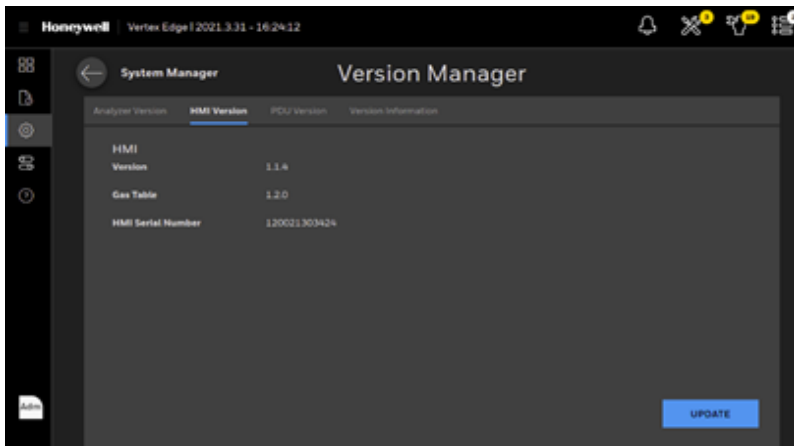

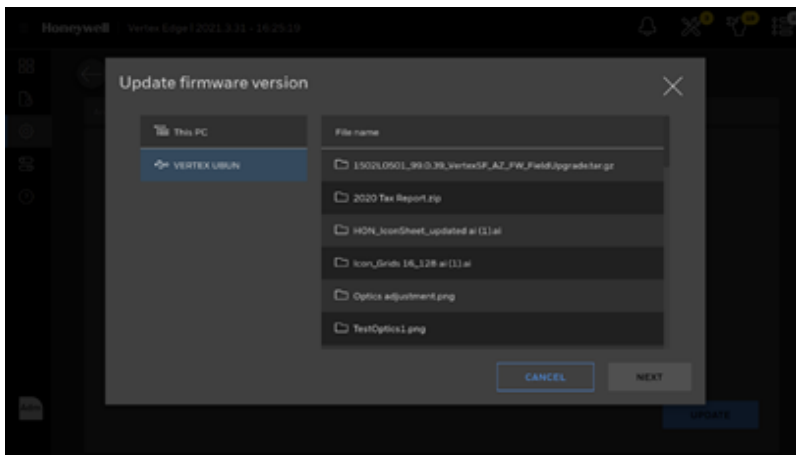
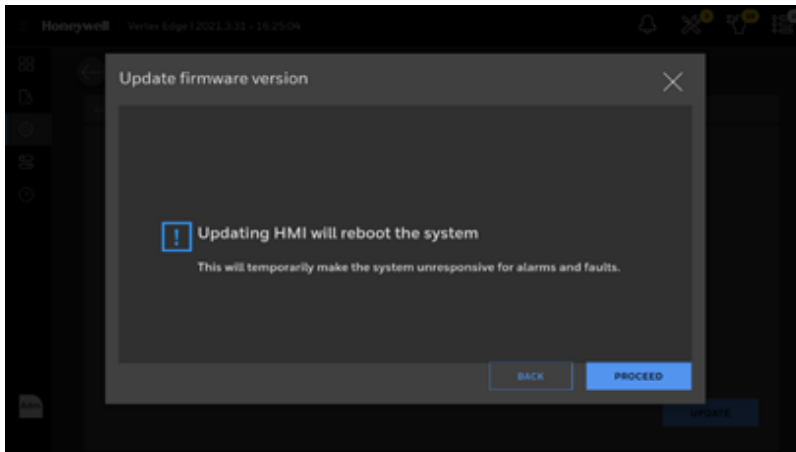

4. The estimated time to update an HMI software varies depending on what software components are updated. Wait until HMI software update is done and HMI software restarts.

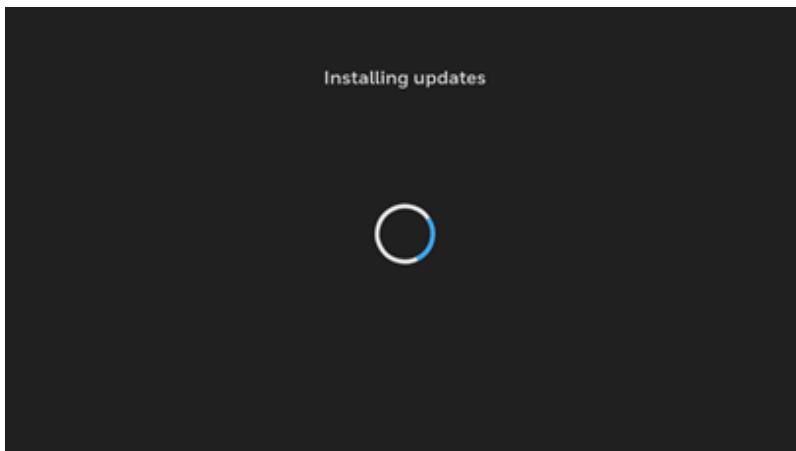

NOTE
 While updating an HMI software, the Analyzers may generate a maintenance fault of no polls from HMI (F108).

Activate Optional Function

To activate an optional function, an appropriate license file is required. Please contact Honeywell Analytics to get the license file.

1. From the main menu, go to System Manager > Version Manager
2. Tap on the Import button to import the license file from a USB flash drive.
3. Select an appropriate license file and tap on the IMPORT button.
4. Once the license file is imported, select the analyzers where the license is applied.
5. Tap on the UPDATE button, select a type as License and the license file in the list, and tap on the NEXT button.

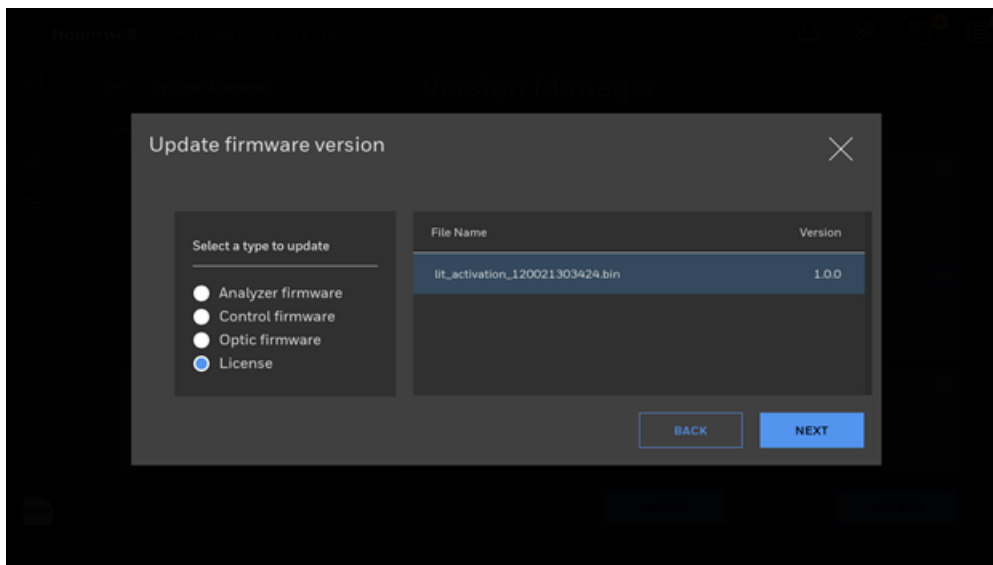

System Shutdown



CAUTION

Failure to properly shut down the Vertex Edge could result in system file corruption.

1. Go to Runtime Operation and stop monitoring mode for all analyzers.

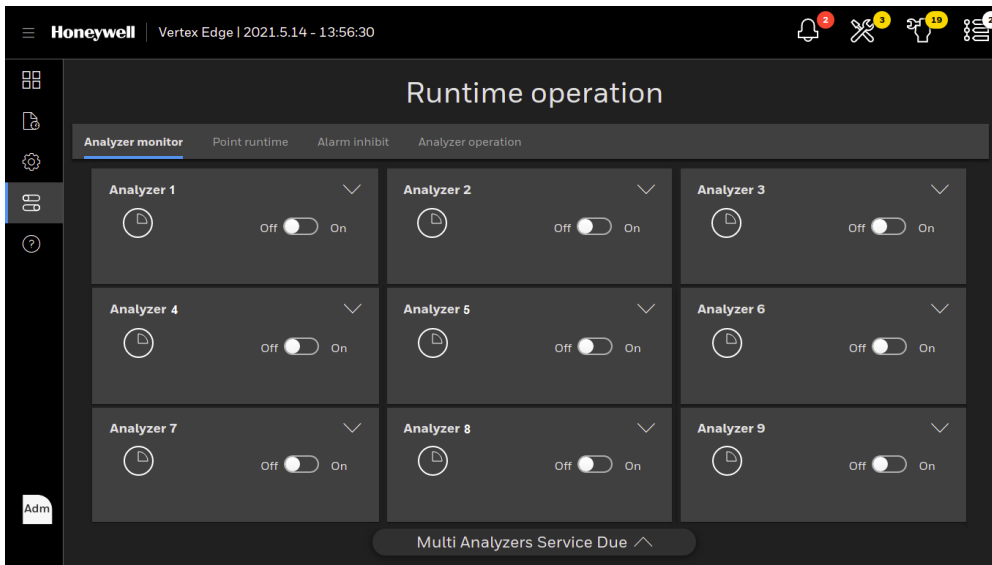

2. Go to Settings->System Switch and touch System Shutdown
Touch Proceed on the confirmation screen

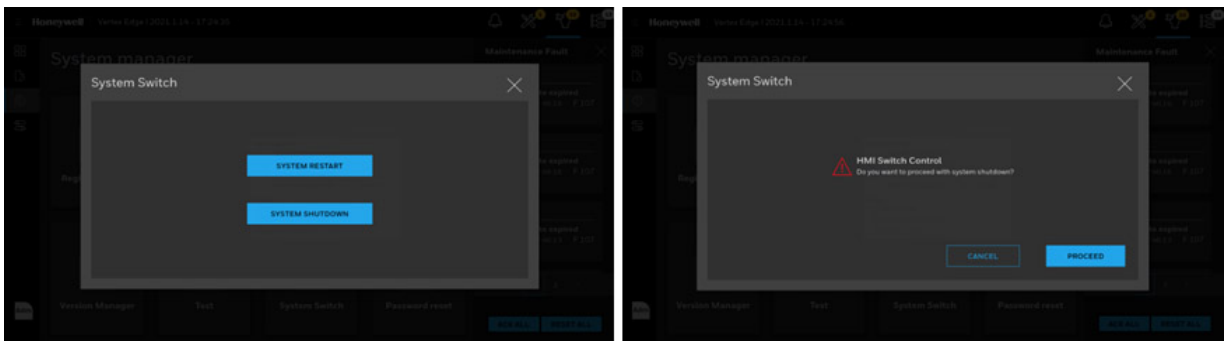

3. Set all analyzer switches (2) on PDU to "Off"
4. Once all analyzers are off, set the rack power switch (1) to "Off"



1) Main power ON/OFF switch

2) Analyzer power switches

Line Integrity Test (LIT)

Vertex Edge offers the optional capability to detect leaks in the sample line through the line integrity test (LIT). Analyzers equipped with the option detect a pneumatic signal from the valves installed at the end of the sample line. Any change in the signal will indicate a leak has been detected.



NOTE

This image has the LIT check valve assembly installed with the end of line filter.

Quantitative Performance

The pressure at the pump inlet must be less than -7.0 inHg or the test will be inhibited. The sample line must be 4.8 mm ID [thin wall or 0.190-inch ID] and have a length of 50 feet to 300 feet.

The total point flow (transport plus sample) is typically 2.2 liters per minute per point. This results in a differential pressure of about 1.7 inHg with the maximum tubing length. The check valve increases the differential pressure by an additional 2.3 inHg for a total of about 4.0 inHg.

During characterization the differential pressure must be 1.7 inHg or more or a fault will be issued. During LI testing the differential pressure must be at least 75% of the characterization differential pressure or more or a fault will be issued. Leaks of 1 mm [0.039 inch] diameter or larger will cause a substantial decrease in the differential pressure and the generation of a fault.

The LIT measurement requires that the total pressure variance of the sampled point, the Vertex rack, and the exhaust outlet must be less than 0.3 inHg. for correct operation.

Configure Line Integrity Test

1. From the main menu, go to System Manager > Profile Manager
2. To schedule an LIT (Line Integrity Test), select the Service Due tab and enable at least one of optional line integrity times (TWA time1 to TWA time3).

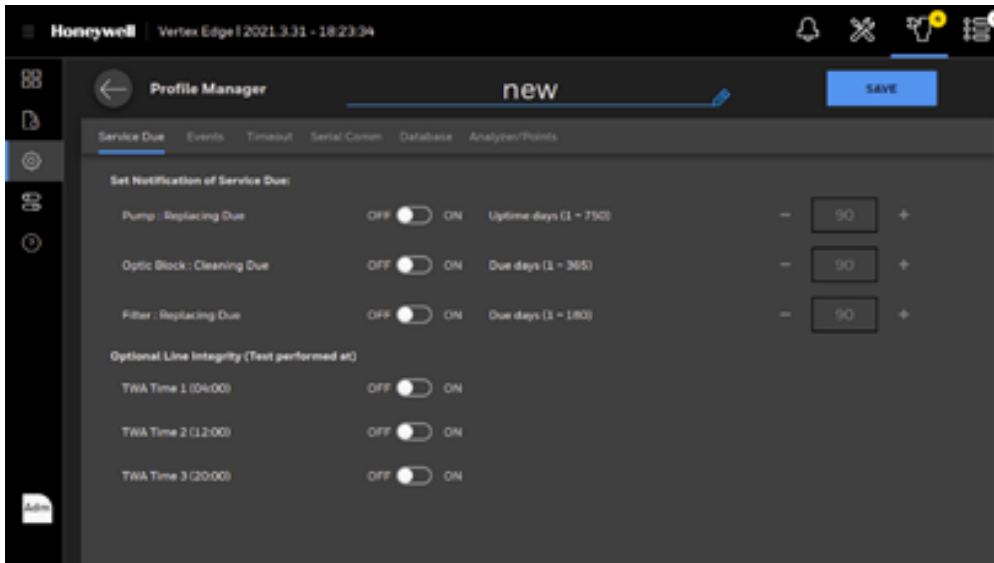

3. Go to Analyzer/Point tab and enable the Optional Line Integrity Test for the points where LIT is required.

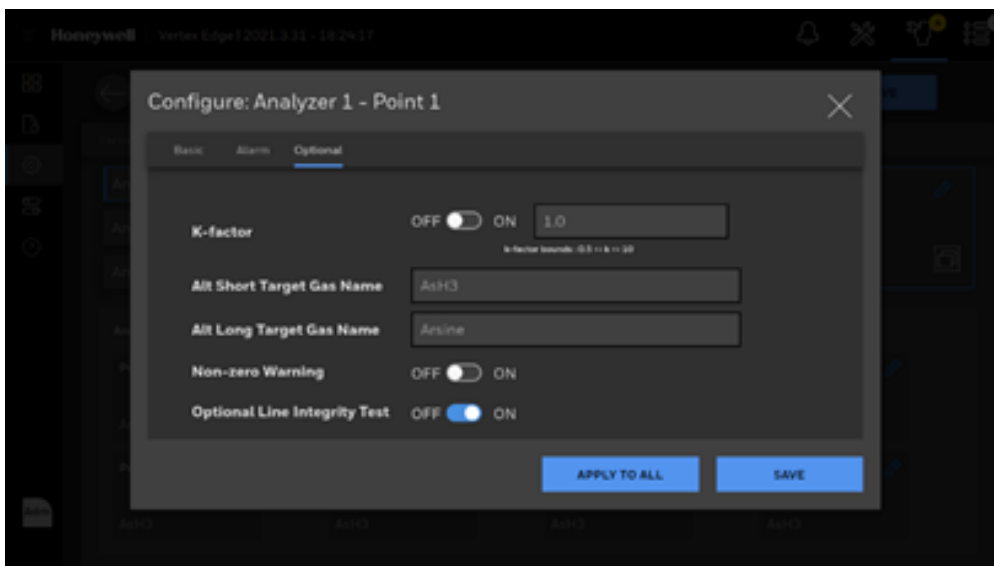

NOTE

LIT can be scheduled and performed when LIT option is purchased and activated on the Analyzers. Please contact Honeywell Analytics to purchase and activate an LIT option.

Characterize Line integrity Test

Line characterization is required when the LIT feature is enabled for the first time and for any component changes (e.g. sample line, check valve, internal tubing, etc.), with the exception of external filters. If unsure, please contact Honeywell Analytics. For continued safe gas detection, Honeywell also recommends replacing check valves every 5 years.

To characterize LIT:

1. From the main menu, go to System Manager > Test and tap on the Line Integrity Test.
2. The Analyzers with LIT option activated and LIT enabled for at least one point will be shown in the Line Integrity Test screen. If any analyzers with LIT option activated are not shown, check Analyzer/Point configurations by referring to Configure Line Integrity Test.
3. To characterize the external sample lines, tap on the Record Known Good LITC button and confirm the stopping of monitoring mode.

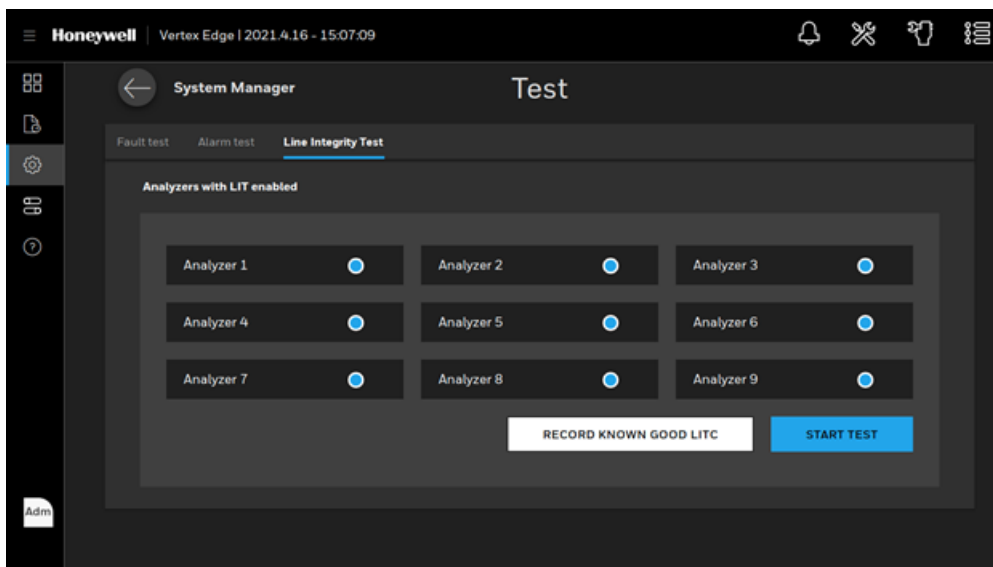

NOTE

Characterization should be performed when the tubes are known to be leak-free and otherwise correct. It is possible to confirm that a tube is leak-free by plugging the end and observing the sample flow decrease to zero.

Performing Line Integrity Test

1. From the main menu, go to System Manager > Test and tap on the Line Integrity Test.
2. The Analyzers with LIT option activated and LIT enabled for at least one point will be shown in the Line Integrity Test screen. If any analyzers with LIT option activated are not shown, check Analyzer/Point configurations by referring to Configure Line Integrity Test.
3. To perform an LIT manually, tap on the START Test button and confirm the stopping of monitoring mode.

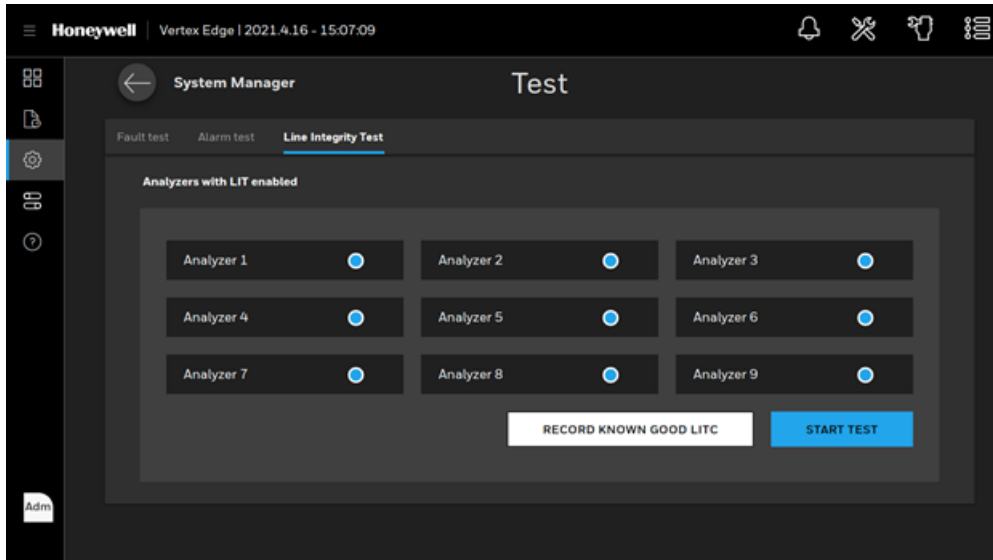

NOTE

Check whether check valves are plugged in at the end of the sample lines prior to starting an LIT.

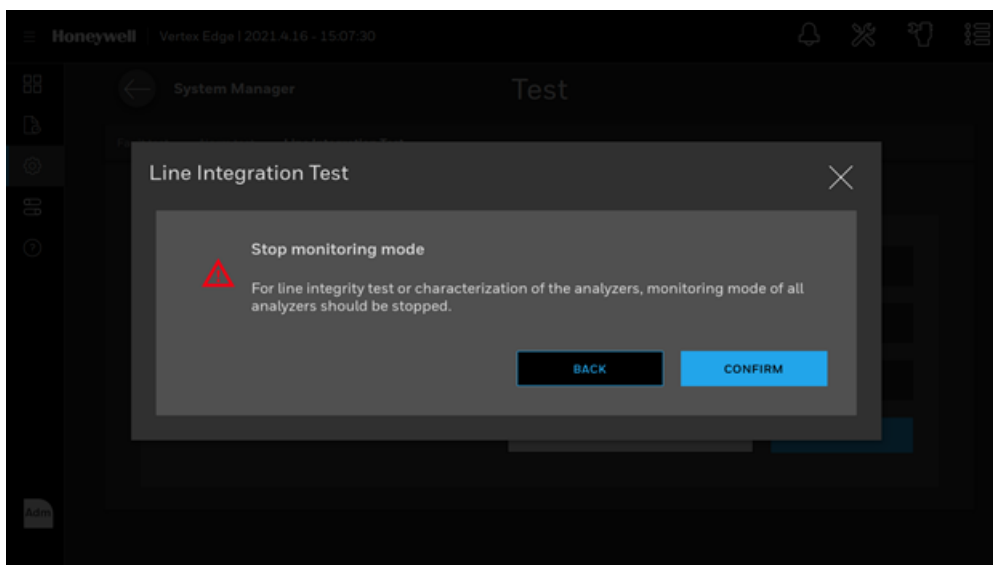

4. Line Integrity Test will be performed automatically by turning off and on the pump. Please follow the instructions on the screen.

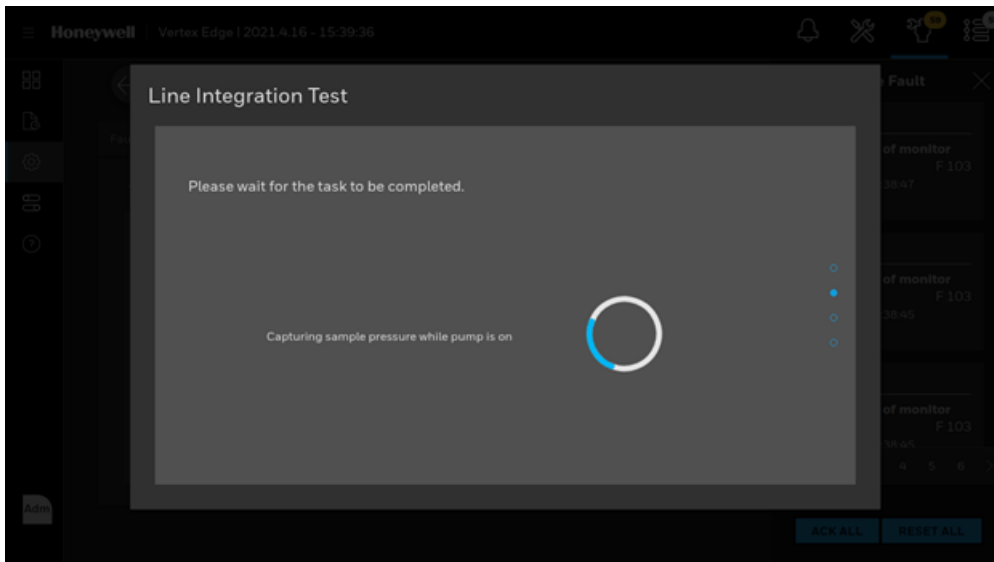
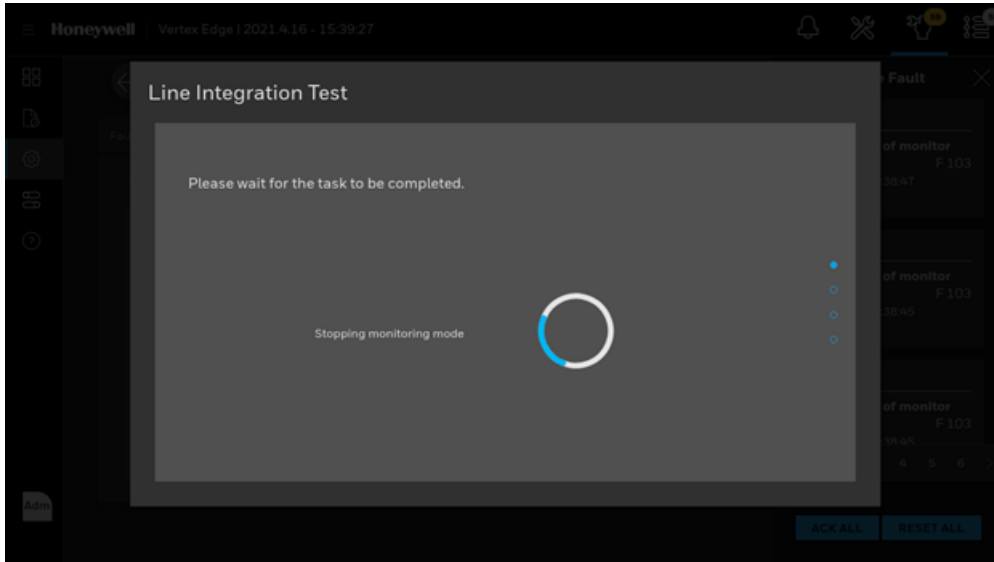

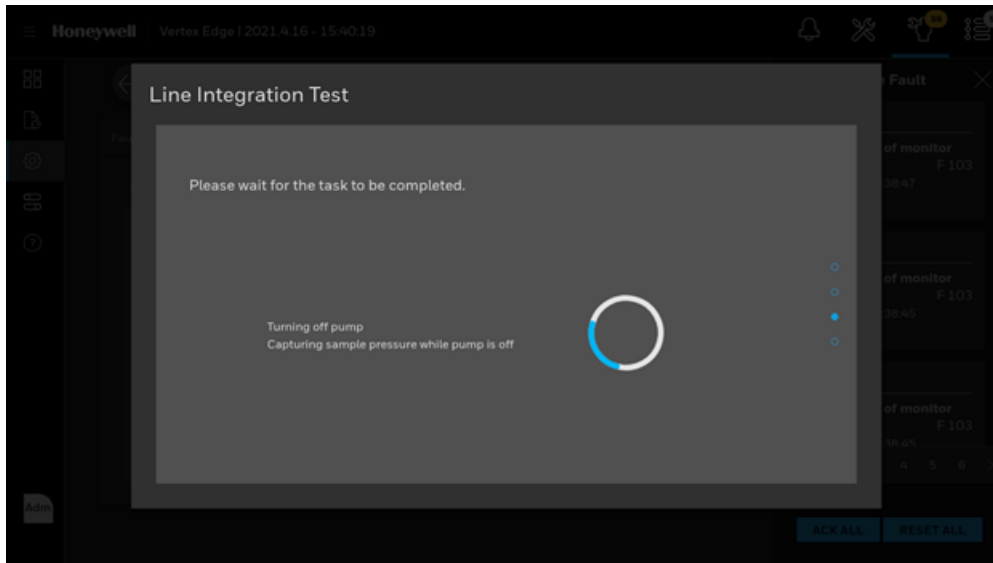

5. At the last step of line integrity test, the analyzers will resume monitoring mode.

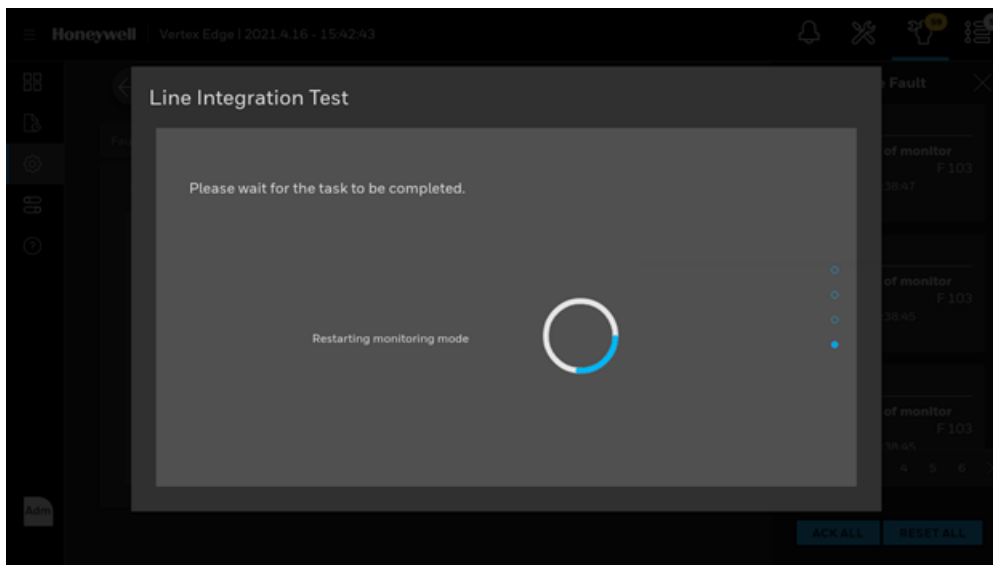

6. After restarting monitoring mode, an LIT result will be shown as below. The vacuum level and point pressure will be shown with test result. The points in green indicate a success of LIT while points in red detect leakage in the sample line.

Honeywell | Vertex Edge | 2021.4.16 - 15:09:26

System Manager Test

Fault test Alarm test **Line Integration Test**

Analyzer 1	-10.072 in Hg	Analyzer 2	-10.096 in Hg	Analyzer 3	-9.968 in Hg						
-1.263	-1.270	-1.189	-1.296	-1.089	-1.042	-1.151	-1.120	-1.175	-1.120	-1.089	-1.089
-1.332	-1.248	-1.245	-1.311	-1.089	-1.135	-1.049	-1.120	-1.159	-1.120	-1.143	-1.120
Analyzer 4	-10.048 in Hg	Analyzer 5	-10.080 in Hg	Analyzer 6	-10.088 in Hg						
-1.145	-1.075	-1.118	-1.094	-2.640	-2.560	-2.630	-2.735	-2.640	-2.560	-2.630	-2.735
-1.131	-1.123	-1.114	-1.066	-2.640	-2.560	-2.630	-2.735	-2.640	-2.560	-2.630	-2.735
Analyzer 7	-10.112 in Hg	Analyzer 8	-10.055 in Hg	Analyzer 9	-10.096 in Hg						
-0.543	-1.222	-1.287	-1.259	-1.132	-1.233	-1.111	-1.136	-2.640	-2.560	-2.630	-2.735
-1.244	-1.251	-1.281	-1.247	-1.145	-1.152	-1.146	-1.139	-2.640	-2.560	-2.630	-2.735

Adm

NEXT

5 Maintenance

This section describes routine maintenance procedures.

Maintenance Schedule

Component	Frequency
Sample line filters (end of line)	3-months
Teflon Corrosive Filter Membrane (end of line)	1 month
Teflon Corrosive Filter	3 months
Pump vane replacement	9-24 months operation per pump
Pump stem and o-ring	6 months
Valve filter	1 year
Supply Vacuum Filters	3-6 months
Alternate Pumps	6 months
Optics Cleaning	1 year or as needed
System File Maintenance	1 year or as needed
LIT Check Valve	5 years
Orifice Filter	3-6 months

Replace an Analyzer

The Vertex Edge rack is designed for quick replacement of major components. You may replace the Chemcassette analyzer while other analyzers continue to monitor.



WARNING: Do not connect or disconnect anything from the Power Distribution Unit (PDU) while energized.

1. Turn off monitoring mode for the Analyzer to be replaced. In the left navigation panel, tap **Runtime Control**



2. Tap on the **Analyzer Monitor** tab.

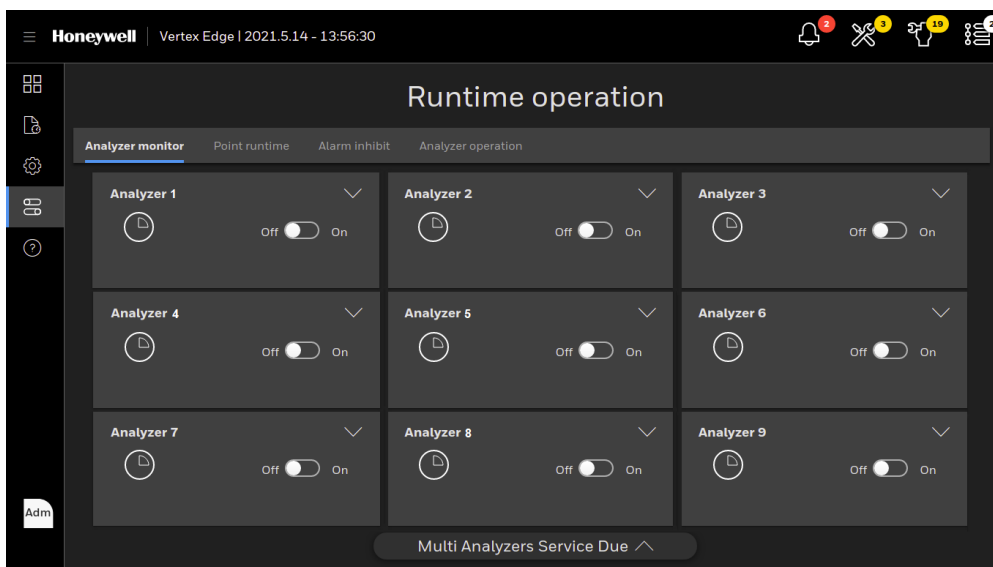

3. In Runtime Operation, tap on the **Analyzer operation** tab.
4. Tap **Release** and pull out the analyzer as far as possible

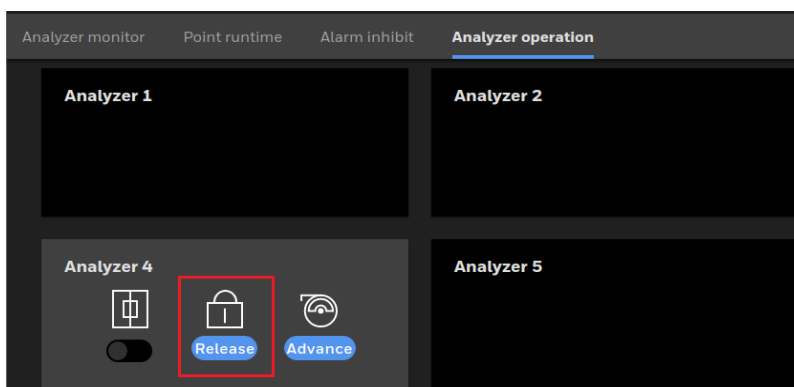

5. Tap the open the gate command if you wish to remove the Chemcassette. After removing the Chemcassette put the optics protection cards in each optic block.
6. Close the gate.

7. Turn off power to the analyzer by switching the analyzer power OFF on the corresponding switch on the PDU
8. Unscrew the two screws located at the top and bottom of the manifold bracket.



9. Remove the tubing harness (2) carefully and remove internal Ethernet cable (1) and power connector (3) from the Analyzer.

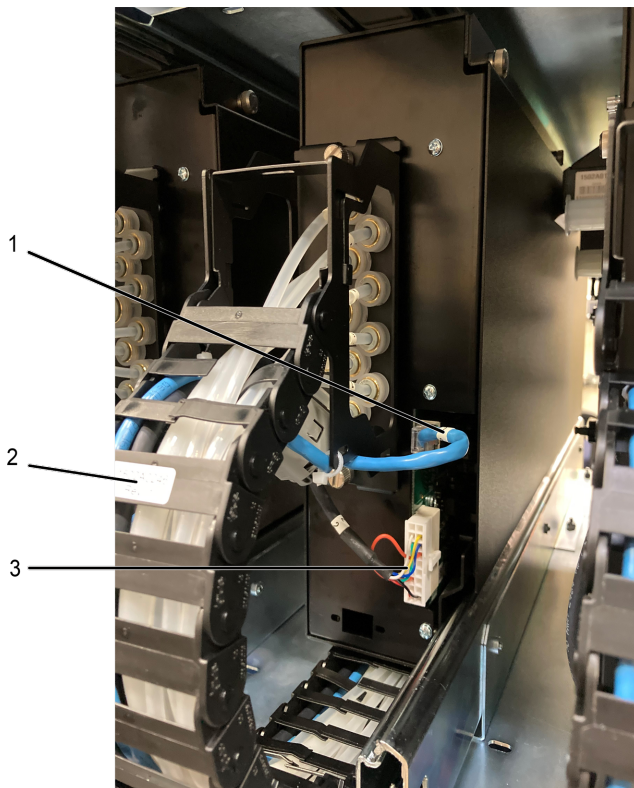

10. Unlock the latch on the top of the Analyzer (as shown) and pull out.

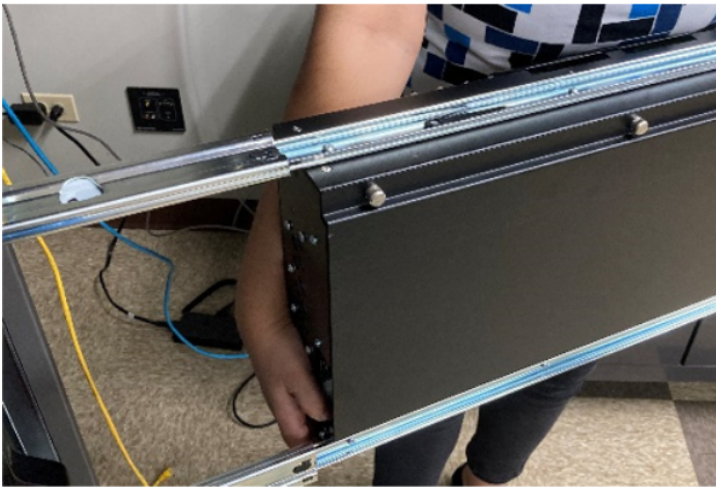
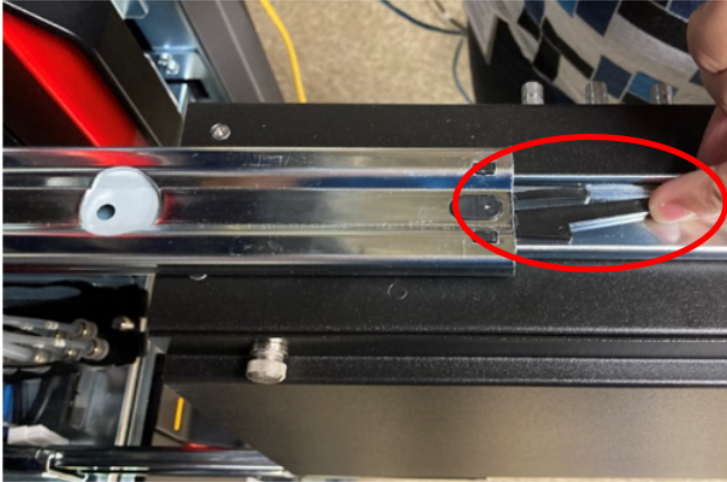

11. After removing the Analyzer, make sure exhaust port of the analyzer be blocked with plug as shown in the picture below.



NOTE

Failure to block the analyzer exhaust port will impact the flow system for the running unit.

Install an Analyzer



WARNING: Do not connect or disconnect anything from the Power Distribution Unit (PDU) while energized.

1. Turn analyzer power switch off at the PDU.
2. Reach into the slot and position cables out of the way.
3. Place analyzer on slides. Push in until locks engage.

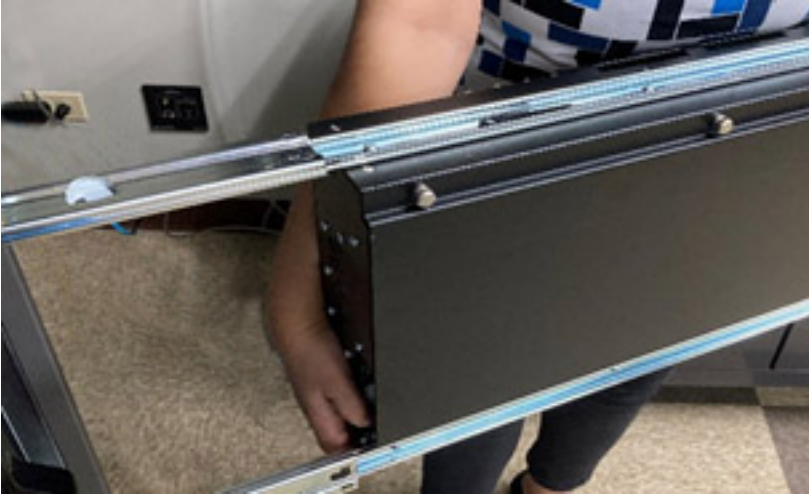

4. Slide Analyzer out until fully extended.
5. Reach behind the analyzer; connect the tubing harness.

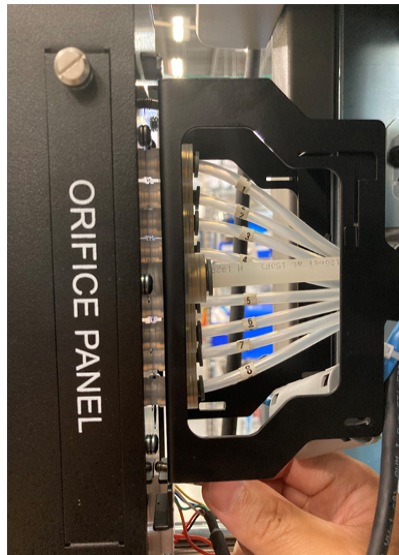
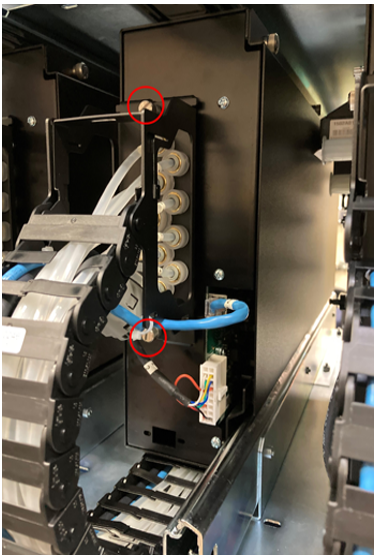

IMPORTANT: The 2 screws need to be tightened to fully secure. If these are not tightened, the unit will leak.

6. Connect the Analyzer internal Ethernet cable (1) and power connector (3) from the Analyzer.

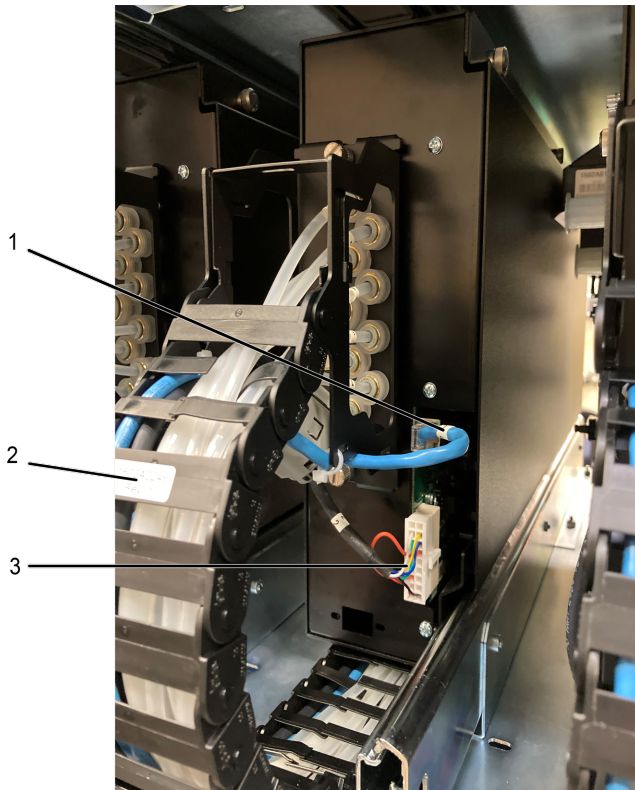

7. Carefully push analyzer partially into the cabinet and then pull out to verify all cables move freely and the slides lock. Repeat in and out action to loosen slide. Push analyzer into cabinet.

Return to Service

1. Turn analyzer power switch on.
2. Re-install the Configuration Profile.
3. Install the Chemcassette.
4. Return analyzer to monitor mode in Runtime Options Menu.

Replace a Pump

The Vertex Edge System includes two vacuum pumps. One pump operates while the other is idle. You may replace a defective pump while the other pump continues to operate.

NOTE

You may replace a pump only when the system places it in off condition. Do not replace an operating pump.



WARNING

The pump to be disconnected must be off

1. Unscrew 2 screws securing the fan door



2. Open the fan door to the fully out of the way of the pump drawer

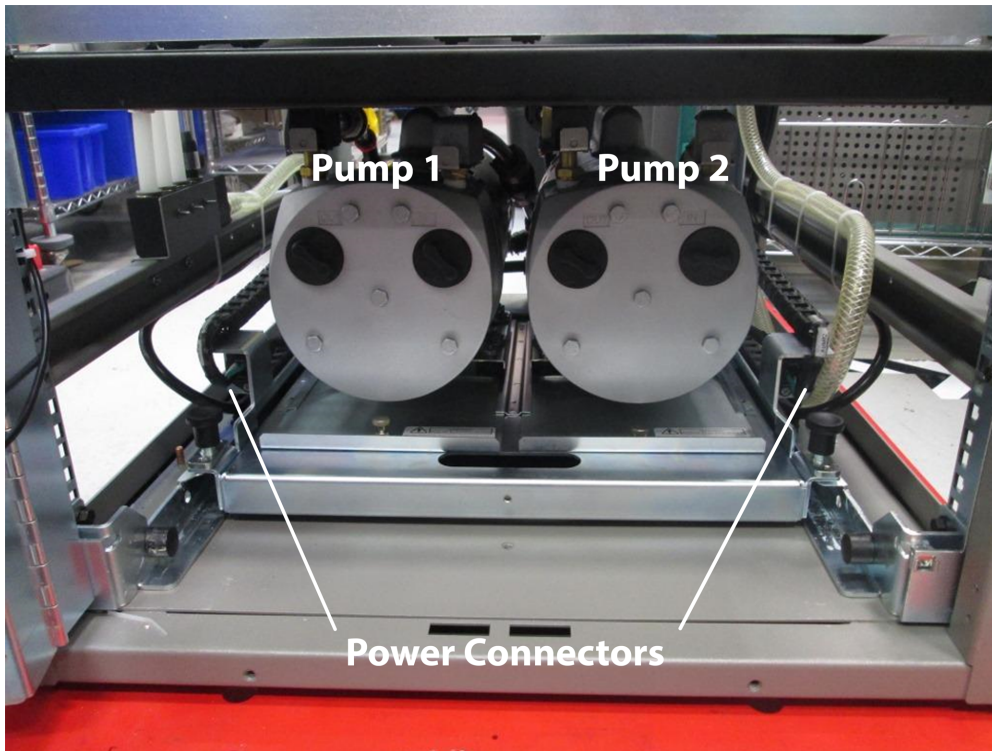

3. If replacing Pump 1, disconnect the power connector before opening drawer. (Pump 2 power connector can be removed with the drawer opened). Power connector removal are in steps 4-5.
4. Uninstall the electrical connector on the side of the pump
 - a. Pull the white tab out
 - b. Push down on the black tab and pull back on the connector

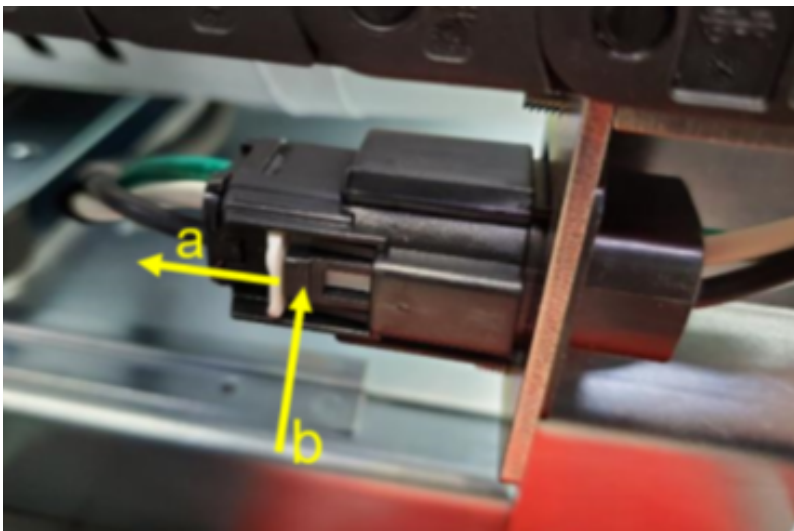

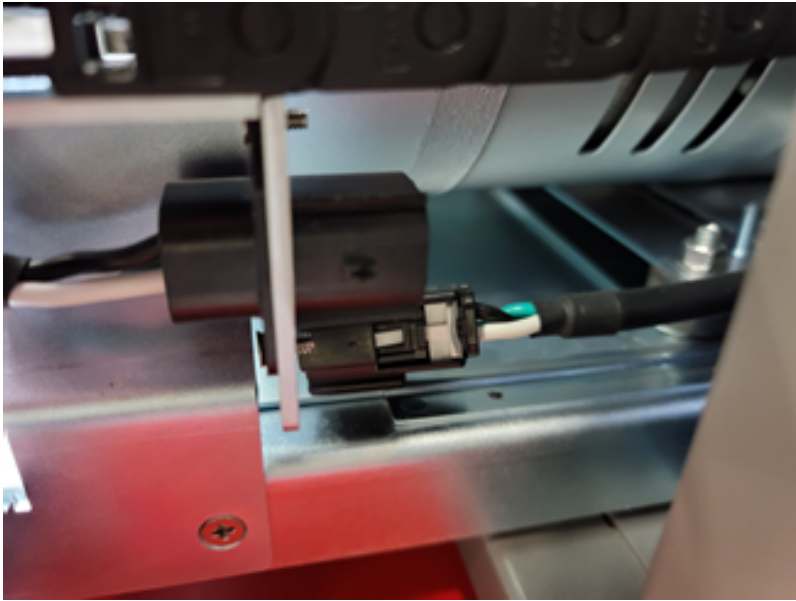

5. Once pump cable is disconnected, tuck it under the pump head on the pump plate

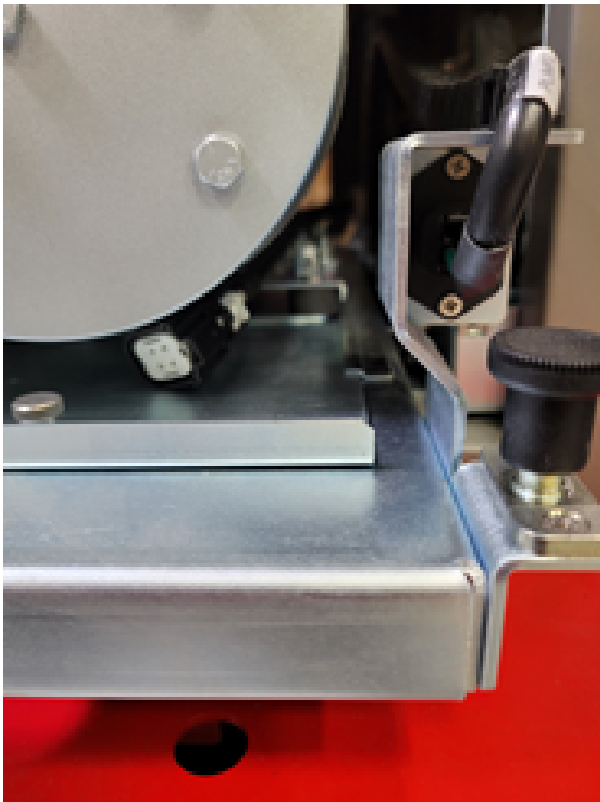

6. To open the pump drawer, pull up on the two knobs securing the pump bed and twist to unlock them.

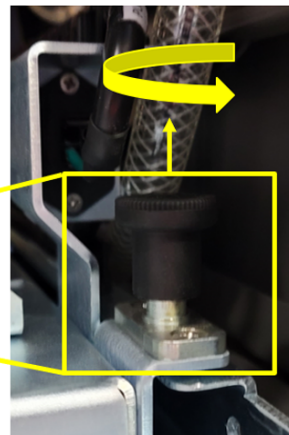
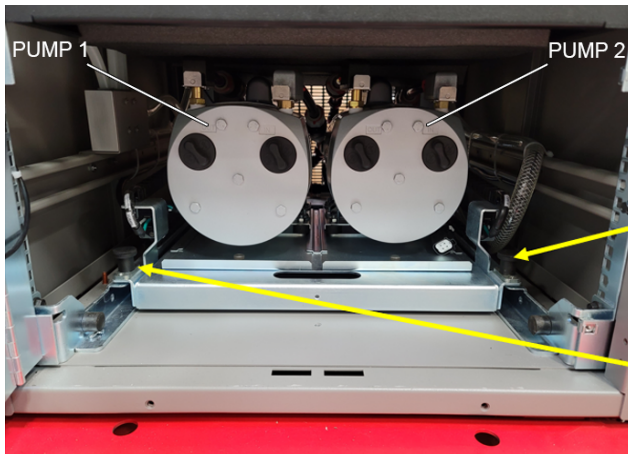

7. Grab the handle and pull the pump drawer out

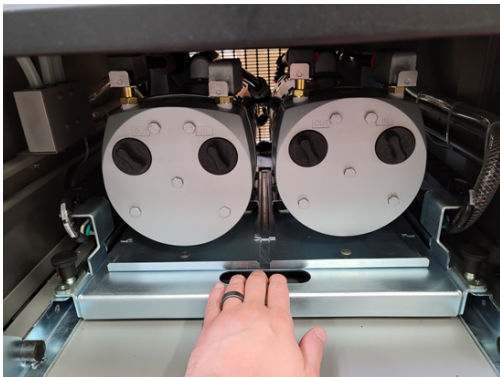

8. If replacing Pump 2, disconnect the power connector as covered in steps 4-5.
9. The pump fittings are removed by pushing in on the silver plate and pulling up on the fitting at the same time

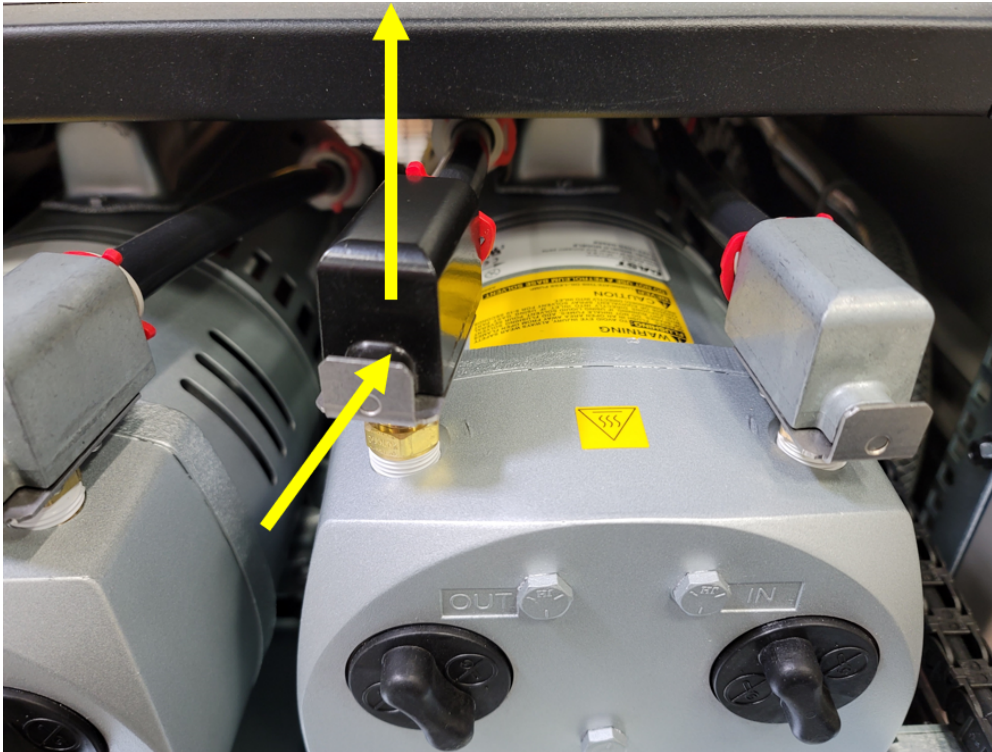

10. Disconnect the vacuum side (silver fitting)
11. Disconnect the exhaust side (black fitting)
12. Once disconnected the fittings can be placed to the side or on top of the pump



13. With the power connector removed and the vacuum and exhaust tubing connections removed, push the drawer back to the locked position. (This will prevent the drawer from moving while swapping out the pump)
14. Pull up on the locking pin holding the pump plate in place

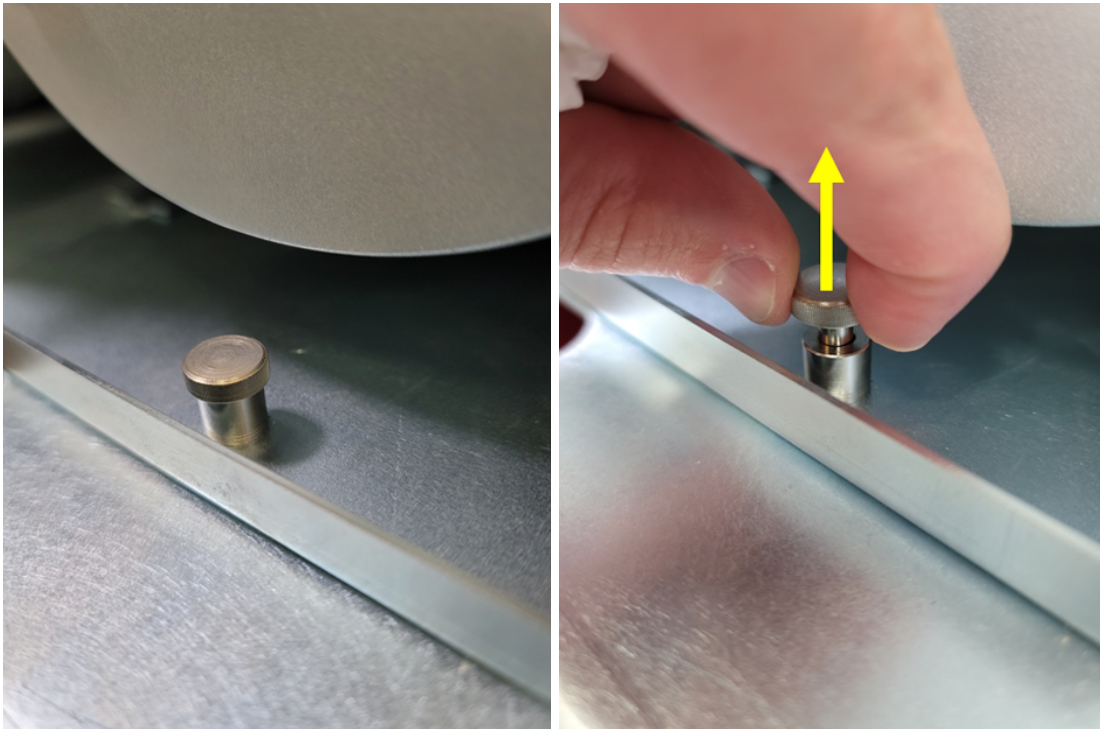

15. While the locking pin is pulled up, pull back on the pump plate to remove the pump
(Note: The picture shown has the pump drawer opened and unlocked. This orientation is to show the pump pin and plate. This step should be performed in the locked position. The locked position will prevent the drawer from moving while swapping out the pump.)



16. Once the pump has been removed, a new pump can be installed in its place
(Note: the picture shown has the pump drawer opened and unlocked. This is to show the pump drawer with pump 2 removed. This step should be performed in the locked position. The locked position will prevent the drawer from moving while swapping out the pump.)

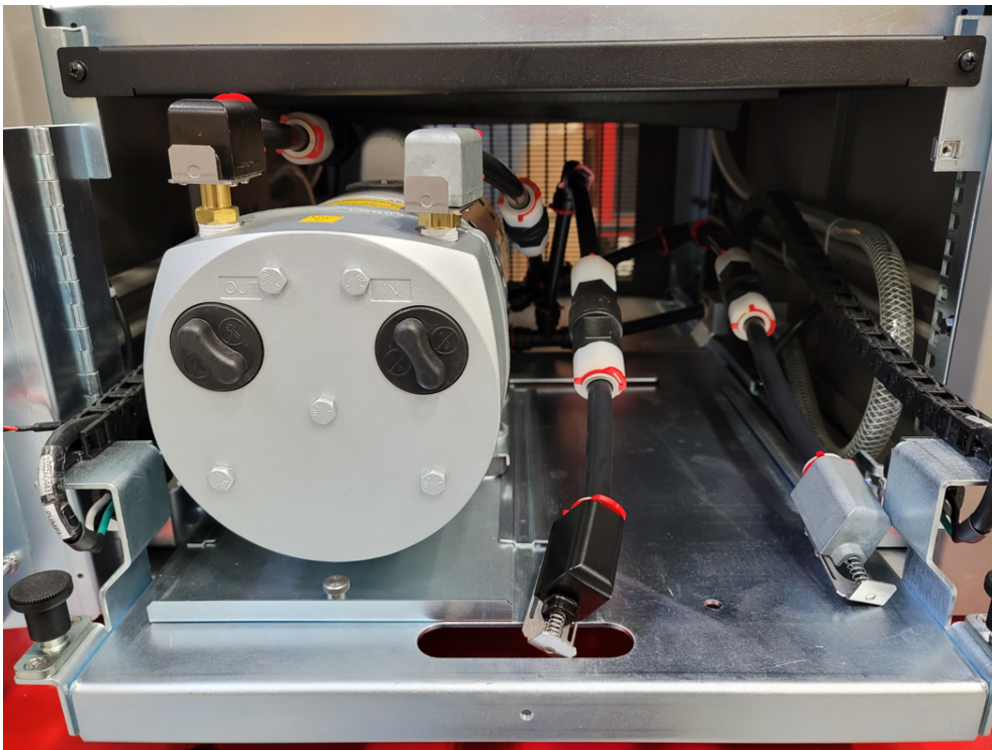

17. Lift up the tubes and connectors, then slide in a new pump assembly

18. With the new pump installed, unlock and pull out the pump drawer.
19. With the pump drawer opened, reconnect the vacuum, exhaust, and ac connector.
20. Close the pump drawer.
21. Close and secure the pump cooling fan door.

Replace Exhaust by-Pass Filters

1. Remove old filters by depressing the quick connect fitting
2. Pull out old filters and install new filters, ensure the arrow on the new filter is point in towards the valve as shown.

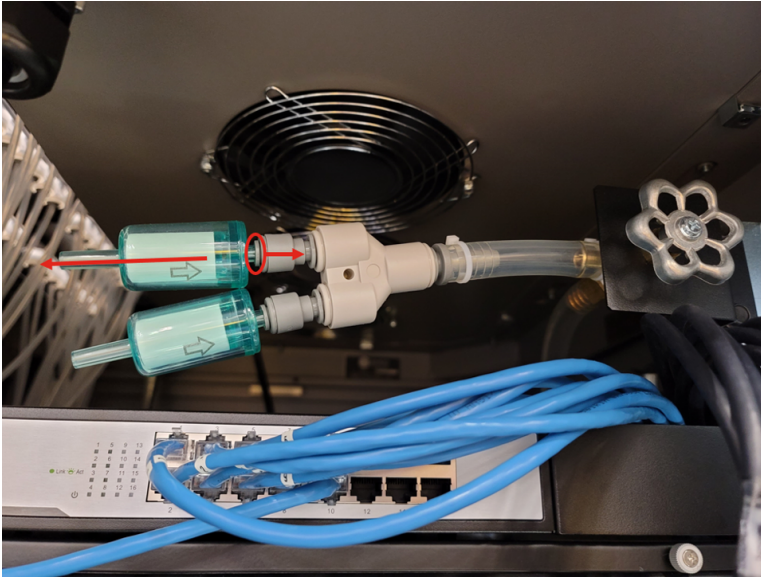

Orifice Filter Inspection, Cleaning & Replacement

- The orifice is protected by a mesh filter.
In the event that a particle or foreign object makes it past the end of sample line filter this mesh filter will protect the orifice from clogging and slowing down sample transport times.
- This should be inspected every 6 months for debris or contamination and can be cleaned with compressed air.
- In the event that the filter can not be cleaned it should be replaced.
 - Replacement Part: 1502A0155

NOTE

This inspection should only take place on analyzers that are disconnected from the rack, or if the ENTIRE rack is out of monitor mode.

1. Release the Analyzer from the rack (refer to See "Release the Analyzer Lock" on page 99 for more information.)
2. Remove the orifice Panel on the side of the Analyzer by unscrewing the thumbscrew



3. Thread in the orifice removal tool 1502-0166 or a 6-32 screw into the orifice cartridge and pull back to remove it from the manifold

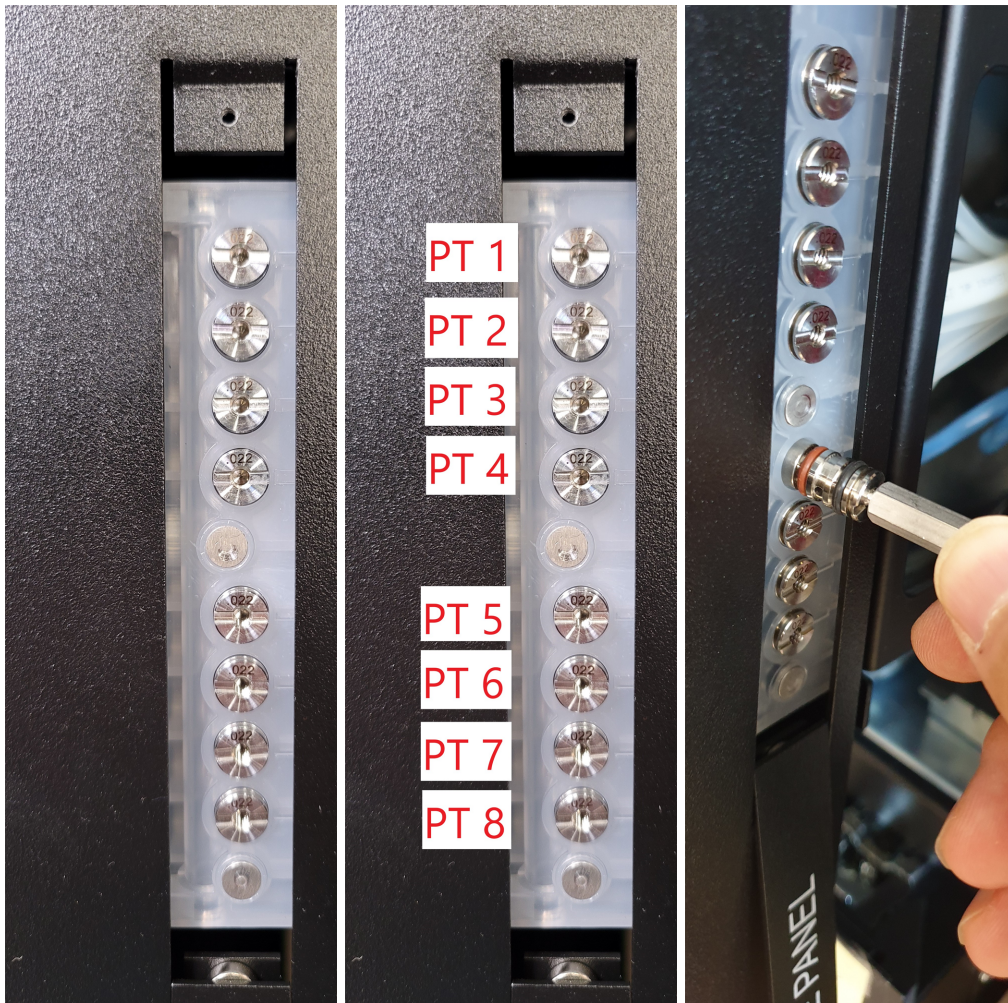

4. Once removed inspect the cartridge for any debris on the surface of the filter.



5. If there is any debris clean it with compressed air.
6. Once cleaned replace the orifice into the cavity it came from.
 - Check that the orifice is fully installed into the manifold

7. Align the slot on the back side of the orifice to be horizontal as shown.

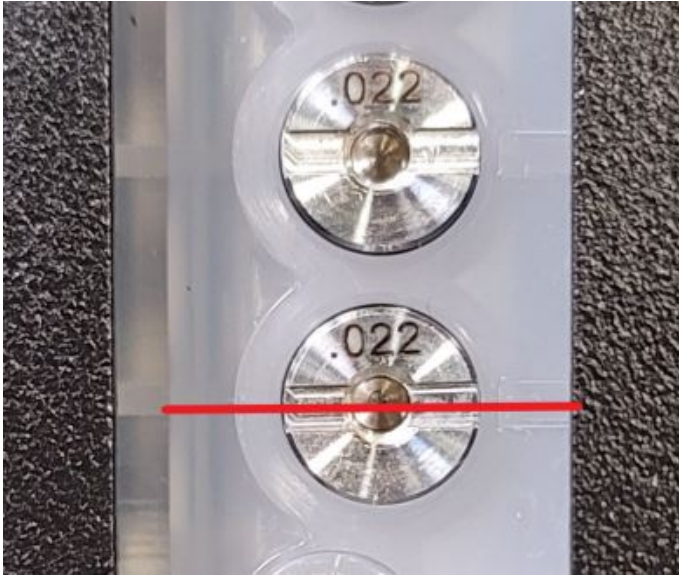

8. Repeat the process with the rest of the points
9. Once all points are cleaned replace the orifice panel

Clean the Touchscreen

Clean the touch screen display with a lightly moistened towel. Do not spray cleaner directly onto the glass. Excess liquid will run down the screen and interfere with operation.

For further reference, refer to the Touchscreen User Manual for any additional information.

Clean the Optics

Clean Chemcassette optics annually or whenever optics verification error occurs.

Compressed air is required or per the locations PM schedule.

1. Make sure the Analyzer is out of Monitor Mode.
2. Open the Optics Block Gate.
3. Remove the Chemcassette by releasing and pulling out the analyzer.
4. Open the Vertex Edge side panel.
5. Remove tubing (shown in photo) one at a time and blow out with compressed air.



6. Re-secure side panel and reload the Chemcassette.

NOTE

Remove and clean one port at a time to insure proper orientation of tubing. Do not remove the capillary tubing (microtubes). After cleaning the Optics, the cleaning counter should be reset to avoid unnecessary maintenance warning due to Optics cleaning due. (See "Clean the Optics" above for more information.)



CAUTION

Failure to replace and retighten hardware after service can adversely affect instrument performance and electromagnetic radiation compliance (EMC). Make certain all fasteners are reinstalled and firmly fastened.

6

Additional Information

Learn about strategic information related to the Honeywell Vertex™ Edge Detector.

Specifications

OVERALL SYSTEM DIMENSION	
Size	76" x 24" x 35"
Weight - Full loaded condition	Full ~900lbs (~408kg)
Weight - Empty rack	Empty ~655lbs (~297kg)
ANALYZER	
Size	22" x 13" x 6"
Weight	≤ 27lbs (12kg)
POWER REQUIREMENTS	
Operating voltage	230VAC+/-10% (under load) @ 50/60Hz: 15A, single phase
POWER CONSUMPTION	
Normal condition	1.1k Watt
Maximum condition	≤ 1.4k Watt
DISPLAY AND OUTPUTS	
Visual	15.6" wide screen monitor with capacitive touch interface Display gas reading, alarm & instrument status real-time base Provide real-time trend chart and gas event snapshot trend chart Event logging including maintenance/instrument fault and gas alarm Multiple searching option for the event LED indicator: Normal (Green), Alarm 1 (Red), Alarm 2 (Red), Fault (Yellow)
Digital	TCP/IP and RTU Modbus, OPC (Option)

communications	
SECURITY	
	Role-based access control Support HTTPS
CERTIFICATION AND SPECIFICATION	
	EN 50270 and EN61010-1 UL/IEC 61010-1 RED, FCC for RFID
PERFORMANCE	
	Refer to product manual for complete gas list
Flow rate	2.1 LPM
Transport time	Less than 50 seconds up to 325ft with thin wall tube (0.190"ID). For more information refer to See "Transport Time " on page 173 for more information.
Sample line tubing	1/4 in. (6.35 mm) O.D. x 0.190in. (4.83 mm) (Thin wall)
Tubing length	Up to 400ft (120m) with thin wall
Exhaust line tubing	1/2 in. (12.7 mm) O.D. x 3/8 in. (9.5 mm) I.D. Teflon tubing
Exhaust length	Up to 50 ft. (15 m) maximum
OPERATING CONDITIONS	
Temperature	59°F to 95°F (15°C to 35°C)
Humidity	20-65% RH
Altitude	-1000 ft. (-305 m) to 6000 ft. (1829 m) above sea level
Pollution degree	2
WIRING REQUIREMENT	
Power	Singe phase power, Minimum 14 AWG
Digital	Modbus TCP/IP: CAT5 shielded cable or equivalent (RJ45 connector); Modbus RTU: 2-wire stranded, shielded cable or equivalent (24-14 AWG)
Transportation Flow	Flow varies depending on tube length. For more information refer to See "Nominal Transport Times" on page 178 for more information.
Transportation Time	For more information refer to See "Transport Time " on page 173 for more information.

Detectable Gases

Vertex Edge System Chemcassette analyzers are continuous monitoring instruments. The initial analysis period listed in the following table varies based on the programmed alarm levels. This period is valid only after the system pulls a new Chemcassette window. Increasing the programmed alarm levels will decrease the initial sample period.

For accurate detection, gas must be present at sufficient levels and durations. Typical response times are shown in this table at 2 TLV, which will vary in duration depending on the target gas and alarm level settings. For high concentrations (greater than full scale) a minimum of 4 seconds is required.

Family	CC Name (P/N)	Table	Gas Name	TLV	LAL	LDL	Default Alarm Level 1	Default Alarm Level 2	Range	Alarm Setting	Initial Analysis Period (second)	Time to 1TLV alarm @ 2TLV concentration, 10ft sample line
1	XPV Hydrides (1295-0226)	1	Arsine XP (AsH3)	5 ppb	3 ppb	2.5 ppb	50 ppb	100 ppb	0-500 ppb	3-500 ppb	30	<24 sec (Alarm @ 50 ppb with 100 ppb AsH3 gas)
		2	Arsine XP (AsH3) Low Level	5 ppb	0.5 ppb	0.3 ppb	2.5 ppb	5 ppb	0-50 ppb	0.5-1.9 ppb 2-4.9 ppb 5-9.9 ppb 10-50 ppb	300 150 60 30	<60 sec
		3	Diborane XP (B2H6)	100 ppb	15 ppb	10 ppb	100 ppb	200 ppb	0-1000 ppb	15-49 ppb 50-99 ppb 100-1000 ppb	60 45 30	<45 sec
		4	Germane XP (GeH4)	200 ppb	100 ppb	100 ppb	200 ppb	400 ppb	0-2000 ppb	100-149 ppb 150-199 ppb 200-2000 ppb	480 360 240	<200 sec
		5	Phosphine XP (PH3)	50 ppb	5 ppb	5 ppb	300 ppb	600 ppb	0-3000 ppb	5-3000 ppb	15	<30 sec (Alarm @ 50ppb with 100ppbPH3 gas)
		6	Silane XP (SiH4)	5 ppm	0.5 ppm	0.3 ppm	5 ppm	10 ppm	0-50 ppm	0.5-4.9 ppm 5-9.9 ppm 10-19.9 ppm 20-50 ppm	60 45 30 15	<35 sec
		7	Silane-M XP (SiH4-M)	5 ppm	0.06ppm	0.05 ppm	2.5 ppm	5.0 ppm	0.05-15 ppm	0.05-2.49 ppm 2.5-4.99 ppm 5-9.99 ppm 10-15 ppm	180 60 45 30	<35 sec
		8	Hydrogen Sulfide XP (H2S)	1 ppm	0.2 ppm	0.1 ppm	1 ppm	2 ppm	0-10 ppm	0.2-0.4 ppm 0.5 - 0.9 ppm 1-1.9 ppm 2-10 ppm	45 30 15 10	<20 sec
		9	Hydrogen Sulfide XP (H2S) Low Level	1 ppm	20 ppb	15 ppb	500 ppb	1000 ppb	0-2000 ppb	20-99 ppb 100-199 ppb 200-399 ppb 400-2000 ppb	120 60 30 15	<20sec (Alarm @ 500 ppb with 1000 ppb H2S gas)

Family	CC Name (P/N)	Table	Gas Name	TLV	LAL	LDL	Default Alarm Level 1	Default Alarm Level 2	Range	Alarm Setting	Initial Analysis Period (second)	Time to 1TLV alarm @ 2TLV concentration, 10ft sample line
		10	Hydrogen Selenide XP (H ₂ Se)	50 ppb	8 ppb	6 ppb	50 ppb	100 ppb	0-500 ppb	8-49 ppb 50-99 ppb 100-500 ppb	180 120 60	<45 sec
2	XPV4 Hydrides (1257-9300)	1	Arsine XP4 (AsH ₃)	5 ppb	3 ppb	2.5 ppb	50 ppb	100 ppb	0-500 ppb	3-500 ppb	30	<24 sec (Alarm @ 50 ppb with 100 ppb AsH ₃ gas)
		2	Arsine XP4 (AsH ₃) Low Level	5 ppb	0.5 ppb	0.3 ppb	2.5 ppb	5 ppb	0-50 ppb	0.5-1.9 ppb 2-4.9 ppb 5-9.9 ppb 10-50 ppb	300 150 60 30	<60 sec
		3	Diborane XP4 (B ₂ H ₆)	100 ppb	15 ppb	10 ppb	100 ppb	200 ppb	0-1000 ppb	15-49 ppb 50-99 ppb 100-1000 ppb	60 45 30	<45 sec
		4	Germane XP4 (GeH ₄)	200 ppb	100 ppb	100 ppb	200 ppb	400 ppb	0-2000 ppb	100-149 ppb 150-199 ppb 200-2000 ppb	480 360 240	<200 sec
		5	Phosphine XP4 (PH ₃)	50 ppb	5 ppb	5 ppb	300 ppb	600 ppb	0-3000 ppb	5-3000 ppb	15	<30 sec (Alarm @ 50ppb with 100ppbPH ₃ gas)
		6	Silane XP4 (SiH ₄)	5 ppm	0.5 ppm	0.3 ppm	5 ppm	10 ppm	0-50 ppm	0.5-4.9 ppm 5-9.9 ppm 10-19.9 ppm 20-50 ppm	60 45 30 15	<35 sec
		7	Silane-M XP4 (SiH ₄ -M)	5 ppm	0.06 ppm	0.05 ppm	2.5 ppm	5.0 ppm	0.05-15 ppm	0.05-2.49 ppm 2.5-4.99 ppm 5-9.99 ppm 10-15 ppm	180 60 45 30	<35 sec
		8	Hydrogen Sulfide XP4 (H ₂ S)	1 ppm	0.2 ppm	0.1 ppm	1 ppm	2 ppm	0-10 ppm	0.2-0.4 ppm 0.5 - 0.9 ppm 1-1.9 ppm 2-10 ppm	45 30 15 10	<20 sec
		9	Hydrogen Sulfide XP4 (H ₂ S) Low Level	1 ppm	20 ppb	15 ppb	500 ppb	1000 ppb	0-2000 ppb	20-99 ppb 100-199 ppb 200-399 ppb 400-2000 ppb	120 60 30 15	<20sec (Alarm @ 500 ppb with 1000 ppb H ₂ S gas)
		10	Hydrogen Selenide XP4 (H ₂ Se)	50 ppb	8 ppb	6 ppb	50 ppb	100 ppb	0-500 ppb	8-49 ppb 50-99 ppb 100-500 ppb	180 120 60	<45 sec
3	XP6 Hydrides (1507-9300)	1	Arsine XP6 (AsH ₃)	5 ppb	3 ppb	2.5 ppb	50 ppb	100 ppb	0-500 ppb	3-500 ppb	30	<24 sec (Alarm @ 50 ppb with 100 ppb AsH ₃ gas)
		2	Arsine XP6 (AsH ₃) Low	5 ppb	0.5 ppb	0.3 ppb	2.5 ppb	5 ppb	0-50 ppb	0.5-1.9 ppb	300	<60 sec

Family	CC Name (P/N)	Table	Gas Name	TLV	LAL	LDL	Default Alarm Level 1	Default Alarm Level 2	Range	Alarm Setting	Initial Analysis Period (second)	Time to 1TLV alarm @ 2TLV concentration, 10ft sample line
			Level							2-4.9 ppb 5-9.9 ppb 10-50 ppb	150 60 30	
		3	Diborane XP6 (B2H6)	100 ppb	15 ppb	10 ppb	100 ppb	200 ppb	0-1000 ppb	15-49 ppb 50-99 ppb 100-1000 ppb	60 45 30	<45 sec
		4	Germane XP6 (GeH4)	200 ppb	100 ppb	100 ppb	200 ppb	400 ppb	0-2000 ppb	100-149 ppb 150-199 ppb 200-2000 ppb	480 360 240	<200 sec
		5	Phosphine XP6 (PH3)	50 ppb	5 ppb	5 ppb	300 ppb	600 ppb	0-3000 ppb	5-3000 ppb	15	<30 sec (Alarm @ 50ppb with 100ppbPH3 gas)
		6	Silane XP6 (SiH4)	5 ppm	0.5 ppm	0.3 ppm	5 ppm	10 ppm	0-50 ppm	0.5-4.9 ppm 5-9.9 ppm 10-19.9 ppm 20-50 ppm	60 45 30 15	<35 sec
		7	Silane-M XP6 (SiH4-M)	5 ppm	0.06 ppm	0.05 ppm	2.5 ppm	5.0 ppm	0.05-15 ppm	0.05-2.49 ppm 2.5-4.99 ppm 5-9.99 ppm 10-15 ppm	180 60 45 30	<35 sec
		8	Hydrogen Sulfide XP6 (H2S)	1 ppm	0.2 ppm	0.1 ppm	1 ppm	2 ppm	0-10 ppm	0.2-0.4 ppm 0.5 - 0.9 ppm 1-1.9 ppm 2-10 ppm	45 30 15 10	<20 sec
		9	Hydrogen Sulfide XP6 (H2S) Low Level	1 ppm	20 ppb	15 ppb	500 ppb	1000 ppb	0-2000 ppb	20-99 ppb 100-199 ppb 200-399 ppb 400-2000 ppb	120 60 30 15	<20sec (Alarm @ 500 ppb with 1000 ppb H2S gas)
		10	Hydrogen Selenide XP6 (H2Se)	50 ppb	8 ppb	6 ppb	50 ppb	100 ppb	0-500 ppb	8-49 ppb 50-99 ppb 100-500 ppb	180 120 60	<45 sec
4	XP Mineral Acids (1295-0507)	1	Boron Trifluoride XP (BF3)	0.1 ppm	0.05 ppm	0.04 ppm	0.1 ppm	0.2 ppm	0-10 ppm	0.05-0.99 ppm 1.0-10.0 ppm	45 30	<100 sec (Alarm @0.1ppm with 0.2ppm BF3 gas)
		2	Hydrogen Bromide XP (HBr)	2 ppm	0.3 ppm	0.2 ppm	2 ppm	4 ppm	0-20 ppm	0.3-1.9 ppm 2-20 ppm	45 30	<50 sec
		3	Hydrogen Bromide XP (HBr) Low Level	2 ppm	30 ppb	20 ppb	200 ppb	400 ppb	0-2000 ppb	30-99 ppb 100-399 ppb 400-2000 ppb	180 120 60	<200 sec (Alarm @ 0.2 ppb with 0.4 ppb HBr gas)

Family	CC Name (P/N)	Table	Gas Name	TLV	LAL	LDL	Default Alarm Level 1	Default Alarm Level 2	Range	Alarm Setting	Initial Analysis Period (second)	Time to 1TLV alarm @ 2TLV concentration, 10ft sample line
		4	Hydrogen Chloride XP (HCl)	2 ppm	0.2 ppm	0.2 ppm	2 ppm	4 ppm	0-20 ppm	0.2-0.9 ppm 1-3.9 ppm 4-20 ppm	60 30 20	<40 sec
		5	Hydrogen Chloride XP (HCl) Low Level	2 ppm	30 ppb	20 ppb	200 ppb	400 ppb	0-2000 ppb	30-199 ppb 200-399 ppb 400-2000 ppb	240 150 90	<135 sec (Alarm @ 200 ppb with 400 ppb HCl gas)
		6	Hydrogen Fluoride XP (HF)	0.5 ppm	0.4 ppm	0.4 ppm	2 ppm	4 ppm	0-20 ppm	0.4-0.9 ppm 1-3.9 ppm 4-20 ppm	240 90 60	<50 (Alarm @ 2ppm with 4ppmHF gas)
		7	Hydrogen Fluoride XP (HF) Low Level	500 ppb	30 ppb	20 ppb	500 ppb	1000 ppb	0-2000 ppb	30-99 ppb 100-199 ppb 200-399 ppb 400-2000 ppb	360 240 120 90	<85 sec (Alarm @500ppb with 1000ppmHF gas)
		*Due to U.S. Government regulations, this range may be subject to restrictions requiring special licensing for certain countries outside North America. Contact Honeywell for eligibility information.										
5	XP 4 Mineral Acids (1257-9310)	1	Boron Trifluoride XP4 (BF3)	0.1 ppm	0.05 ppm	0.04 ppm	0.1 ppm	0.2 ppm	0-10 ppm	0.05-0.99 ppm 1.0-10.0 ppm	45 30	<100 sec (Alarm @0.1ppm with 0.2ppm BF3 gas)
		2	Hydrogen Bromide XP4 (HBr)	2 ppm	0.3 ppm	0.2 ppm	2 ppm	4 ppm	0-20 ppm	0.3-1.9 ppm 2-20 ppm	45 30	<50 sec
		3	Hydrogen Bromide XP4 (HBr) Low Level	2 ppm	30 ppb	20 ppb	200 ppb	400 ppb	0-2000 ppb	30-99 ppb 100-399 ppb 400-2000 ppb	180 120 60	<200 sec (Alarm @ 0.2 ppb with 0.4 ppb HBr gas)
		4	Hydrogen Chloride XP4 (HCl)	2 ppm	0.2 ppm	0.2 ppm	2 ppm	4 ppm	0-20 ppm	0.2-0.9 ppm 1-3.9 ppm 4-20 ppm	60 30 20	<40 sec
		5	Hydrogen Chloride XP4 (HCl) Low Level	2 ppm	30 ppb	20 ppb	200 ppb	400 ppb	0-2000 ppb	30-199 ppb 200-399 ppb 400-2000 ppb	240 150 90	<135 sec (Alarm @ 200 ppb with 400 ppb HCl gas)
		6	Hydrogen Fluoride XP4 (HF)	0.5 ppm	0.4 ppm	0.4 ppm	2 ppm	4 ppm	0-20 ppm	0.4-0.9 ppm 1-3.9 ppm 4-20 ppm	240 90 60	<50 (Alarm @ 2ppm with 4ppmHF gas)
		7	Hydrogen Fluoride XP4 (HF) Low Level	500 ppb	30 ppb	20 ppb	500 ppb	1000 ppb	0-2000 ppb	30-99 ppb 100-199 ppb 200-399 ppb 400-2000 ppb	360 240 120 90	<85 sec (Alarm @500ppb with 1000ppmHF gas)
		*Due to U.S. Government regulations, this range may be subject to restrictions requiring special licensing for certain countries outside North America. Contact Honeywell for eligibility information.										
6	XP Ammonia (1295-0405)	1	Ammonia XP (NH3)	25 ppm	1.5 ppm	1.5 ppm	25 ppm	50 ppm	0-150 ppm	1.5 - 49.9 ppm 50 - 150 ppm	10 5	<25 sec

Family	CC Name (P/N)	Table	Gas Name	TLV	LAL	LDL	Default Alarm Level 1	Default Alarm Level 2	Range	Alarm Setting	Initial Analysis Period (second)	Time to 1TLV alarm @ 2TLV concentration, 10ft sample line
		2	Dimethylamine XP (DMA)	5.0 ppm	0.5 ppm	0.5 ppm	5 ppm	10 ppm	0-50.0 ppm	0.5-2.4 ppm 2.5-50.0 ppm	15 10	<30 sec
		3	Tetrakis Dimethylamino Titanium XP (TDMAT)	None Established	0.1 ppm	0.1 ppm	1.0 ppm	2.0 ppm	0-10 ppm	0.1-0.4 ppm 0.5-10.0 ppm	15 10	<30 sec (Alarm @1ppb with 2ppm TDMAT gas)
7	XP4 Ammonia (1257-9309)	1	Ammonia XP4 (NH3)	25 ppm	1.5 ppm	1.5 ppm	25 ppm	50 ppm	0-150 ppm	1.5 - 49.9 ppm 50 - 150 ppm	10 5	<25 sec
		2	Dimethylamine XP4 (DMA)	5.0 ppm	0.5 ppm	0.5 ppm	5.0 ppm	10.0 ppm	0-50.0 ppm	0.5-2.4 ppm 2.5-50.0 ppm	15 10	<30 sec
		3	Tetrakis Dimethylamino Titanium XP4 (TDMAT)	None Established	0.1 ppm	0.1 ppm	1.0 ppm	2.0 ppm	0-10 ppm	0.1-0.4 ppm 0.5-10.0 ppm	15 10	<30 sec (Alarm @1ppb with 2ppmTDMAT gas)
8	XP6 Ammonia (1507-9309)	1	Ammonia XP6 (NH3)	25 ppm	1.5 ppm	1.5 ppm	25 ppm	50 ppm	0-150 ppm	1.5 - 49.9 ppm 50 - 150 ppm	10 5	<25 sec
		2	Dimethylamine XP6 (DMA)	5.0 ppm	0.5 ppm	0.5 ppm	5.0 ppm	10.0 ppm	0-50.0 ppm	0.5-2.4 ppm 2.5-50.0 ppm	15 10	<30 sec
		3	Tetrakis Dimethylamino Titanium XP6 (TDMAT)	None Established	0.1 ppm	0.1 ppm	1.0 ppm	2.0 ppm	0-10 ppm	0.1-0.4 ppm 0.5-10.0 ppm	15 10	<30 sec (Alarm @1ppb with 2ppmHF gas)
9	Phosgene (1295-0228)	1	Phosgene XP (COCl2)	100 ppb	10 ppb	7 ppb	100 ppb	200 ppb	0-1000 ppb	10-49 ppb 50-99 ppb 100-199 ppb 200-4000 ppb	60 45 30 15	<30 sec
		2	Phosgene XP (COCl2) High Range	100 ppb	10 ppb	7 ppb	100 ppb	200 ppb	0-4000 ppb	10-49 ppb 50-99 ppb 100-199 ppb 200-4000 ppb	60 45 30 15	<30 sec
10	Phosgene (1257-9309)	1	Phosgene XP4 (COCl2)	100 ppb	10 ppb	7 ppb	100 ppb	200 ppb	0-1000 ppb	10-49 ppb 50-99 ppb 100-199 ppb 200-4000 ppb	60 45 30 15	<30 sec
		2	Phosgene XP4 (COCl2) High Range	100 ppb	10 ppb	7 ppb	100 ppb	200 ppb	0-4000 ppb	10-49 ppb 50-99 ppb 100-199 ppb 200-4000 ppb	60 45 30 15	<30 sec
11	XPV Chlorine-II (1295-0560)	1	Fluorine XP-Cl2-II (F2)	0.1 ppm	0.06 ppm	0.06 ppm	1 ppm	2 ppm	0-10 ppm	0.06-1.99 ppm 2.0-3.90 ppm 4.0-10.0 ppm	90 60 30	<75 sec (Alarm @ 0.1ppm with 0.2ppm F2 gas)
		2	Fluorine XP-Cl2-II (F2)	0.1 ppm	0.05 ppm	0.03	0.1 ppm	0.2 ppm	0-1.0 ppm	0.05-0.199 ppm	120	<85 sec (Alarm @ 0.1ppm

Family	CC Name (P/N)	Table	Gas Name	TLV	LAL	LDL	Default Alarm Level 1	Default Alarm Level 2	Range	Alarm Setting	Initial Analysis Period (second)	Time to 1TLV alarm @ 2TLV concentration, 10ft sample line
			(Low Level)			ppm				0.2-1.0 ppm	60	with 0.2ppmF2 gas)
		3	Chlorine XP-Cl2-II (Cl2)	0.1 ppm	0.06 ppm	0.05 ppm	0.5 ppm	1 ppm	0-5 ppm	0.06-0.24 ppm 0.25-5.0 ppm	45 30	<40sec (Alarm @ 0.1ppm with 0.2ppmCl2 gas). <20sec (Alarm @ 0.5ppm with 1.0ppmCl2 gas)
		4	Chlorine XP-Cl2-II (Cl2) (Low Level)	0.1 ppm	0.03 ppm	0.007 ppm	0.1 ppm	0.2 ppm	0-1.0 ppm	0.03 - 0.099 ppm 0.1 - 0.199 ppm 0.2 -1.0 ppm	120 90 60	<110 sec (Alarm @ 0.1ppm with 0.2ppmCl2 gas)
12	Fluorine/Oxidizer (1295-0220)	1	Chlorine (Cl2)	0.1 ppm	0.05 ppm	0.04 ppm	0.5 ppm	1 ppm	0-5 ppm	0.05-0.24 ppm 0.25-0.49 ppm 0.5-5 ppm	45 30 15	<40 sec (Alarm @ 0.5ppm with 1ppm Cl2 gas)
		2	Fluorine (F2)	0.1 ppm	0.1 ppm	0.06 ppm	1 ppm	2 ppm	0-10 ppm	0.1-0.9 ppm 1.0-10 ppm	60 30	<80 sec (Alarm @ 0.1ppm with 0.2 ppmF2 gas)
		3	Nitrogen Dioxide (NO2)	0.2 ppm	0.1 ppm	0.1 ppm	0.2 ppm	0.4 ppm	0-30 ppm	0.1-8.9 ppm 9-30 ppm	240 120	<350 sec
13	Sulfur Dioxide (1295-0552)	1	Sulfur Dioxide (SO2)	250 ppb	30 ppb	25 ppb	250 ppb	500 ppb	0-2500 ppb	30-249 ppb 250-2500 ppb	60 30	<60 sec
14	Hydrogen Cyanide (1295-0222)	1	Hydrogen Cyanide (HCN)	4.7 ppm	1 ppm	0.5 ppm	4.7 ppm	9.4 ppm	0-30 ppm	1-9.9 ppm 10-19.9 ppm 20-30 ppm	30 20 15	<15 sec
15	XP4 Chlorine (1257-9308)	1	Chlorine (Cl2)	0.1ppm	0.05 ppm	0.05 ppm	0.5 ppm	1.0 ppm	0-5 ppm	0.05-0.24 ppm 0.25-5.0 ppm	45 30	<53 sec
		2	Chlorine (Cl2) (Low Level)	100 ppb	30 ppb	7 ppb	100 ppb	200 ppb	0 - 2000 ppb	30 - 199 ppb 200 - 499 ppb 500 -2000 ppb	120 90 60	<65 sec

TLV - Threshold Limit Value – LAL - Lowest Alarm Level – LDL - Low Detection Limit

The response time (T50) generally indicates the amounts of time required to display 50% of the accurate reading of the actual gas concentration, determined under standard Lab condition (20-25 C, 42-46%RH) at the standard analysis point flow rate 200cc/min. The performance efficiency including response accuracy and response time can deviate depending on sample gas conditions. (ex. The response time will be extended at higher RH condition due to absorption onto the sample line.)

Maintenance Faults

A maintenance fault indicates the Vertex Edge System requires attention but is continuing to monitor.

Event ID	Description	Possible Cause	Resolution
101	Flow is 70 cc/min less than nominal	Excessive point vacuum due to clog or kinked sample line	Check sample line and line filter. Clean the sample line and replace filter. Correct sample line issue.
		Sample line too long or ID too small	Ensure sample line requirements are with specifications
		Poor gate seal	Check nut on the optic block
			Contact Honeywell Analytics Service
		Supply vacuum insufficient (less than 7inHg)	Plug pneumatic connector in unused slots Exhaust tubing restricted Service or switch pumps
		Condensation	Check internal lines for moisture
		Chemcassette thickness variation	Advance the Chemcassette.
Adjust the needle valve to achieve 200cc/min.			
Contact Honeywell Analytics Service.			
102	Remaining Chemcassette is low	Less than preset reminder on the Chemcassette	Replace the Chemcassette
103	Analyzer out of monitor too long	Analyzer out of monitor	Reset all alarms and faults, and then return analyzer to Monitor Mode
		Out of Monitor time limit too short	Change time limit in Configuration Profile
104	Run time point disable timeout	Alarms were manually bypassed	Restore point to alarm active mode
		Run Time Point Disable time limit too short	Change time limit in Configuration Profile
105	Sample pressures greater than ambient	Point pressure above atmospheric pressure while in idle	Review sample line location. Confirm atmospheric conditions.
		Pressure sensor Calibration error, Defective sensor	Contact Honeywell Analytics Service
106	Flow is 70 cc/min more than nominal	Chemcassette thickness variation	Advance the Chemcassette.
			Adjust the needle valve to achieve 200cc/min.
			Contact Honeywell Analytics Service.
		Defective needle valve	Replace needle valve
107	Chemcassette expired	Chemcassette expiration date reached	Replace Chemcassette
		Chemcassette installed past its expiration date	Replace Chemcassette
108	No polls from HMI	Communications to HMI PC interrupted longer than 10 seconds	Check Ethernet cable at rear of analyzer. Check Ethernet hub connection and operation. Check Ethernet connection to HMI PC.

Event ID	Description	Possible Cause	Resolution
			Contact Honeywell Analytics Service.
109	Single pump failure	Pump failure	Rebuild/Replace non-operating pump
		Unused slots not plugged	Install connector plug on unused slot
		Check valve on inactive pump leaking	Replace check valve Contact Honeywell Analytics Service
110	Optics Block Dirty - Cleaning Required	Optic block dirty	Clean optics. Contact Honeywell Analytics Service.
		Optic block is aged	Replace optics block
		Tape leader installed improperly	Reload Chemcassette and recalibrate using leader
111	Sample Pressure High	End of line filter clogged	Replace end of line filter
		Sample line kinked	Isolate by disconnecting possible crimped sample line
		Too small ID and/or Maximum line length exceeded	Check sample tube ID and length
		Crimped tube in cable carrier	Identify crimps in tubing harness by checking pressure with analyzer closed vs. open
112	Analyzer restart failed after pump swap	Control related fault is issued because of an improper control response from another analyzer	Verify the pump connects are connected. Verify all analyzers enter monitor mode successfully.
113	Pump Over Temperature	Fan failure	Check fans in pump module
		Line voltage less than 208 VAC or higher than 240VAC	Verify main line voltage
			Check the connections to the Thermal Switch. Sensor located behind the pumps.
114	High Exhaust Pressure	Kinked exhaust	Check exhaust tubing for kinks or restrictions
		Exhaust tubing length exceeds 50ft. (15m.)	Reroute to reduce length
		Exhaust line restricted	Clean Exhaust line. Replace Exhaust line.
115	Power Supply failure	Power line disconnected	Check power line from PDU to Analyzer
116	Optics Temperature Out Of Range	Hot or Cold environment	Relocate Vertex Edge
		Electronic problem	Replace optics block
		Cooling air failure	Replace fans
117	PDU Temperature Out Of Range	Hot or Cold environment	Relocate Vertex Edge
		Electronic problem	Replace PDU
118	Filter Timer Expired	Maintenance reminder, no malfunction	Change filter and reset timer
119	Optics Cleaning Timer Expired	Maintenance reminder, no malfunction	Clean the Optics and reset timer
120	Pump Maintenance Timer Expired	Maintenance reminder, no malfunction	Rebuild pump and reset timer
121	LIT has no reference data	Point was disabled in configuration when previous LIT characterization was performed	Perform characterization or disable LIT test for point in

Event ID	Description	Possible Cause	Resolution
			configuration
122	Inadequate signal for characterization	Check valve not installed	Install check valve or disable LIT test in config
		Sample tubing cut or leaking	Replace tubing
123	Sample line leak detected	Sample tubing cut or leaking	Replace tubing
		Ambient pressure at sampled point differs from Vertex exhaust by more than 0.5inHg (1.69KPa)	Revise installation Disable LIT for affected point
		Check valve not seating	Replace check valve
124	LIT Coordination Failure	Some analyzers were in LOADCC or other special mode	None needed
		Software anomaly	If repeated, notify Honeywell Analytics Service
125	Possible debris in optics block	Debris in optics block	Clean optics block
126	Abnormal Optics reading detected	Compensated optic reading automatically. So no further action required. But too frequently happens, debris in the optic block.	Clean optics block
127	Accelerated Chemcassette Usage	Low level background gas below lower detectable limit	Locate source of background gas
128	Ethernet initialization failed	Failed load the driver, Electronic problem	Reboot the analyzers. Contact Honeywell Analytics Service.
129	File system of Analyzer is corrupted	File system corrupted	Contact Honeywell Analytics Service
130	Optics blocks have different software versions	Program update done incorrectly	Reload program to both optics blocks.
131	Unable To Log event data	File system corrupted	Contact Honeywell Analytics Service
132	Software version mismatched among Analyzers	New analyzer was installed into the Vertex Edge rack that contains a different software revision than the other analyzers	Upgrade analyzer Software
133	This Chemcassette is nearing its expiration date.	Chemcassette not used too long	Replace Chemcassette
134	Chemcassette Type Not Matched	Chemcassette with wrong gas family installed	Reinstall Configuration Profile
135	Analyzer configuration failed	Analyzer configuration failed	Reinstall Configuration Profile
136	Point configuration failed	Point configuration failed	Check alarm settings and reinstall Configuration Profile

Event ID	Description	Possible Cause	Resolution
137	Could not start monitoring	Instrument faults not cleared.	Resolve the reported instrument faults and reset all faults
		Invalid RFID tag detected	Reinstall Configuration Profile or Replace Chemcassette
		All points disabled	Reinstall Configuration Profile or enable runtime disabled points
		Invalid Analyzer/Point Configuration	Reinstall Configuration Profile
		LIT in progress	Wait until LIT test is complete and restart monitoring mode
		Tape Advance Failure	See recoveries for Fault 233
138	Analyzer RTC not set correctly	Low voltage of the coin battery	Replace the coin battery
		RTC failure on the analyzer board	Replace Analyzer.
139	LIT Test/Characterization was not complete	All points disabled	Reinstall Configuration Profile or enable runtime disabled points
		Failed to read/write LIT data	Contact Honeywell service
		Insufficient system vacuum	Adjust system pressure to -11.5 inHg or Contact Honeywell service
		Pump not controlled	Verify the pump connects are connected Replace PDU or contact Honeywell service
		Queen Analyzer (first in the rack) failed to control other Analyzers	Replace first Analyzer in the rack

Instrument Faults

An instrument fault indicates a loss of monitoring on one or more points.

Event ID	Description	Possible Cause	Resolution
201	Chemcassette tape decolored	Improper Chemcassette storage	Confirm Chemcassette storage meeting temperature meets or exceeds the Chemcassette storage requirements Replace Chemcassette
		Tape is too old	Confirm Expiration date will reach the tape length time line Replace Chemcassette
		End of Chemcassette	Replace Chemcassette
		Chemcassette broken	Rethread Chemcassette
202	End Of Chemcassette	Faulty tape encoder	Service analyzer
		Gate opening insufficient	Service analyzer
203	Failed writing hardware configuration	Non-volatile memory failure in analyzer CPU	Retry and reboot the Analyzer. Service or replace analyzer.
204	Failed reading hardware configuration	Non-volatile memory failure in analyzer CPU	Retry and reboot the Analyzer. Service or replace analyzer.
205	Gate motor times out	Gate position sensor not activated before timeout	Check motor operation using Maintenance, Analyzer Operations, Open Gate, or Close Gate
		Motor does not operate	Check motor connections Analyzer PCB in analyzer
		Bad sensor or cable	Check sensor connection to Analyzer PCB. Contact Honeywell service.
206	Gate motor driving failure	Gate position sensor not activated before timeout	Check motor operation using Maintenance, Analyzer Operations, Open Gate, or Close Gate
		Motor does not operate	Check motor connections to Analyzer PCB in analyzer
		Bad sensor or cable	Check sensor connection to Analyzer PCB. Contact Honeywell service
207	Optics signals are noisy	Poor grounding	Replace Analyzer, Contact Honeywell service
		Optics block cover loose	Retighten or reinstall as required
208	Optics counts very low <200	Optics LED not properly calibrated	Perform Replace CC or Adjust Optics operation to recalibrate
		Cable disconnected	Check cable between Optic Block and Analyzer PCB. Contact Honeywell service.
		Optics board defective	Replace the optics block. Contact Honeywell service
		Analyzer CPU defective	Replace Analyzer, Contact Honeywell service

Event ID	Description	Possible Cause	Resolution
209	Gas table file is bad or missing	No configuration loaded	Reinstall Configuration Profile
210	Optics drive unusually low	Optics LED not properly calibrated	Perform Replace CC or Adjust Optics operation to recalibrate
		Optics board defective	Replace the Optics Block. Contact Honeywell service
		Analyzer CPU defective	Replace Analyzer, Contact Honeywell service
211	Optics drive unusually high	Optics LED not properly calibrated	Perform Replace CC or Adjust Optics operation to recalibrate
		LED degraded	Replace the optics block
		Optics board defective	Replace the Optics Block. Contact Honeywell service
		Analyzer CPU defective	Replace Analyzer, Contact Honeywell service
212	Excess optics signal	Optics LED not properly calibrated	Perform Replace CC or Adjust Optics operation to recalibrate
		Optics board defective	Replace the Optics Block. Contact Honeywell service
		Analyzer CPU defective	Replace Analyzer, Contact Honeywell service
213	Double Pump failure	See causes for Fault 109	See recoveries for Fault 109
		Circuit breaker tripped	Contact Honeywell service
214	Flow gone for the specific point	Improper flow setup	Adjust flow to 200cc
		Tape tracking problem	Reload Chemcassette
		Condensation in system	Purge internal lines
		Clogged micro tube	Replace tube. Note: Calibration required, contact Service.
		Gate not fully closing	Gate adjustment loose, pivot binding
		Optics block loose	Tighten optics block fasteners
		Flow adjustment is unstable during adjusting	Replace needle valves
215	Failed to stop Analyzers monitoring mode	Queen Analyzer (first in the rack) failed to communicate with other Analyzers	Replace first Analyzer in the rack
		Analyzer hardware failure	Replace Analyzer, Contact Honeywell service
216	Point Pressure Out Of Range	Miscalibrated sensor board or defective transducer	Replace Analyzer
217	Supply Pressure Out Of Range	Miscalibrated sensor board or defective transducer	Replace Analyzer
218	Inadequate Analyzer Vacuum	Improper system pressure adjustment	Adjust system pressure to 11 inHg
219	Optics SW corrupted	Hardware failure	Replace the Optics Block
220	Optics Internal SW errors	Cable issue	Confirm cable connections
		Hardware failure	Replace the Optics Block. Contact Honeywell service
221	LED adjustment failed due to insufficient optical signal	Optic block dirty	Clean optics. Contact Honeywell Analytics Service.
		Optics LED not properly calibrated	Perform Replace CC or Adjust Optics operation to recalibrate

Event ID	Description	Possible Cause	Resolution
		LED degraded	Replace the optics block
		Optics board defective	Replace the Optics Block. Contact Honeywell service
222	Q-Factor out of range	Chemcassette leader not tight or improperly positioned during white to light gray calibration	Reload Chemcassette
		Bad RFID tag	Load new Chemcassette
		Dirty optics block	Clean and recalibrate
		Bad optics PCB set	Service or replace the optics block.
223	Failed reading dark gray leader	Chemcassette leader not tight or improperly positioned during white to light gray calibration	Reload Chemcassette
		Bad RFID tag	Load new Chemcassette
		Dirty optics block	Clean and recalibrate
		Bad optics PCB	Service or replace the optics block.
224	Failed reading light gray leader	Chemcassette leader not tight or improperly positioned during light gray to dark gray calibration	Reload Chemcassette
		Bad RFID tag	Load new Chemcassette
		Dirty optics block	Clean and recalibrate
		Bad optics PCB	Service or replace analyzer
225	Optics blocks fail at SPI communication	Bad optics PCB	Replace Optics Block
			Service or replace analyzer
226	Optics reference photodiode out of range	Dirty Optics block	Clean optics. Contact Honeywell Analytics Service.
		Hardware failure	Contact Honeywell Analytics Service
227	LED Drive not stable in Optics	Hardware failure	Contact Honeywell Analytics Service
228	Control module not responding to Analyzer	Hardware failure	Contact Honeywell Analytics Service
229	PDU not responding to Analyzer	Hardware failure	Contact Honeywell Analytics Service
230	No valid Chemcassette detected	Chemcassette changed without using Replace CC function	Reload Chemcassette
		Non-Honeywell tape installed	Unauthorized tape installed or expired tape installed.
			Contact Honeywell Analytics Service
231	Chemcassette write failure	RFID board failure	Replace RIFD Board
			Replace Analyzer, Contact Honeywell service

Event ID	Description	Possible Cause	Resolution
232	Internal voltage error	Internal voltage hardware issue	Contact Honeywell Analytics Service
233	Tape advance failure	End of Chemcassette	Replace Chemcassette
		Encode roller not rotating due to loose tape	Reload the Chemcassette tape
		Encoder failure	Replace Encoder
		Cable issue	Check Encoder cabling
			Contact Honeywell Analytics Service
		Stepper Motor Failure	Replace Stepper Motor
Stepper Motor Cable issue	Check Stepper Motor cabling		
	Contact Honeywell Analytics Service		
234	Internal Comm failure	Hardware failure	Contact Honeywell Analytics Service
235	Abnormal Az current consumption is detected	Hardware failure	Contact Honeywell Analytics Service
236	Internal fault at control module	Hardware failure	Contact Honeywell Analytics Service
237	Internal fault at PDU module	Hardware failure	Contact Honeywell Analytics Service
238	Analyzer SW corrupted	Software installation failure	Re-install analyzer software
			Replace Analyzer, Contact Honeywell service
239	Internal SW fault at analyzer	Internal SW operation failed	Reboot the Analyzer. Contact Honeywell service.

Information Events

The Vertex Edge System enters informational and other non-fault events into the event history database. These do not require any action by the user.

Use the event history to check the status of the instrument.

Event ID	Description
2001	Analyzer Powered Up
2002	Detected sub LDL event
2003	First non-zero reading is detected for the window
2004	Windows Zero Reset
2005	Optics Auto Adjust Requested
2006	Optics Auto Adjust Success (LED Drive Adjusted)
2007	Accept new gas family
2008	Optics verification Started
2009	Optics verified Successfully
2010	Q-factors set
2011	Test Optics requested
2012	Started gas monitoring
2013	Stopped gas monitoring
2014	Inhibited point - run time
2015	Released the inhibited point
2016	Disabled a point - run time
2017	Enabled the disabled point - run time
2018	Inhibited point switches back to normal (times out)
2019	New hardware configuration stored
2020	Analyzer accepted new location

Event ID	Description
2021	Reset filter replacement counter
2022	Reset optics cleaning counter
2023	Reset pump maintenance counter
2024	Time changed. Analyzer clock out by >30 seconds
2025	The analyzer rebooted by watchdog
2026	A new chemcassette was installed
2027	Stopped monitoring mode for no enabled points
2028	Override Button - Reset Alarms and Faults
2029	Override Button - Starts Monitoring
2030	Override Button - Stops Monitoring
2032	Pump has been swapped per request
2033	Extra window pull because of flow problems
2034	Analyzer Programmed Successfully
2035	Analyzer Program Failed
2036	Optics Programmed Successfully
2037	Optics Program Failed
2038	Ctrl Module Programmed Successfully
2039	Ctrl Module Program Failed
2040	PDU Module Programmed Successfully
2041	PDU Module Program Failed
2042	Gas table updated
2043	Rejected gas table file
2044	Imported license file successfully

Event ID	Description
2045	Rejected license file
2046	Failed to verify update file
2047	Line integrity test characterized
2048	Line integrity test performed
2050	Reset Single Alarm/Fault.
2051	Reset All Alarms and Faults
2052	Reset All Alarms and Faults - Modbus
2053	Analyzer Configuration updated
2054	Point Configuration updated
2055	Command - Perform LIT Characterization
2056	Command - unscheduled LIT

Transport Time

OD	0.25" Outside Diameter Tubing				
ID	0.190"(Thin Wall) ID				
Length in feet	100	200	300	327	400
Length in meters	30	61	91	100	122
Sample flow	Time in seconds				
1.6 LPM	20.5	40.9	61.4	66.9	81.9
2.1 LPM	15.6	31.2	46.8	51.0	62.4
2.2 LPM	14.9	29.8	44.7	48.7	59.5
2.4 LPM	13.6	27.3	40.9	44.6	54.6

Altitude: Flowrate decreases about 3% per 1000 feet

Altitude [ft]	Normal barometric pressure [inHg]	Multiplier
0	29.92	1.00
500	29.39	0.98
1,000	28.86	0.96
1,500	28.33	0.93
2,000	27.82	0.91
2,500	27.32	0.89
3,000	26.82	0.89
3,500	26.33	0.88
4,000	25.84	0.86
5,000	24.9	0.83
6,000	23.98	0.80

Manual Analyzer Override

The Vertex Edge Analyzer is equipped with a “Manual Override” button in the event the communications to the Vertex Edge Data Acquisition (DAQ) computer halts. This button activates only when the communication has completely ceased.

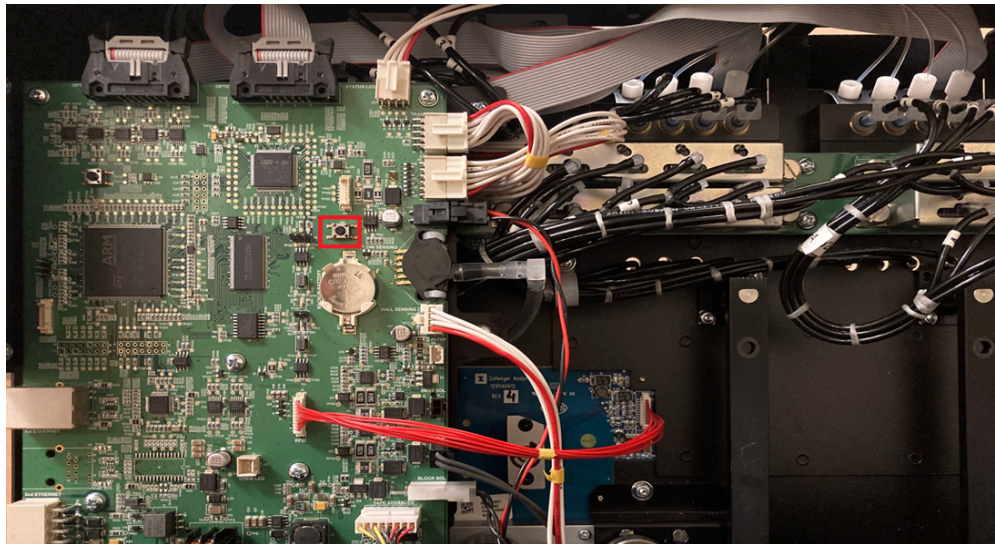

There are cases where the DAq appears to be “frozen” or “locked-up” (no response from the keyboard or any user invoked actions after a few moments) while in reality this is not the case. Events that could cause these symptoms include AC power surges or sags and improper shutdowns of the DAq that result in file corruption. As a result, future attempts to access these files can slow down the response of the DAq. To confirm a non-responsive DAq as opposed to frozen/locked- up, check the clock located in the upper right hand corner of the Vertex Edge HMI window. If the clock is still advancing, then the DAq CPU is not frozen/locked-up and your local Authorized Service Center needs to be contacted for assistance.

On occasion, there may be the need to install a new Chemcassette to continue monitoring your facility, or to reset alarms or faults. If the DAq is not responding, these tasks can be performed using the “Manual Override” button. An extra step may be required to “force” activation of the “Manual Override” button under the above mentioned conditions if the DAq computer is still communicating with the analyzers. The following instructions will instruct you on how to accomplish this task:

NOTE

Performing this task will generate Maintenance Fault F108 – No polls from HMI

1. Manually release the Analyzer by sliding the Removal key (PN: 1295-0341) into slot located in the bottom of the Analyzer front (key installed by the PDU behind the monitor) and slide the Analyzer out of the cabinet.

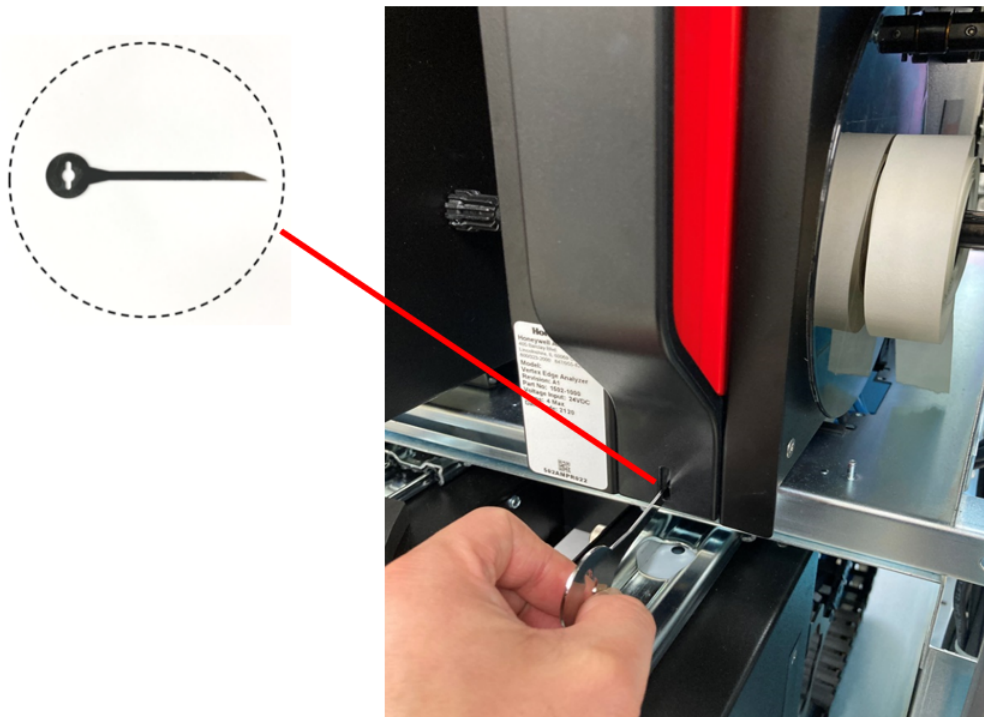

2. Locate the Ethernet cable on the rear panel and disconnect it.
3. Open the side of the Analyzer by unscrewing the 4 thumbscrews at the top of the left side.
4. Approximately 20 seconds after the Ethernet Cable has been disconnected, the Analyzer will recognize that it has lost communications with the DAq and activate the “Manual Override” button. The LED’s on the front of the Analyzer will flash to show a Maintenance Fault per the LED status flash pattern.

To reset faults and alarms press and hold button for 1-3 seconds.

To Exit Monitor and Open Gate press and hold button for 10 seconds and above

To restart monitoring mode, press and hold button for 4 to 9 seconds.

5. Close and reattach the Analyzer cover, reconnect the Ethernet Communications Cable and slide the Analyzer into the cabinet.

Fix an Unresponsive Vertex Edge Touch Screen

Completely resetting the computer can resolve many issues that cause a frozen/unresponsive screen. Follow these steps to perform a hard reset:

1. Remove any USB devices from the USB ports of the HMI PC if non-default USB devices were inserted. The USB connection from touch screen should remain.
2. Turn off the computer by pressing and holding the power button for a few seconds.



3. Turn on the PC by pressing the Power button.
4. Wait until HMI application starts up
5. Check if touch screen is responsive and all connected analyzers are shown on Overview screen

NOTE

When this occurs, the system will continue to monitor gas.

Filter Compatibility

When monitoring non-corrosive target gases, use filter type A, (P/N 780248), a sample line dust/particulate filter.

For monitoring corrosive gases, such as chlorine (Cl₂), hydrogen fluoride (HF), hydrogen chloride (HCl), and hydrogen bromide (HBr), sample lines in a dusty environment or for outdoors, use filter type B, (P/N 1830-0055), or type C, (P/N 1991-0147) filter assembly for corrosive gases. The Teflon membrane particulate filter is designed to prevent dust and dirt greater than one micron from entering the sample line. Unlike standard particulate filters, it does not exhibit sample loss with corrosive monitoring.

The one micron Teflon membrane contained in the Filter B housing (P/N 0235-1072, 100 per pack) should be replaced every 30 days.

Filters have an arrow on the side of the filter pointing in the direction of airflow toward the Vertex Edge System. Replacement of filters is site dependent.

Filter A - P/N 780248 Filter B - P/N 1830-0055 Filter C - P/N 1991-0147

The following table shows sample filter requirements.

Symbol	Gas Name	Filter Type A	Filter Type B	Filter Type C
NH ₃	Ammonia		X	X
AsH ₃	Arsine	X		
AsH ₃	Arsine - Low Level	X		
BF ₃	Boron Trifluoride		X	X
CL ₂	Chlorine		X	X
B ₂ H ₆	Diborane	X		
DMA	Dimethylamine		X	X
F ₂	Fluorine		X	X
GeH ₄	Germane	X		
H ₂ S	Hydrogen Sulfide	X		
H ₂ S-LL	Hydrogen Sulfide - Low Level		X	X
HBr	Hydrogen Bromide		X	X
HBr-LL	Hydrogen Bromide - Low Level		X	X
HCl	Hydrogen Chloride		X	X
HCl	Hydrogen Chloride - Low Level		X	X
HCN	Hydrogen Cyanide	X		

Symbol	Gas Name	Filter Type A	Filter Type B	Filter Type C
HF	Hydrogen Fluoride		X	X
HF-LL	Hydrogen Fluoride - Low Level		X	X
H ₂ Se	Hydrogen Selenide	X		
NO ₂	Nitrogen Dioxide	X		
COCl ₂	Phosgene	X		
COCl ₂ /-HL	Phosgene - High Range	X		
PH ₃	Phosphine	X		
SiH ₄	Silane	X		
SO ₂	Sulfur Dioxide		X	X
TDMAT	Tetrakis Dimethylamino Titanium		X	X

Nominal Transport Times

The following table shows the time required for samples to move from the sampling point to the Vertex Edge System for various lengths of sample lines.

OD	0.25" Outside Diameter Tubing				
ID	0.190"(Thin Wall) ID				
Length in feet	100	200	300	327	400
Length in meters	30	61	91	100	122
Sample flow					
1.6	20.5	40.9	61.4	66.9	81.9
2.1	15.6	31.2	46.8	51.0	62.4
2.2	14.9	29.8	44.7	48.7	59.5
2.4	13.6	27.3	40.9	44.6	54.6

Replacement Parts & Consumables

Consumables

Chemcassette	P/N
ALIPHATIC AMINES NH ₃	1295-0221
FLUORINE	1295-0220

Chemcassette	P/N
HYDRIDES	1295-0300
HYDROGEN CYANIDE	1295-0222
HYDROGEN SULFIDE	1295-0223
MINERAL ACIDS	1295-0225
XP CHLORINE (Extended Play)	1295-0227
XP HYDRIDES (Extended Play)	1295-0226
XP PHOSGENE (Extended Play)	1295-0228
XP AMINES/AMMONIA (Extended Play)	1295-0405
XP MINERAL ACIDS (Extended Play)	1295-0507
XP4-V for AMINES/AMMONIA	1257-9309
XP4-V for CHLORINE	1257-9308
XP4-V for HYDRIDES	1257-9300
XP4-V for MINERAL ACIDS	1257-9310
XP4-V for PHOSGENE	1257-9307
XP6-V for Amines/Ammonia	1507-9309
XP6-V for Hydrides	1507-9300

End of Line Particulate Sample Filters	P/N
For non-corrosive gases	780248
For corrosive gases	1830-0055
Replacement membrane, for corrosives (pk/100)	0235-1072
For corrosive gases	1991-0147

Spare Part Numbers	P/N
Closed Loop Optics Block Assembly (4 points) 1295A0607	1502A0148
Optics Cover	1502-0136
Encoder Assembly	1502A0422

Spare Part Numbers	P/N
Encoder Brake Assembly	1295A0091
Encoder Roller	1502-0139
Chemcassette Sprocket	1874-0322
Tape Guide	1295-0026
Microtube Assembly (one point)	1502A0111
Aluminum Gate Actuator Kit	1874K0407
Gate Motor Assembly	1502A0145
Orifice .022	1502-0149
24VDC Fan Assembly	0220-0023
Tubing, FEP Teflon 0.190" (3/16") I.D. x 0.250" (1/4") O.D. - 1000 ft roll (304m)	0235-0109
Tubing, FEP Teflon 0.190" (3/16") I.D. x 0.250" (1/4") O.D - 400 ft roll (121m)	0235-0157
Tubing, Teflon FEP, 3/8" I.D. x 1/2" O.D. - 20 ft roll (6m)	0235-0278
Fan, 230VAC	0220-0028
Ethernet Switch	0185-0086
Fitting, union 1/4 inch	0235-0095
Transformer 480/230 VAC 60 Hz, 5 KVA	0060-1020
Transformer 208/240 VAC 60 Hz, 5 KVA	0060-1021
Needle Valve	0235-1219
Power Distribution Module (complete)	1502A0210
Pump Assy, 220VAC High Flow	1502A0254
Pump Rebuild Kit	0235-1205
Pump Stem and O-Ring	0235-1212
Neoprene Isolation Mount	0950-1061
Thermal Switch (170F)	0170-0082
Fan, 24VDC	0220-0023
Vacuum Fitting Assembly - Exhaust	1295K0547
O RING NO.112 VITON BLUE TEFLON COATED	0235-0187
Unused Point Filter Kit - Inlet Extension with Dust Filter	1295A0702

Spare Part Numbers	P/N
Blocking Plug	0235-1318
Orifice/Filter Assembly	1502A0155

Network Interfaces and Options

Modbus RTU

- Enable or Disable
- Baud rate (User Selectable)
 - 9600
 - 19200 (Default)
- Data bits
 - 8 bits
- Parity (User Selectable)
 - None (Default)
 - Even
 - Odd
- Stop Bits
 - 2
 - 1
- Slave ID option
 - Used for each Analyzer (Default 1-9 as shown)

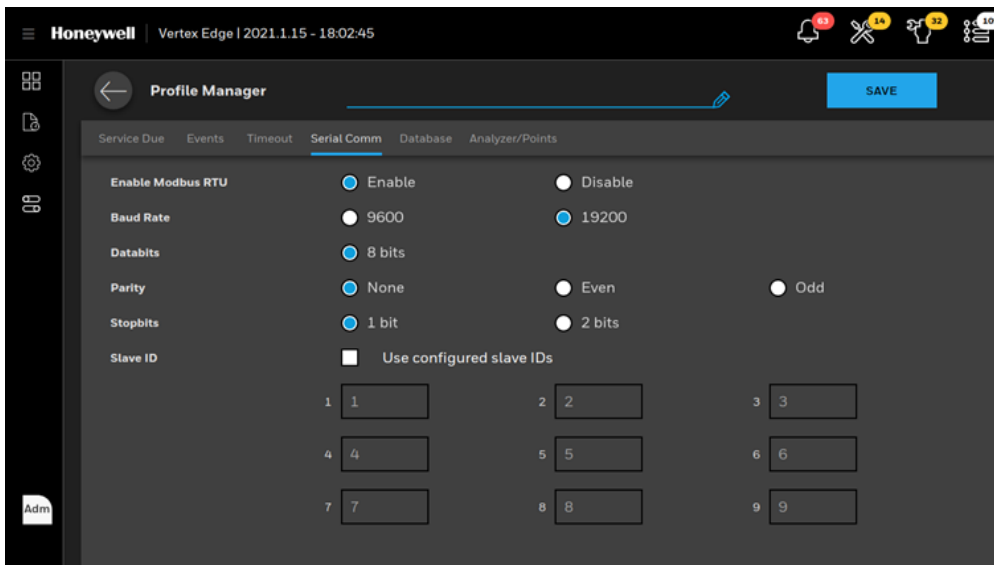



The Modbus RTU Ground Screw is where the equipment needs to be connected for grounding. To maintain data integrity on RS485, connect the shield to ground both ends of the shielded cable.

Modbus TCP/IP and Web interfaces

- IP Configuration
 - DHCP (Default)
 - Static IP: Static IP address, Gateway, DNS
- Modbus TCP/IP Enable or Disable
- Web interface on port 80
 - Enable
 - Disable (Default)
- Encrypted web interface on port 443
 - Enable
 - Disable (Default)

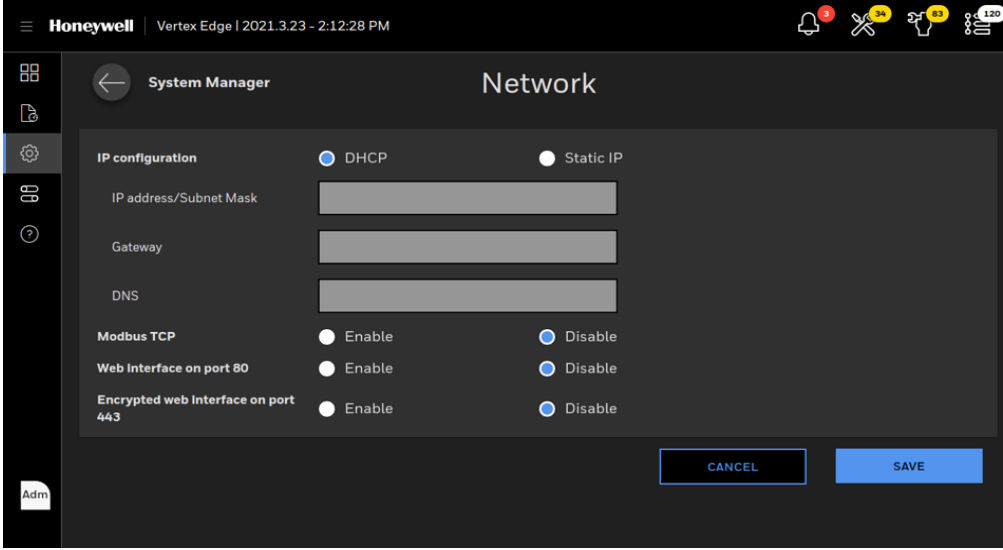

Register Map of Modbus TCP/IP

Register	Hi Byte	Lo Byte	Data Type	Length	Description
40001	Pt 1-1-1 Point Status		Unsigned Integer	1	point enabled, alarm enabled, status of alarm and fault Bit 0: point enabled (0: disabled, 1: enabled) Bit 1 : point inhibited (0: normal, 1: inhibited) Bit 2: Alarm 1 (0: no alarm, 1: in alarm) Bit 3: Alarm 2 (0: no alarm, 1: in alarm) Bit 4: latched alarm 1 (0: no alarm, 1: in alarm) Bit 5: latched alarm 2 (0: no alarm, 1: in alarm) Bit 6: MFault (0: no alarm, 1: in Mfault) Bit 7: IFault (0: no alarm, 1: in Ifault) Bit 8: Sim Alarm 1 (0: no alarm, 1: in alarm) Bit 9: Sim Alarm 2 (0: no alarm, 1: in alarm) Bit 10: over-range (0: no alarm, 1: in over-range) Bit 11: Warning below AL1 (0: no alarm, 1: in warning) Bit 12 ~ 15: Reserved
...	...				
40072	Pt 3-3-8 Point Status		Unsigned Integer	1	
40073	Az 1-1 Flt	Az 1-2 Flt	unsigned integer	1	0: No fault 1: Maintenance Fault 2: Instrument Fault 3: Both faults present A heartbeat counter is provided with some of the fieldbuses in word 76. This increments every second to confirm that communications is working
40074	Az 1-3 Flt	Az 2-1 Flt	unsigned integer	1	
40075	Az 2-2 Flt	Az 2-3 Flt	unsigned integer	1	
40076	Az 3-1 Flt	Az 3-2 Flt	unsigned integer	1	
40077	Az 3-3 Flt	Heartbeat	unsigned integer	1	
40078	Az 1-1 Status		unsigned Integer	1	Analyzer overall status l Bit 0: AZ enable status (0: disabled, 1: enabled) l Bit 1: monitoring status (0: idle, 1: in monitoring mode) l Bit 2: Alarm 1 (0: normal, 1: in gas alarm) l Bit 3: Alarm 2 (0: normal, 1: in gas alarm) l Bit 4: latched alarm 1 (0: normal, 1: in gas alarm) l Bit 5: latched alarm 2 (0: normal, 1: in gas alarm) l Bit 6: MFault (0: normal, 1: in Mfault) l Bit 7: IFault (0: normal, 1: in Ifault) l Bit 8: Sim Alarm 1 (0: normal, 1: in gas alarm) l Bit 9: Sim Alarm 2 (0: normal, 1: in gas alarm) l Bit 10: Sim IFault (0: normal, 1: in Ifault) l Bit 11: Sim MFault (0: normal, 1: in Mfault) l Bit 12: LIT test (0: normal, 1: under testing) l Bit 13: Reserved l Bit 14: Reserved l Bit 15: Reserved
40079	Az 1-2 Status		unsigned Integer	1	
40080	Az 1-3 Status		unsigned Integer	1	
40081	Az 2-1 Status		unsigned Integer	1	
40082	Az 2-2 Status		unsigned Integer	1	
40083	Az 2-3 Status		unsigned Integer	1	
40084	Az 3-1 Status		unsigned Integer	1	
40085	Az 3-2 Status		unsigned Integer	1	
40086	Az 3-3 Status		unsigned Integer	1	
40087	Pt 1-1-1 GasConc		Floating point	2	Little endian
...	

40229	Pt 3-3-8 GasConc		Floating point	2	Little endian
40231	Pt 1-1-1 NormalizedConc		Unsigned Integer	1	Big endian, not used for now
...	
40302	Pt 3-3-8 NormalizedConc		Unsigned Integer	1	Big endian, not used for now
40303	Pt 1-1-1 Flow		Unsigned Integer	1	Little endian
...		
40374	Pt 3-3-8 Flow		Unsigned Integer	1	
40375	Az 1-1 Optics1 Status		unsigned integer	1	Optic Status 5th, 6th byte in optic communication [Low byte] 0x00 No faults 0x01 Watchdog reset 0x02 SW Error (over-range, pointer, buffer overflow, switch-case) 0x04 ADC conversion overflow 0x08 ADC timing overflow 0x10 Post-processing overrun [High byte] 0x00 No faults 0x01 NVM CRC mismatch (at power up and at each access) 0x02 Program CRC mismatch (at power up) 0x04 SPI protocol error 0x08 SPI Tx/Rx overrun 0x10 SPI ISR timeout 0x20 SPI APP timeout
...	...				
40383	Az 3-3 Optics1 Status		unsigned integer	1	
40384	Az 1-1 Optics2 Status		unsigned integer	1	
...	...				
40392	Az 3-3 Optics2 Status		unsigned integer	1	
40393	Az 1-1 Pump1 Status	Az 1-1 Pump2 Status	unsigned integer	1	0: Unknown, 1: Bad, 2: good, 3: Service required
...	...				
40401	Az 3-3 Pump1 Status	Az 3-3 Pump2 Status	unsigned integer	1	0: Unknown, 1: Bad, 2: good, 3: Service required
40402	Az 1-1 active fault code		unsigned integer	1	If no fault, then fault code should be 0x0 If there are active multiple instrument faults, the lowest instrument fault will be returned If there are both instrument and maintenance faults, the lowest instrument fault will be returned
...	...				
40410	Az 3-3 active fault code		unsigned integer	1	
40411	Az 1-1 CCDays		signed integer	1	
...	...				

40419	Az 3-3 CCDays		signed integer	1	
40420	Az 1-1 FilterLife		signed integer	1	
...	...				
40428	Az 3-3 FilterLife		signed integer	1	
40429	Az 1-1 PumpMaintDays		signed integer	1	
...				
40437	Az 3-3 PumpMaintDays		signed integer	1	
40438	Az 1-1 OptMaintDays		signed integer	1	
...				
40446	Az 3-3 OptMaintDays		signed integer	1	
40447	Az 1-1 PtEn	Az 1-2 PtEn	unsigned integer	1	0: Disabled, 1: Enabled. Bitfields. MSB: Pt8, LSB: Pt1
40448	Az 1-3 PtEn	Az 2-1 PtEn	unsigned integer	1	
40449	Az 2-2 PtEn	Az 2-3 PtEn	unsigned integer	1	
40450	Az 3-1 PtEn	Az 3-2 PtEn	unsigned integer	1	
40451	Az 3-3 PtEn	unused	unsigned integer	1	
40452	Pt 1-1-1 AlarmThres1		Floating point	2	R/W (function code 0x10)
...				
40594	Pt 3-3-8 AlarmThres1		Floating point	2	R/W (function code 0x10)
40596	Pt 1-1-1 AlarmThres2		Floating point	2	R/W (function code 0x10)
...				
40738	Pt 3-3-8 AlarmThres2		Floating point	2	R/W (function code 0x10)
40740	Pt 1-1-1 FullScale		Floating point	2	

...	...				
40882	Pt 3-3-8 FullScale	Floating point	2		
40884	Pt 1-1-1 PtName	string[26]	13		Null terminated. Up to 25 characters
...	...				
41807	Pt 3-3-8 PtName	string[26]	13		Null terminated. Up to 25 characters
41820	Pt 1-1-1 GasName	string[26]	13		Null terminated. Up to 25 characters
...	...				
42743	Pt 3-3-8 GasName	string[26]	13		Null terminated. Up to 25 characters
42756	Pt 1-1-1 Decimal	Pt 1-1-2 Decimal	unsigned integer	1	
...			
42791	Pt 3-3-7 Decimal	Pt 3-3-8 Decimal	unsigned integer	1	
42792	Pt 1-1-1 GasUnit	string[6]	3		Null terminated. Up to 5 characters
...	...				
43005	Pt 3-3-8 GasUnit	string[6]	3		Null terminated. Up to 5 characters
43008	Az 1-1 Label	string[26]	13		
...	...				
43112	Az 3-3 Label	string[26]	13		
43125	Az 1-1 GasFamily		Byte	1	
...	...				
43133	Az 3-3 GasFamily		Byte	1	
43134	Az 1-1 Az SW Ver	Byte[3]	2		first byte: major, second byte: minor, last two bytes: build number
...	...				
43150	Az 3-3 Az SW Ver	Byte[3]	2		
43152	Az 1-1 Ctrl SW Ver	Byte[3]	2		first byte: major, second byte: minor, last two bytes: build number
...	...				
43168	Az 3-3 Ctrl SW Ver	Byte[3]	2		
43170	Az 1-1 Opt1 SW Ver		Byte[3]	2	first byte: major, second byte: minor, last two bytes: build number

...	...				
43186	Az 3-3 Opt1 SW Ver		Byte[3]	2	
43188	Az 1-1 Opt2 SW Ver		Byte[3]	2	first byte: major, second byte: minor, last two bytes: build number
...	...				
43204	Az 3-3 Opt2 SW Ver		Byte[3]	2	
43206	Az 1-1 CC SN		string[26]	13	Null terminated. Up to 25 characters
...	...				
43310	Az 3-3 CC SN		string[26]	13	Null terminated. Up to 25 characters
43323	Az 1-1 Serial Number		string[26]	13	Null terminated. Up to 25 characters
...	...				
43427	Az 3-3 Serial Number		string[26]	13	Null terminated. Up to 25 characters
43440	Az 1-1 PDU ID		string[26]	13	Can be used same as rack ID. Null terminated. Up to 25 characters
...				
43544	Az 3-3 PDU ID		string[26]	13	Null terminated. Up to 25 characters
43557	Az 1-1 PDU SW Ver		Byte[3]	2	First byte: major, second byte: minor, last two bytes: build number
...	...				
43573	Az 3-3 PDU SW Ver		Byte[3]	2	
43575	HMI SW Ver		Byte[3]	2	First byte: major, second byte: minor, last two bytes: build number
65001	Az 1-1 Reset alarms & faults		Unsigned Integer	1	Nonzero value
...					
65009	Az 3-3 Reset alarms & faults		Unsigned Integer	1	Nonzero value

Register	Hi Byte	Lo Byte	Data Type	Length	Description
40001	Pt 1 Status		Unsigned Integer	1	point enabled, point inhibited, status of alarm and fault Bit 0: point enabled (0: disabled, 1: enabled) Bit 1 : point inhibited (0: normal, 1: inhibited) Bit 2: Alarm 1 (0: no alarm, 1: in alarm) Bit 3: Alarm 2 (0: no alarm, 1: in alarm) Bit 4: latched alarm 1 (0: no alarm, 1: in alarm) Bit 5: latched alarm 2 (0: no alarm, 1: in alarm) Bit 6: MFault (0: no alarm, 1: in Mfault) Bit 7: IFault (0: no alarm, 1: in Ifault) Bit 8: Sim Alarm 1 (0: no alarm, 1: in alarm) Bit 9: Sim Alarm 2 (0: no alarm, 1: in alarm) Bit 10: over-range (0: no alarm, 1: in over-range) Bit 11: Warning below AL1 (0: no alarm, 1: in warning) Bit 12 ~ 15: Reserved Single Analyzer information is

...	...					
40008	Pt 8 Status	Unsigned Integer	1	available		
40009	Az Status	Unsigned Integer	1	Analyzer overall status l Bit 0: AZ enable status (0: disabled, 1: enabled) l Bit 1: monitoring status (0: idle, 1: in monitoring mode) l Bit 2: Alarm 1 (0: normal, 1: in gas alarm) l Bit 3: Alarm 2 (0: normal, 1: in gas alarm) l Bit 4: latched alarm 1 (0: normal, 1: in gas alarm) l Bit 5: latched alarm 2 (0: normal, 1: in gas alarm) l Bit 6: MFault (0: normal, 1: in Mfault) l Bit 7: IFault (0: normal, 1: in Ifault) l Bit 8: Sim Alarm 1 (0: normal, 1: in gas alarm) l Bit 9: Sim Alarm 2 (0: normal, 1: in gas alarm) l Bit 10: Sim IFault (0: normal, 1: in Ifault) l Bit 11: Sim MFault (0: normal, 1: in Mfault) l Bit 12: LIT test (0: normal, 1: under testing) l Bit 13: Reserved l Bit 14: Reserved l Bit 15: Reserved		
40010	Az Flt	Heartbeat	unsigned integer	1	0: No fault 1: Maintenance Fault 2: Instrument Fault 3: Both faults present A heartbeat counter is provided with some of the fieldbuses in word 9. This increments every second to confirm that communications is working	
40011	Pt 1 GasConc	Floating point	2			
...			
40025	Pt 8 GasConc	Floating point	2			
40027	Pt 1 NormalizedConc	Unsigned Integer	1			
...	Not used for now		
40034	Pt 8 NormalizedConc	Unsigned Integer	1			
40035	Pt 1 Flow	Unsigned Integer	1			
...	...			cc/min		
40042	Pt 8 Flow	Unsigned Integer	1			
40043	Az Optics1 Status	Unsigned integer	1		Optic Status 5th, 6th byte in optic communication [Low byte] 0x00 No faults 0x01 Watchdog reset 0x02 SW Error (over-range, pointer, buffer overflow, switch-case) 0x04 ADC conversion overflow 0x08 ADC timing overflow 0x10 Post-processing overrun [High byte] 0x00 No faults 0x01 NVM CRC mismatch (at power up and at each access) 0x02 Program CRC mismatch (at power up) 0x04 SPI protocol error 0x08 SPI Tx/Rx overrun 0x10 SPI ISR timeout 0x20 SPI APP timeout	
40044	Az Optics2 Status	Unsigned integer	1			
40045	Az Pump1 Status	Az Pump2 Status		1	0: Unknown, 1: Bad, 2: good, 3: Service required	
40046	Az active fault code	unsigned integer	1		if no fault, then fault code should be 0x0 If there are active multiple instrument faults, the lowest instrument fault will be returned If there are both instrument and maintenance faults, the lowest instrument fault will be returned	
40047	Az CCDays	signed integer	1			
40048	Az FilterLife	signed integer	1			

40049	Az PumpMaintDays		signed integer	1	
40050	Az OptMaintDays		signed integer	1	
40051	Az PtEn	unused	unsigned integer	1	0: Disabled, 1: Enabled. Bitfields. MSB: Pt8, LSB: Pt1
40052	Pt 1 AlarmThres1		Floating point	2	Single Analyzer information is available
...				
40066	Pt 8 AlarmThres1		Floating point	2	
40068	Pt 1 AlarmThres2		Floating point	2	Single Analyzer information is available
...				
40082	Pt 8 AlarmThres2		Floating point	2	
40084	Pt 1 FullScale		Floating point	2	Single Analyzer information is available
...				
40098	Pt 8 FullScale		Floating point	2	
40100	Pt 1 PtName		string[26]	13	null terminated. Up to 25 characters
...				
40191	Pt 8 PtName		string[26]	13	
40204	Pt 1 GasName		string[26]	13	null terminated. Up to 25 characters
...				
40295	Pt 8 GasName		Floating point	13	
40308	Pt 1 Decimal	Pt 2 Decimal	unsigned integer	1	
...				
40311	Pt 7 Decimal	Pt 8 Decimal	unsigned integer	1	
40312	Pt 1 GasUnit		string[6]	3	null terminated. Up to 5 characters Based on measurement unit it should provide unit strings as below. 0: ppb, 2: %Lel, 4: mg/m3, 8: ppm, 12: %Vol
...				
40333	Pt 8 GasUnit		string[6]	3	
40336	Az Label		string[26]	13	

40349	Az GasFamily	unused	Byte	1	
40350	Az SW Ver		Byte[3]	2	First byte: major, second byte: minor, last two bytes: build number
40352	Ctrl SW Ver		Byte[3]	2	First byte: major, second byte: minor, last two bytes: build number
40354	Opt1 SW Ver		Byte[3]	2	First byte: major, second byte: minor, last two bytes: build number
40356	Opt2 SW Ver		Byte[3]	2	First byte: major, second byte: minor, last two bytes: build number
40358	Az CC SN		string[26]	13	Null terminated. Up to 25 characters
40371	Az Serial Number		string[26]	13	Null terminated. Up to 25 characters
40384	Az PDU ID		string[26]	13	Can be used same as rack ID. null terminated. Up to 25 characters
40397	Az PDU SW Ver		Byte[3]	2	First byte: major, second byte: minor, last two bytes: build number
65001	Az Reset alarms & faults		Unsigned Integer	1	Nonzero value

HMI PC Security Considerations

Connectivity

The Vertex Edge HMI PC has two one-gigabit ethernet ports, one for connecting to the internal analyzer network, and one for connecting to an external network. The Vertex Edge HMI PC has no wireless connectivity.

Internal Network

The internal analyzer network is 192.168.254.10x/24, and the HMI PC has the address 192.168.254.1 on this network. Only connect analyzers and the HMI PC to this internal network; Do not connect any other device.

External Network

The connection to the external network is not required but enables additional features, including remote web access and the Modbus TCP server. These services are disabled by default but can be enabled via the General > Network configuration page. The default configuration of the Vertex Edge HMI PC external network connection is via DHCP. However, if desired, a static configuration is possible via the General > Network configuration page. Care should be taken both in DHCP server configuration as well as in the static configuration that the network assigned to the external connection, and that does not overlap with the internal analyzer network.

Vertex Edge HMI External Network Services

Service	Port	Transport Protocol	Default Setting
HTTP	80	TCP	OFF
HTTPS	443	TCP	OFF
Modbus TCP	502	TCP	OFF

NOTE

Chrome browser of 93.0.xx or later version is strongly recommended to access to the HMI remotely.

NOTE

When the web interface is enabled/used, the encrypted interface on port 443 is strongly recommended since HTTP web service is not secure.

HTTPS Connections

When making a connection to the Vertex Edge HMI PC via HTTPS, it will be necessary to accept the certificate. A message like the one using Google Chrome will be shown:

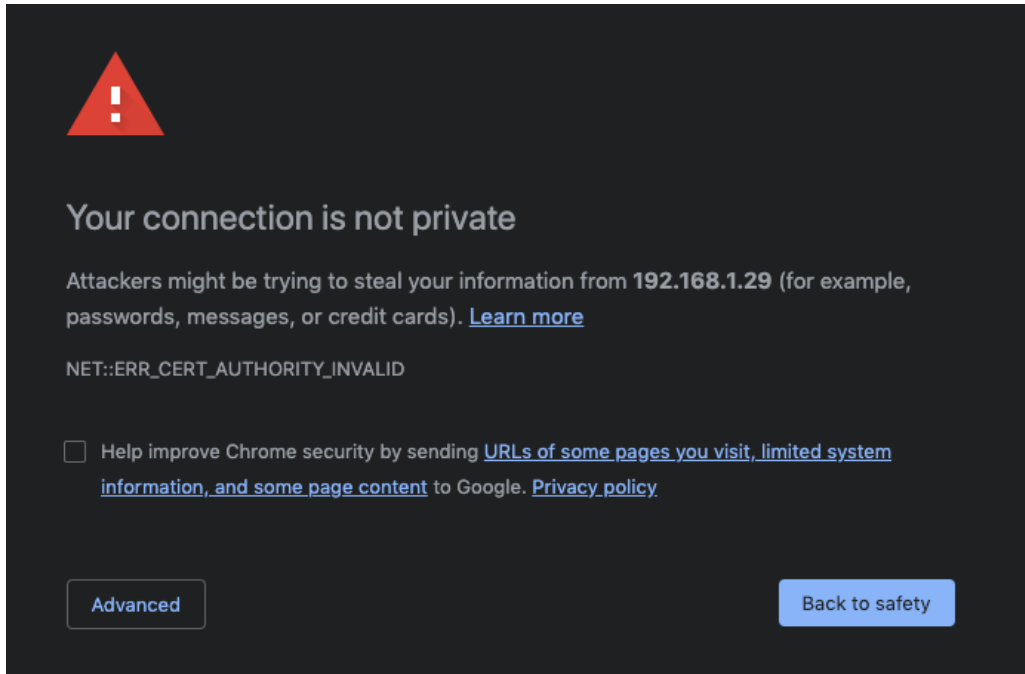

Tap on the **Advanced** button, and select “Proceed to <some IP> (unsafe).”

External Network Security Considerations

The Vertex Edge HMI PC is intended ONLY for connection to a private network – no connections from the internet should be allowed. All services not explicitly named above are disabled and filtered via the iptables rules. Access control is via users and roles defined in the security configuration. By default, anyone can view system state information, but elevated permissions are required for any configuration, control, or maintenance.

NOTE

Router with IPSec is recommended to secure Modbus TCP/IP communication in an insecure network.

Warranty Statement

All products are warranted by Honeywell International Inc (herein referred to as 'Honeywell') to be free from defects in material or workmanship under normal use and service for a period of twelve (12) months after start-up or eighteen (18) months after shipment.

Honeywell limited warranty only extends to the sale of new and unused products to the original buyer if the products were purchased from Honeywell or from a Honeywell distributor, dealer or representative. When, in the opinion of Honeywell, a warranty claim is valid, Honeywell will repair or replace the defective product free of charge and send it or any replacement back to the buyer. A warranty claim will only be accepted if a proof of purchase is submitted and all conditions contained within this Warranty are met.

Conditions

The obligations set forth in this warranty are conditional on:

- a) proper storage, installation, calibration, use, maintenance and compliance with the product manual instructions and any other applicable recommendations of Honeywell; and
- b) the buyer promptly notifying Honeywell of any defect and, if required, promptly making the product available for correction. No goods shall be returned to Honeywell until receipt by the buyer of shipping instructions from Honeywell.

Warranty Return Process:

When the buyer wishes to return a product under warranty, the buyer must obtain a Service Order Number from Honeywell and if practical return the product clearly marked with the Service Order Number and a full description of the fault at buyer's expense. If no description of the fault is provided, Honeywell reserves the right to charge an investigation fee. If the product is found to be of "no fault", Honeywell reserves the right to charge an investigation fee and return same product to buyer after the investigation fee and transport cost are reimbursed in full. The investigation fee in both cases will not exceed \$320. In the case of a fixed installation or where it is not practical to return the product, the buyer must submit a written claim to Honeywell's Service Department. A service engineer will attend on site on a day rate basis. Where a valid warranty claim is identified, the faulty product will be repaired or replaced free of charge but in all cases the day rate charge will apply. If, in the course of investigation Honeywell determines that recalibration of the instrument is required, Honeywell will recalibrate the instrument and calibration charges will apply. In no event shall Honeywell's liability exceed the original purchase price paid by the buyer for the product.

Exclusions:

Excluded from any warranty claim is any product, which in Honeywell's opinion, has been misused, altered, neglected or damaged by accident or abnormal conditions of operation, handling or use, defects attributable to improper installation including but not limited to: Physical damage, warping to the main PCB as a result of crushing, component or board damage at a point of impact or as a result of dropping of the unit from above the stated certification height, fluid ingress as a result of submergence beyond the I.P. rating specification, poisoning or inhibition of sensor, any damage or defects attributable to repair of the product by any person other than an authorized dealer or Honeywell's affiliate within the Honeywell group or installation of unapproved parts on the product. Excluded are consumable items such as dry-

cell batteries, filters and fuses or routine replacement parts due to the normal wear and tear of the product. After the effective date this warranty supersedes all existing warranty statements and Honeywell makes no other warranty expressed or implied except as stated above.

Contact Us

Honeywell Analytics

405 Barclay Boulevard

Lincolnshire, Illinois

60069, USA

is.gas.techsupport@honeywell.com

Tel: +1 847 955 8200

Toll free: +1 800 538 0363



Scan this code for further
reference to Vertex Edge Systems
on Honeywell Analytics website



© January, 2022

1998-2000_EN_RevA2_VertexEdge_UserManual



DETECTION | **S**AFETY | **P**ROTECTION

For Pricing or Further
Information Please Contact Us.



+441158390495



www.manonglobal.com



sales@manonglobal.com

**Leading UK Suppliers In
Gas Detection, Safety & Protection
Products
Brand New & Genuine OEM Parts
UK & Worldwide Deliveries Available**



Worldwide Delivery



1000+ Genuine Parts & Equipment