

## Multi-Purpose Detector (MPD)

## Table of Contents

<b>Safety</b> .....	<b>5</b>
<b>1. Introduction</b> .....	<b>8</b>
1.1.1 Naming Conventions .....	8
<b>1.2 Principle of Operation</b> .....	<b>9</b>
1.2.1 Catalytic Bead Sensor MPD-**-CB1.....	9
<b>1.3 Accessories</b> .....	<b>9</b>
1.3.1 Collecting Cone .....	10
1.3.2 Weatherproof Cap.....	10
1.3.3 Sample / Calibration Gas Flow Adaptor .....	11
1.3.4 Gassing Point Assembly .....	11
1.3.5 Duct Mount Kit.....	12
1.3.6 Filters .....	12
<b>2. Installation</b> .....	<b>13</b>
<b>2.1 Unpacking</b> .....	<b>13</b>
<b>2.2 Sensor Orientation</b> .....	<b>13</b>
<b>2.3 MPD Remote Mount</b> .....	<b>13</b>
<b>2.4 Wiring</b> .....	<b>14</b>
<b>2.4 Cable Connections</b> .....	<b>14</b>
<b>2.5 Fitting Sensors</b> .....	<b>15</b>
<b>3. Fitting Accessories</b> .....	<b>16</b>
<b>3.1 Collecting Cone</b> .....	<b>16</b>
<b>3.2 Weatherproof Cap</b> .....	<b>16</b>
<b>3.3 Sample/Calibration Gas Flow Adaptor</b> .....	<b>16</b>
<b>3.4 Filters</b> .....	<b>16</b>
<b>3.5 Duct Mount Kit</b> .....	<b>16</b>
<b>4. Maintenance</b> .....	<b>17</b>
<b>4.1 General</b> .....	<b>17</b>
<b>4.2 Cleaning</b> .....	<b>17</b>
<b>5. Faults</b> .....	<b>18</b>
<b>6. Functional Gas Test (Bump Test)</b> .....	<b>19</b>
<b>6.1 Sensor without Accessories</b> .....	<b>19</b>
<b>6.2 Sensor with Collecting Cone or Weatherproof Cap</b> .....	<b>19</b>
<b>6.3 Sensor with Sample/Calibration Gas Flow Adaptor</b> .....	<b>19</b>
<b>7. Calibration</b> .....	<b>20</b>
7.1 Zero and Span Calibration for MPD Sensors with XNX Universal Transmitter .....	20
<b>7.2 Cross Calibration procedure for MPD-CB1</b> .....	<b>22</b>
<b>7.3 MPD-CB1 Flammable Sensor Operational Life</b> .....	<b>24</b>
<b>7.4 Meter Multiplication Factors for MPD-IF1</b> .....	<b>24</b>
<b>8. Replacement Parts</b> .....	<b>25</b>

---

<b>8.1 MPD Catalytic Bead and IR Replacement Sensor Cartridges</b>	<b>25</b>
<b>8.2 Terminal Housings</b>	<b>25</b>
<b>8.3 Maintenance Spares</b>	<b>25</b>
<b>8.4 MPD Calibration Gases</b>	<b>26</b>
<b>9. Specifications</b>	<b>26</b>
<b>9.1. General Specifications</b>	<b>26</b>
<b>9.2 Performance Data</b>	<b>26</b>
<b>9.3 MPD-CB1</b>	<b>28</b>
9.2.1 MPD-CB1 Cross Sensitivity	28
<b>9.4 MPD-IV1</b>	<b>29</b>
<b>9.5 MPD-IF1</b>	<b>30</b>
<b>9.6 MPD-IC1</b>	<b>31</b>
<b>9.7 MPD Certifications by Part Number Series</b>	<b>32</b>
9.7.1 MPD Certification Labels	33
<b>10. Warranty</b>	<b>34</b>
<b>11. EC Declaration of Conformity</b>	<b>36</b>

---

## Safety

- » Ensure that this Operating Manual is read and understood **BEFORE** installing, operating, or maintaining the equipment.
- » Pay particular attention to Warnings and Cautions.
- » All document Warnings and Cautions are listed here and repeated where appropriate in the relevant chapter(s) of this Operating Manual.



### **WARNINGS**

- » Agency approvals are associated with specific Sensor/Housing combinations prohibiting field upgrade of sensor types. The MPD part number, serial number, sensor type and target gas should be provided when ordering replacement sensors (See Section 8.1 MPD Catalytic Bead and IR Replacement Sensor Cartridges).
- » High off-scale readings may indicate an explosive concentration of gas.
- » To maintain safety standards, regular maintenance, calibration and operation of this equipment by qualified personnel is essential. Read and understand this manual completely before operating or servicing. If any further details are required which do not appear in this manual contact Honeywell Analytics or their agent.
- » The Code of Practice regarding 'Selection, Installation and Maintenance of Electrical Apparatus for use in Potentially Explosive Atmospheres' must be complied with at all times. Refer to the appropriate local or national regulations relative to the installation site. Elsewhere the appropriate local and/or national regulations should be used.
- » As some test gases may be hazardous, the Flow Adaptor outlet should exhaust into a safe area.
- » Operators must be fully aware of the action to be taken if the gas concentration exceeds an alarm level.
- » Before installing the sensors, isolate the power supply by disconnecting or removing the associated control module from the installation.
- » Appropriate care should be taken when handling cylinders of compressed flammable and toxic gases during calibration and bump testing.



## CAUTIONS

- » To maintain safety standards, regular maintenance, calibration and operation of the equipment by qualified personnel is essential.
- » Do not modify or alter the sensor construction as essential safety requirements may be invalidated.
- » When replacing sensors, dispose of used sensors in accordance with local disposal regulations. For more information on sensor disposal, contact your HA Representative.
- » The catalytic detector element is resistant to catalyst poisons, however, abnormally high concentrations of halogenated hydrocarbons, vapors of heavy metals or compounds, some silicone compounds and sulfur compounds may cause loss of sensitivity.
- » The MPD must never be used in conditions where there is insufficient oxygen to totally oxidize the combustible gas. For most combustible gases, an oxygen level of at least 15% is sufficient.
- » The sintered disc on the sensor assembly must be kept free from contaminants; i.e. oil and dirt.
- » The sensitivity of catalytic sensors is impaired by silicone compounds. Do not expose the sensors to silicones or silicone-based products.
- » The relevant site procedures must be obeyed at all times when opening the Terminal Housing or removing the sensor in a hazardous areas.
- » The sensitivity of Catalytic Sensors is impaired by silicone compounds. Do not expose to silicones or silicone based products.
- » Dismantling of a sensor or a sensor installation by other than authorized engineers invalidates certification.
- » Upward pressure on the gassing nozzle of the Weatherproof Cap forces the nozzle against the sinter. Rotation of the nozzle may damage the sinter if a filter is not fitted.
- » Direct gassing of the sensor via the nozzle on the Collecting Cone in wind speeds of greater than 5 meters per second may cause errors.
- » The calibration procedure should only be performed by qualified personnel.
- » Before initial calibration allow the detector to stabilize for 30 minutes after applying power. When in zero and span calibration mode the current output from the detector is inhibited (e.g. default 2mA) to avoid false alarms.
- » Extended or frequent exposure to elevated concentrations of combustible gases may affect sensor sensitivity. Verify sensor performance by frequent calibration.
- » Where the user calibrates any sensor using a different gas, responsibility for identifying and recording calibration rests with the user. Refer to the local regulations where appropriate.
- » These (meter multiplication) factors only apply to gas concentrations expressed in % Volume terms.

- 
- » When using a linear cross reference factor the temperature compensation is based upon propane, and there may be errors at temperatures away from the calibration temperature.
  - » To maintain safety standards, regular maintenance, calibration and operation of the equipment by qualified personnel is essential.
  - » Do not modify or alter the sensor construction as essential safety requirements may be invalidated.
  - » When replacing sensors, dispose of used sensors in accordance with local disposal regulations. For more information on sensor disposal, contact your HA Representative.

### **ATEX Temperature Code Ratings**

- » Component gets no hotter than an operating temperature code of T4 when installed according to the electrical specifications of Label ( Sch Drawing 1226E0309)
- » Maximum surface temperatures is less than 85°C when measured under normal operating conditions for the Dust evaluation.

### **Important Notices**

Every effort has been made to ensure the accuracy of the contents of our documents, however, Honeywell Analytics can assume no responsibility for any errors or omissions in our documents, or their consequences.

Honeywell Analytics can take no responsibility for installation and/or use of its equipment if this is not done in accordance with the appropriate issue and/or amendment of the manual.

The user of this manual should ensure that it is appropriate in all details to the exact equipment to be installed and/or operated. If in doubt, the user should contact Honeywell Analytics for advice.

If further details are required which do not appear in this manual, contact Honeywell Analytics or one of their agents.

---

## 1. Introduction

The MPD (Figure 1) is a serviceable explosion proof housing, offered with either catalytic bead or infrared sensors for the measurement of flammable and toxic gases. The assembly is constructed of 316 stainless steel and is supplied in either ¾ inch NPT or M25 thread versions with corresponding approvals (See Section 10 - Specifications). The sinter assembly can easily be removed for same sensor replacement.



### **WARNING:**

**Agency approvals are associated with specific Sensor/Housing combinations prohibiting field upgrade of sensor types. The MPD part number, serial number, sensor type and target gas should be provided when ordering replacement sensors (See Section 8.1 MPD Catalytic Bead and IR Replacement Sensor Cartridges).**

The MPD can be mounted directly to a transmitter such as the XNX Universal Transmitter or other suitable device in a hazardous area, or remotely mounted to a transmitter located in a non-hazardous area. For remote mounting, the detector is fitted to an optional junction box. The ¾ NPT type is supplied with factory sealed leads eliminating the need for a pour gland between the detector and the junction box.

Optional accessories such as collecting cone, weatherproof cap or alternative sampling systems can be installed to the MPD via the M40 external thread provided on the sensor retainer. A M40 (female) to M36 (male) adaptor can be ordered, offering additional accessory selections.

The presence of target gas is indicated via a millivolt electrical interface for all sensor types via three wires. Two additional wires provide a digital interface for the infrared version. When appropriately interfaced with a controller, the controller can provide outputs such as display, 20mA, relay, etc.

The MPD detector must be installed in accordance with local and national requirements for the installed area and application. Reference drawing number 1226E0351 for specific installation requirements.

Honeywell recommends periodic bump testing of the sensor to ensure proper operation and compliance with the functional safety rating of the installation.

### 1.1.1 Naming Conventions

MPD sensor models are in the format MPD-XX-YYY. XX designates agency approval (AM = ATEX/IEC Ex with male M25 thread, UT = UL/CSA or UL with male ¾" NPT thread, BT = UL/INMETRO with male ¾" NPT thread), YYY designates the sensor Type (CB1 = Catalytic bead % LEL, IF1 = Infrared % LEL, IV1 = Infrared % LEL CH<sub>4</sub>, IC1 = Infrared CO<sub>2</sub>).

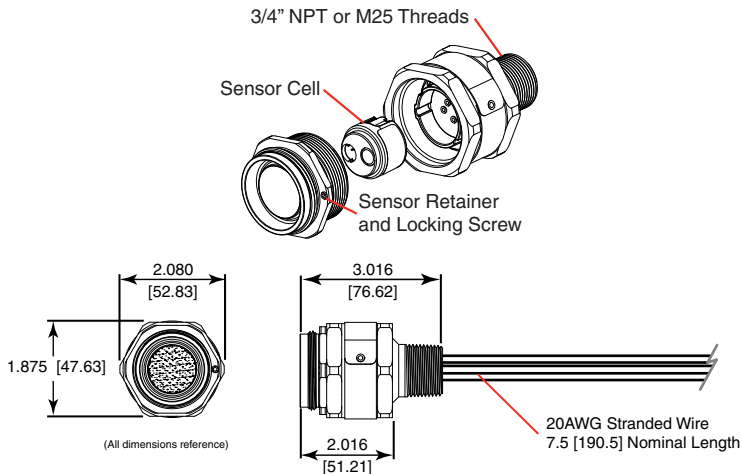

Figure 1. Multi-Purpose Detector (MPD)

## 1.2 Principle of Operation

### 1.2.1 Catalytic Bead Sensor MPD-\*\*-CB1

The CB1 sensor, catalytic bead type contains two elements which are heated by a defined constant electrical current from the transmitter. One element is sensitive to the presence of combustible gas, the second element compensates for changes in temperature. When a combustible gas is present, the sensing element temperature increases due to catalytic oxidation of the gas. The resistance of the element is proportional to temperature and is proportional to a change to gas concentration. The catalytic bead sensor provides the broadest range of combustible detection, widest temperature range and performance approvals.

### 1.2.2 Infrared Sensor MPD-\*\*-IF1, IV1, IC1

The IF1, IV1 and IC1 sensors use **Non-Dispersive InfraRed (NDIR)** Adsorption techniques to detect a gas or family of gases. The sensor cells contain a long life tungsten filament infrared light source, an optical cavity into which gas diffuses, a dual temperature compensated pyroelectric infrared detector, and integral semiconductor temperature sensor and electronics to process the signals from the pyroelectric detector.

The IV1 sensor can measure methane concentration in the range of 0-5%Vol or 0-100%LEL. The IF1 sensor can measure propane concentration in the range of 0-100%LEL. The IC1 is used for carbon dioxide monitoring in the range of 0-5% Vol.

## 1.3 Accessories

The following accessories are available for use with the sensors:

- a. Collecting Cone (Figure 3).
- b. Weatherproof Cap (Figure 4).
- c. Sample/Calibration Gas Flow Adaptor (Figure 5).
- d. Remote Gassing Port (Figure 6).
- e. Duct Mount Kit (Figure 7).
- f. Filters

---

### 1.3.1 Collecting Cone

(02000-A-1642)

The detection of a lighter than air gas is enhanced by the use of a Collecting Cone. The cone fits onto the Sensor accessory thread in place of the Filter Housing and retains the filter. The appropriate filter must be fitted.

A nozzle on the cone permits gassing of the Sensor with the cone in position. Test gas is applied either direct to the nozzle or via a permanently connected pipe-line when the Sensor is in an inaccessible location.

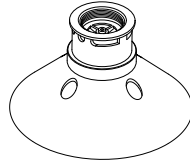

Figure 2. Collecting Cone

### 1.3.2 Weatherproof Cap/Housing

(Cap: 02000-A-1640, Housing: SPXCDWP)

The Weather Protection Housing, fitted to a sensor installed in an exposed location, affords protection from driving rain from vertical to 30° below horizontal. When mounted close to the ground, protection is afforded from heavy rain rebounding off the ground. It also reduces contamination from industrial waste and enables the application of test gas in high wind speeds without significant error.

Incorporated in the housing is a nozzle to facilitate gassing of the sensor with the Weather Protection Housing in position, either by direct application to the nozzle or via a permanently connected pipeline. On the Weatherproof Cap (02000-A-1640), the nozzle is free to rotate within the housing to allow removal from the sensor without disconnecting a permanently connected pipeline, when changing the Hydrophobic Barrier and cleaning the sensor.

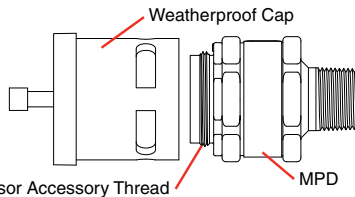

Figure 3. MPD, Adaptor and Weatherproof Cap



Figure 4. Weatherproof Housing

---

### 1.3.3 Sample / Calibration Gas Flow Adaptor

(1226A0411)

A Flow Adaptor provides a facility to allow sampling of a closed system by means of two pipelines. The Flow Adaptor is fitted to the sensor accessory thread by a locking ring that enables the Flow Adaptor to be removed without disconnecting the pipeline. The Filter is retained by the Flow Adaptor and interfaces with a gasket bonded to the Flow Adaptor. The Flow Adaptor ports are designed to be fitted with 1/4 in (6mm) soft tubing.

The Flow Adaptor is also used to apply calibration gas to the sensor. See Section 7 - Calibration for further details on calibrating the detector.

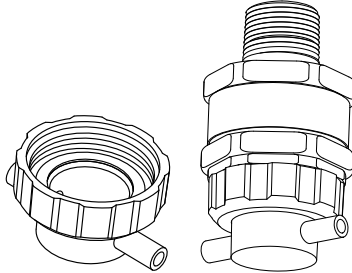

Figure 5. Flow Adaptor / MPD with Flow Adaptor

### 1.3.4 Gassing Point Assembly

(1226A0354)

The Gassing Point Assembly assembly can be fixed in a convenient position and permanently connected by suitable tubing to an inaccessible sensor, thus simplifying the application of test gas when checking sensor calibration. A DIN Rail Mounting Assembly (00785-A-0069) is available to enable five gassing point assemblies to be mounted side by side.

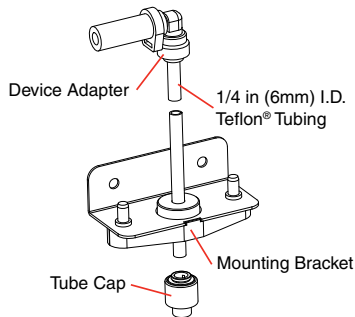

Figure 6. Remote Gassing Port

---

### 1.3.5 Duct Mount Kit

The duct mounting kit (S3KDMK), combined with the MPD Interface Adaptor (1226A0382), can accommodate the MPD to detect flammable gases in a duct application. The duct mount kit includes the adaptor, gasket and required fasteners. The MPD Interface Adaptor includes only the adaptor and requires the S3KDMK duct mount kit.

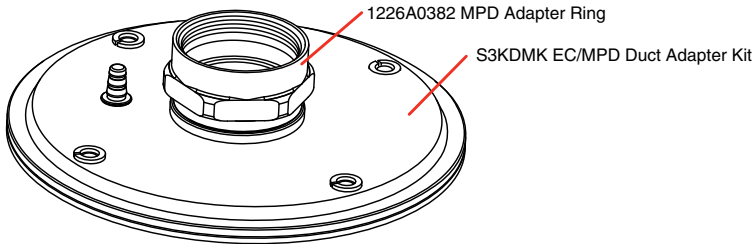

Figure 7. Duct Mount Kit

### 1.3.6 Filters

In a clean atmosphere, and where no accessories are to be fitted, a filter is not needed. It is however mandatory that a filter should be fitted to provide protection appropriate to the environment and to complete the seal when a Weatherproof Cap or Collecting Cone is fitted.

---

## 2. Installation



### WARNING

The Code of Practice regarding 'Selection, Installation and Maintenance of Electrical Apparatus for use in Potentially Explosive Atmospheres' must be complied with at all times. Refer to the appropriate local and/or national regulations relative to the installation site. Elsewhere the appropriate local and/or national regulations should be used.



### CAUTIONS

The catalytic detector element is resistant to catalyst poisons, however, abnormally high concentrations of halogenated hydrocarbons, vapors of heavy metals or compounds, some silicone compounds and sulfur compounds may cause loss of sensitivity.

The MPD must never be used in conditions where there is insufficient oxygen to totally oxidize the combustible gas. For most combustible gases, an oxygen level of at least 15% is sufficient.

The sintered disc on the sensor assembly must be kept free from contaminants; i.e. oil and dirt.

### 2.1 Unpacking

On receipt the equipment must be carefully unpacked, observing any instructions printed on the packaging, and the contents checked for deficiencies and transit damage.

### 2.2 Sensor Orientation

The sensor must be installed with the Sensor facing downwards. For MPD-BT-IC1 and MPD-UT-IC1 performance approval, the supplied SPXCDWP weather protector must be installed in order to meet published performance standards. In environments requiring IP66 protection, the SPXCDWP must be fitted.

### 2.3 MPD Remote Mount

The MPD can be remote mounted using an approved junction box and interconnecting conduit or cabling. The Junction Box and installation must be in compliance with all local requirements for the area in which the unit is installed.

- The MPB UT versions must be installed a minimum of 5 1/4 turns into the Junction box or Transmitter to maintain approval rating.
- The MPD Leads are factory sealed, which relieves the requirement for a pour fitting between the junction box and sensor.

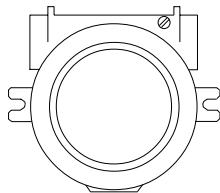

UL/CSA Aluminum Junction Box  
2441-0022

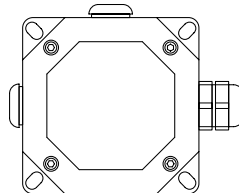

ATEX/IEC Junction Box  
00780-A-0100

Figure 8. Terminal Housings

---

## 2.4 Wiring

### NOTE:

To maintain EMC integrity, wiring must be shielded by either an integral shield or run through conduit or pipe. Shield should provide 90% coverage.

The MPD Sensor must be operated from a transmitter supplied by a Class 2 Power Supply.

For remote sensor installations, ensure the resistance of the wire is considered in the interface of the sensor to maintain proper operation. For XNX the following values should not be exceeded:

AWG	Metric Wire Gauge (mm <sup>2</sup> )	MPD CB1 Sensors (distance in meters)	MPD IC1, IV1 & IF1 Sensors (distance in meters)
24	0.25	12 (47 ft.)	30 (97 ft.)
22		20 (65 ft.)	50 (162 ft.)
20	0.5	30 (97 ft.)	80 (260 ft.)
18		50 (162 ft.)	120 (390 ft.)*
16	1.0	80 (260 ft.)*	200 (650 ft.)*

\* Frequency of zero calibration may increase due to the changes in wire resistance at different temperatures.

## 2.4 Cable Connections

The sensor is connected by three wires:

Connections		Color Code
Sensitive	(S)	Brown
Non-sensitive	(NS)	Blue
Common	(01)	White

A 3-way terminal block is provided in the terminal enclosure to enable connection to be made to the control unit. Earthing facilities are available if required.

### NOTE

The black and red wires from the MPD are not used with the XNX mV Personality Board. Insure they are properly isolated from live connections. DO NOT CUT.

---

## 2.5 Fitting Sensors



### **WARNING**

Before installing the sensors, isolate the power supply by disconnecting or removing the associated control module from the installation.



### **CAUTION**

- The sensitivity of catalytic sensors is impaired by silicone compounds. Do not expose the sensors to silicones or silicone-based products.
- The sintered disc on the sensor assembly must be kept free from containments; i.e. oil and dirt.
- The relevant site procedures must be obeyed at all times when opening the Terminal Housing or removing the sensor in a hazardous areas.

If replacing a sensor refer to CAUTION 1 in Section 4 - Maintenance.

To fit the MPD proceed as follows:

1. Remove the protection disc and fit the accessories as required. (Refer to Section 3 - Fitting Accessories).
2. Isolate the power supply and wait for five minutes.
3. Remove the Terminal Housing lid.
4. Pass the cable into the Terminal Housing and fit the sensor to housing. To comply with the certification requirements, a minimum of five threads must be engaged.
5. Connect the sensor cable to the terminal block. (See the label adjacent to the connector).
6. After mounting the Terminal Housing in the required location, connect the associated Control Module wiring to the terminal block (see the label).
7. Replace and secure Terminal Housing lid.
8. If not already replaced by accessories, unscrew the Filter Housing, remove the protection disc and replace Filter Housing and gasket.

### **NOTE**

The Hydrophobic Barrier is retained in position by the Filter Housing, or one of the accessories.

9. Connect power supply to the Sensor by reconnecting or replacing the associated Control Module.
10. Calibrate the system as detailed in the equipment manual.

### **NOTE:**

Calibration of the MPD is mandatory before the detector can be used for gas monitoring. Refer to Section 7 - Calibration for the proper procedure.

---

## 3. Fitting Accessories

### 3.1 Collecting Cone

(02000-A-1462)



To fit the Collecting Cone to a sensor, carry out the following:

1. Remove the Filter Housing and gasket from the sensor.
2. Fit the Stainless Steel Filter.
3. Screw the Collecting Cone onto the sensor accessory thread and tighten firmly by hand.

See Appendix A in the XNX Technical Manual for more Local HART Handheld information.

### 3.2 Weatherproof Housing

(SPXCDWP)



For FM 6340 performance approvals on MPD-BT-IC1 and MPD-UT-IC1, SPXCDWP must be installed for IP66 compliance.

Note: Environmental conditions that compromise the IP66 protection provided by the weather proof cover will extend published response times. Safety protocols or maintenance procedures that consider these environmental conditions are recommended specific to the installation.

### 3.3 Weatherproof Cap

(02000A1640)



To fit a Weatherproof Cap to a sensor carry out the following:

1. Remove the Filter Housing and gasket from the sensor.
2. Fit the Stainless Steel Filter.
3. Screw the Weatherproof Cap on to sensor accessory thread and tighten firmly by hand.

### 3.4 Sample/Calibration Gas Flow Adaptor

(1226A0411)

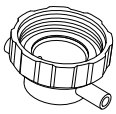

To fit a Flow Adaptor to the sensor, carry out the following:

1. Remove the Filter Housing and gasket from the sensor.
2. Ensure that the Flow Adaptor is fitted with its gasket.
3. Apply a thin coating of anti-seize compound, such as light petroleum grease, to the sensor accessory thread.
4. If required fit the Stainless Steel Filter, screw the Flow Adaptor on to the sensor and tighten with a 47mm A/F spanner.
5. Set the sample flow rate to  $0.5 \pm 0.2$  liters per minute, unless otherwise directed in System installation instructions.

See Appendix B in the XNX Technical Manual for more Modbus information.

### 3.5 Duct Mount Kit



The Duct Mounting Kit (S3KDMK), when combined with the MPD Interface Adaptor (1226A0382), the Duct Mounting Kit can accommodate the MPD to detect flammable gases in a duct application. The kit includes the adaptor, gasket and required fasteners. The MPD Interface Adaptor includes only the adaptor and requires the S3KDMK Duct Mounting Kit.

---

## 4. Maintenance

### 4.1 General

Maintenance consists of cleaning the sensor and accessories, replacing gasket and the Hydrophobic Barrier and gassing the sensor when testing the system.



#### **CAUTIONS**

- **The sensitivity of Catalytic Sensors is impaired by silicone compounds. Do not expose to silicones or silicone based products.**
- **Dismantling of a sensor or a sensor installation by other than authorized engineers invalidates certification.**

In the event of exposure to contaminant or prolonged exposure to high concentration of gas, the sensor should be operated for 24 hours in a clean environment and then recalibrated.

#### **NOTE**

If the sensor is found to be faulty, or cannot be calibrated, the sensor cartridge is replaceable.

Dispose of in accordance with local disposal regulations. For more information on sensor disposal, contact your HA Representative.

### 4.2 Cleaning

Sensor and accessories may be cleaned using an industrial grade of methanol, providing the appropriate safety precautions are taken when handling this solvent.

### 4.3 Sensor Cell Replacement

Using Figure 8 as a guide, follow the procedure below:

1. Check that the label on the new sensor cell is the correct gas type.
2. Remove power from the transmitter.
3. Unscrew the weatherproof cover (if equipped), loosen the retainer locking screw and unscrew the sensor retainer.
4. Remove the old sensor cell by pulling without twisting.
5. Replacement cartridges are designed to seal against an O-ring in the sensor retainer. Verify O-ring described is in place prior to reassembly.
6. Slide the replacement cell into the MPD body taking care to align the tab with the alignment slot, then press the cell firmly to seat it into the body.
7. Refit the sensor retainer, tighten until hex is flush with the body of the sensor.
8. Tighten the locking screw and refit the weatherproof cover (if equipped).
9. Recalibrate the detector following the procedures in Section 7.

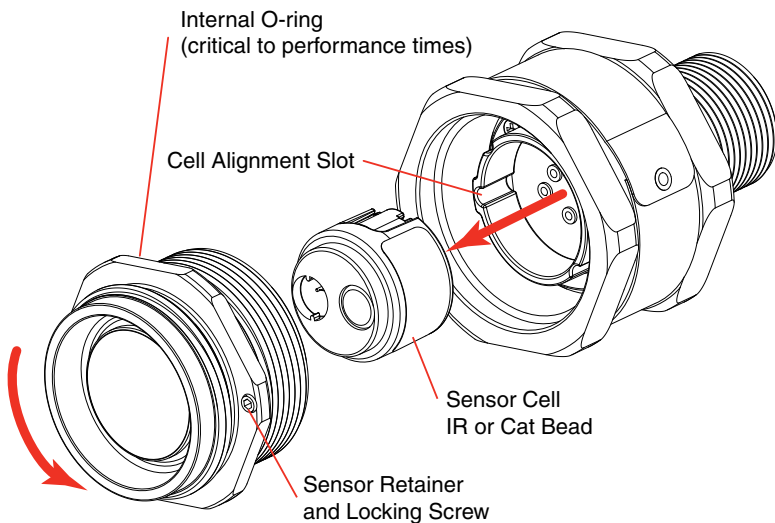

Figure 9. Replacing Plug In Sensor

## 5. Faults

The following table provides a list of possible faults related to the sensor together with possible causes and remedies.

Fault	Cause/Remedy
Sensor reads non-zero all the time	Gas could be present, ensure there is no combustible gas in the atmosphere.
Sensor reads non zero when no gas is present	Adjust the zero of the control system.
Sensor reads low when gas is applied	Adjust the span of the control system.
Sensor reads high when gas is applied	Adjust the span of the control system.
Sensor reads zero when gas is applied	<ul style="list-style-type: none"> <li>• check the wiring.</li> <li>• check that the dust protection cap has been removed.</li> <li>• check that the sinter is not obstructed.</li> <li>• replace the sensor if poisoning is suspected.</li> </ul>

In the event of exposure to contaminant, e.g. silicones or silicone based products, or prolonged exposure to high concentration of gas, the sensor should be operated for 24 hours in a clean environment and then recalibrated.

If the sensor is found to be faulty, or cannot be calibrated, the complete sensor must be discarded and replaced.

---

## 6. Functional Gas Test (Bump Test)

### 6.1 Sensor without Accessories

Where there are no accessories fitted, it is recommended that a Flow Adaptor is used when gassing the sensor. Where this is not possible, a suitable plastic bag may be used.

### 6.2 Sensor with Collecting Cone or Weatherproof Cap

1. Using the rubber tubing, connect the test gas to the gassing nozzle or to the permanently connected tubing if fitted.



#### **CAUTION**

- **Upward pressure on the gassing nozzle of the Weatherproof Cap forces the nozzle against the sinter. Rotation of the nozzle may damage the sinter if a filter is not fitted.**
  - **Direct gassing of the sensor via the nozzle on the Collecting Cone in wind speeds of greater than 5 meters per second may cause errors.**
2. Set the flow rate to  $1.5 \pm 0.1$  liters per minute and test the system in accordance with the instructions in the appropriate system equipment manual.
  3. On completion, shut off the test gas and disconnect the rubber tubing.

### 6.3 Sensor with Sample/Calibration Gas Flow Adaptor

1. Shut off the sample flow to the Flow Adaptor.
2. Disconnect the input pipeline from the input nozzle of the Flow Adaptor.
3. Using the rubber tubing, connect the test gas to the Flow Adaptor input nozzle.
4. Set the flow rate to  $0.5 \pm 0.2$  liters per minute and test the system in accordance with the instructions in the appropriate system equipment manual.
5. On completion, shut off the test gas and disconnect the rubber tubing.
6. Reconnect the input pipeline to the Flow Adaptor input nozzle and restore the sample flow.

---

## 7. Calibration



### CAUTION

The calibration procedure should only be performed by qualified personnel.

#### NOTE:

Honeywell Analytics recommends that the maximum calibration interval be 6 months or in accordance with customer site procedures, whichever is sooner to assure the highest level of safety. Correct operation of each sensor/detector should be confirmed with test gas of known concentration before each use.

### 7.1 Zero and Span Calibration for MPD Sensors with XNX Universal Transmitter



### CAUTION

Before initial calibration allow the detector to stabilize for 30 minutes after applying power. When in zero and span calibration mode the current output from the detector is inhibited (e.g. default 2mA) to avoid false alarms.

Extended or frequent exposure to elevated concentrations of combustible gases may affect sensor sensitivity. Verify sensor performance by frequent calibration.

This section describes how to calibrate MPD sensors fitted to the XNX Universal Transmitter.

The calibration adjustments are made on the XNX's display and gassing is performed at the sensor (this may be locally or remotely located).

The following equipment is required:

- Sample/Calibration Gas Flow Adaptor (Part No: 1226A0411)
- Test gas
- Regulator

#### NOTE

Zero gas and Span gas should be at roughly the same humidity levels to avoid erroneous cell responses.

1. At the MPD, remove the Weatherproof Cap if equipped.
2. Fit the Flow Adaptor onto the MPD.

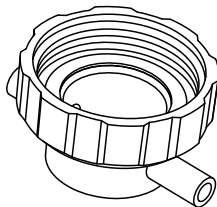

Figure 10. Flow Adaptor

Reverse the cap removal procedure. The following diagram shows the Flow Adaptor accessory fitted to the MPD.

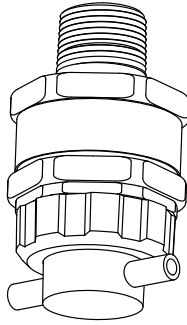

Figure 11. MPD with Flow Adaptor

### **NOTE**

The Gas Calibration menu is for both Zero and Span Calibration.

3. Connect the Flow Adaptor (using either gas pipe) to the regulated cylinder containing a known concentration of the target gas at approximately the sensor alarm point (e.g. 50% LEL Methane in air).



### **WARNING**

**As some test gases may be hazardous, the Flow Adaptor outlet should exhaust into a safe area.**

4. Follow the procedure in Section 3.2.1 of XNX Universal Transmitter Technical Manual for both Zero and Span calibrations.
5. Apply the target gas to the sensor. Pass the gas through the Flow Adaptor at a rate of  $0.5\text{l/m} \pm 0.2\text{l/m}$ .

### **NOTE:**

Sensors should be calibrated at concentrations representative of those to be measured. It is always recommended that the sensor is calibrated with the target gas it is to detect.



### **CAUTION**

**Where the user calibrates any sensor using a different gas, responsibility for identifying and recording calibration rests with the user. Refer to the local regulations where appropriate.**

6. Ensure that the sensor and the vicinity around it are clear all traces of the calibration gas before continuing. This is to avoid triggering spurious alarms. If calibration fails at any point discard the cartridge and replace with a new one.
7. Remove the test equipment, refit the weatherproof cap to the sensor (if previously removed for the test) and return the system to normal operation.

## 7.2 Cross Calibration procedure for MPD-CB1



### CAUTION

Where the user calibrates any sensor using a different gas, responsibility for identifying and recording calibration rests with the user. Refer to local regulations where appropriate.

When the MPD-CB1 Combustible LEL sensor is to be calibrated with a gas which is different to the gas or vapor to be detected, the following cross calibration procedure should be followed:

### NOTE

- Table 1 lists the gases according to the reaction they produce at a given detector.
- An eight star (8\*) gas produces the highest output, while a one star (1\*) gas produces the lowest output. (These are not applicable at ppm levels.)

Gas	Star Rating	Gas	Star Rating
Acetone	4*	Hexane	3*
Ammonia	7*	Hydrogen	6*
Benzene	3*	Methane	6*
Butanone	3*	Methanol	5*
Butane	4*	Nonane	2*
Butyl acetate	1*	MIBK	3*
Butyl acrylate	1*	Octane	3*
Cyclohexane	3*	Pentane	4*
Cyclohexanone	1*	Propane	5*
Diethyl ether	4*	Propan-2-ol	4*
Ethane	6*	Styrene	2*
Ethanol	5*	Tetra hydrofuran	4*
Ethyl acetate	3*	Toluene	3*
Ethylene	5*	Triethylamine	3*
Heptane	3*	Xylene	2*

Table 1. Star Rating of Gases

To cross calibrate the MPD-CB1 combustible gas sensor:

1. Obtain the star rating for both the test gas and the gas to be detected from Table 1.
2. Set the gas selection to the star rating which is the same star rating of the gas being detected.
3. These values may then be used in Table 2 to obtain the required meter setting when a 50% LEL test gas is applied to the detector.

### NOTE

These settings must only be used with a calibration gas concentration of 50% LEL.

* Rating of Calibration Gas	* Rating of Gas to be Detected							
	8*	7*	6*	5*	4*	3*	2*	1*
8*	50	62	76	95	-		-	-
7*	40	50	61	76	95	-		-
6*	33	41	50	62	78	95	-	
5*	26	33	40	50	63	79	95	-
4*	-	26	32	40	50	63	80	95
3*	-	-	26	32	40	50	64	81
2*	-	-	-	25	31	39	50	64
1*	-	-	-	-	25	31	39	50

Table 2. Meter Settings

- If a sensor is to be used to detect a gas other than that for which it was calibrated, the required correction factor may be obtained from Table 3. The meter reading should be multiplied by this number in order to obtain the true gas concentration.

Sensor calibrated to detect	Sensor Used To Detect							
	8*	7*	6*	5*	4*	3*	2*	1*
8*	1.00	1.24	1.52	1.89	2.37	2.98	3.78	4.83
7*	0.81	1.00	1.23	1.53	1.92	2.40	3.05	3.90
6*	0.66	0.81	1.00	1.24	1.56	1.96	2.49	3.17
5*	0.53	0.66	0.80	1.00	1.25	1.58	2.00	2.55
4*	0.42	0.52	0.64	0.80	1.00	1.26	1.60	2.03
3*	0.34	0.42	0.51	0.64	0.80	1.00	1.27	1.62
2*	0.26	0.33	0.40	0.50	0.63	0.79	1.00	1.28
1*	0.21	0.26	0.32	0.39	0.49	0.62	0.78	1.00

Table 3. Meter Multiplication Factors

## NOTE

Since combustible sensors require oxygen for correct operation, a mixture of gas in air should be used for calibration purposes. Assuming average performance of the sensor, the sensitivity information in Tables 1 to 3 is normally accurate to +20%.

## EXAMPLE

If target gas to be detected is **Butane** and the calibration gas available is **Methane** (50% LEL):

- Look up the star rating for each gas in Table 1: **Butane 4\*** and **Methane 6\***.
- Check the meter settings for 50% LEL calibration gas in Table 2; in this case, **78**.
- The meter should therefore be set to 78% to give an accurate reading for Butane using 50% LEL Methane as a calibration gas.

## NOTE

It is important to calibrate the sensor at the approximate alarm levels to allow for non-linearity of the sensors at gas concentrations above 80% LEL.

### 7.3 MPD-CB1 Flammable Sensor Operational Life

The pellistors used in the flammable gas sensor can suffer from a loss of sensitivity when in the presence of poisons or inhibitors, e.g. silicones, sulfides, chlorine, lead or halogenated hydrocarbons. The pellistors are poison resistant to maximize the operational life of the flammable sensor. A typical operating life, subject to the presence of poisons/inhibitors is 36 months.

### 7.4 Meter Multiplication Factors for MPD-IF1

It is possible to apply a linear cross reference factor to the output of a sensor characterized for propane and achieve the results shown in the graph below. Reasonable accuracy is maintained to at least the 50% LEL equivalent values of the cross-referenced gases.

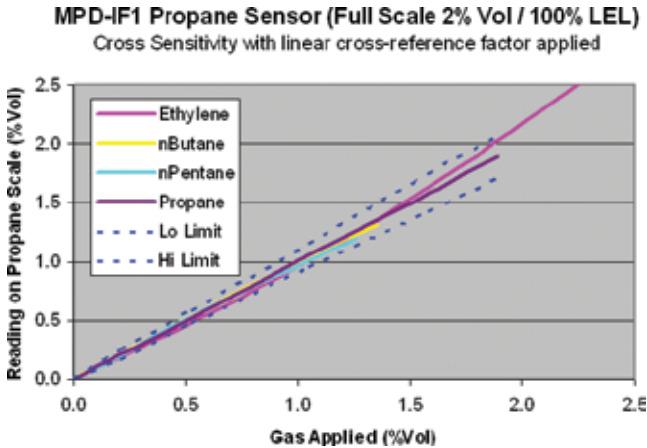

Figure 12. MPD-IF1 (Propane) Sensor with linear cross-reference factor applied

Use the following multiplying factors to cross-refer to the propane reading:

Gas	Multiplication Factor
Ethylene	5.43
nButane	0.98
nPentane	0.93

Table 4. Multiplying Factors



#### CAUTION

- These factors only apply to gas concentrations expressed in % Volume terms.
- When using a linear cross reference factor the temperature compensation is based upon propane, and there may be errors at temperatures away from the calibration temperature.

#### NOTE

Honeywell Analytics recommends that users verify the accuracy of their instruments using test gases wherever possible. Cross-referred measurements should be used as a guide only, not as absolute values.

## 8. Replacement Parts

### 8.1 MPD Catalytic Bead and IR Replacement Sensor Cartridges

Sensor Type	Target Gas	Cartridge Part No	Maximum Range	Selectable Range	Increment	Default Range
MPD-IC1	Carbon Dioxide	1226-0301	5.00 %Vol	1.00 to 5.00 %Vol	1.00 %Vol	5.00 %Vol
MPD-IV1	Methane	1226-0299	5.00 %Vol or 0-100%LEL	1.00 to 5.00 %Vol or 0-100%LEL	n/a	0-100%LEL
MPD-IF1	Flammables	1226-0300	100 %LEL	20 to 100 %LEL	10 %LEL	100 %LEL
MPD-CB1	Flammables	1226A0359	100 %LEL	20 to 100 %LEL	10 %LEL	100 %LEL

**NOTE:**

When ordering replacement MPD sensor cartridges, the replacement cartridge **MUST** be the same type as factory configured. Substituting a different cartridge will void agency certification.

### 8.2 Terminal Housings

**NOTE**

When ordering replacements, always quote the complete part number. Where a part number is not listed or known, state type, material, cable entry size and other relevant details.

Part Number	Description	Cable Entry Thread
2441-0022	UL/CSA Aluminum Junction Box (2 entries)	3/4 NPT
2110B2103	UL/CSA Stainless Steel Junction Box (2 entries)	3/4 NPT
00780-A0100	ATEX/IEC Junction Box (3) M20, (1) M25 entries.	M20/M25

### 8.3 Maintenance Spares

When ordering replacements, always quote the complete part number.

Part Number	Description
1226A0354	Remote Gassing Port
02000-A-1642	Collecting Cone
1226A0411	Sample Flow Adaptor
02000A1640	Weatherproof Cap
S3KDMK	Duct Adaptor Kit
1226A0382	MPD Duct Interface Adaptor (S3KDMK req'd)
SPXCDWP	Weatherproof Housing

## 8.4 MPD Calibration Gases

Sensor Type	Target Gas	Cal Gas Range	Cal Gas P/N	Cal Gas Description
MPD-IC1	Carbon Dioxide	1.50 to 3.5 %Vol	Contact HA	2.5 %VOL CO <sub>2</sub> in air
MPD-IV1	Methane	1.50 to 3.5 %Vol	GFV352	2.5 %VOL CH <sub>4</sub> in air or LEL
MPD-IF1	Flammables	30 to 70 %LEL	GFV406	1 %VOL C <sub>3</sub> H <sub>8</sub> in air
MPD-CB1	Flammables	30 to 70 %LEL	GFV352	50 %LEL CH <sub>4</sub> in air

## 9. Specifications

### 9.1. General Specifications

Electrical		
Sensor	Operating Voltage	Power Consumption
MPD**-CB1	2.9	0.2
MPDXX-I**	4	0.08
	Negative going signal with concentration	
Connection	5-20 AWG (0.52 mm <sup>2</sup> ) by 7: (178 mm) long	
Construction		
Dimensions	2.2" (56 mm) D x 3" (76 mm) L	
Weight	1.2 lbs. (0.54 kg)	
Material	316 stainless steel	
Port Types	MPD-UT*** (factory sealed): 3/4" male N.P.T.	
	MPD-BT*** (factory sealed): 3/4" male N.P.T.	
	MPD-AM***: M25 male	
Environmental - Operating		
IP Rating	IP66	
Temperature	MPD**-CB1: -40°C to +65°C (-40°F to +149°F)	
	MPD**-I**: -20°C to +50°C (-4°F to +122°F)	
Humidity	see sections 9.3 - 9.6	
Environmental - Storage		
Temperature	-40°C to +65°C / -40°F to +149°F	
Humidity	0 to 99% RH non-condensing	

### 9.2 Performance Data

Sensor Type	Gas	Response Time (T50) sec	Response Time (T90) sec	Accuracy (% of full scale or % of applied gas)
MPD-IC1	Carbon Dioxide	<30	<70	±5%FS or ±15%
MPD-IV1	Methane	<15	<30	±5%FS or ±15%
MPD-IF1	Propane	<15	<30	±5%FS or ±15%
MPD-CB1	Methane	<15	<30	±5%FS or ±15%

Sensor Type	Drift Over Time	Operating Temperature		Operating Pressure	Operating Air Speed
		Min	Max		
MPD-IC1	< 3%/yr	-20°C / -4°F	+50°C / 122°F	80kPa ~ 110kPa	0 ~ 6m/sec
MPD-IV1	< 3%/yr	-20°C / -4°F	+50°C / 122°F	80kPa ~ 110kPa	0 ~ 6m/sec
MPD-IF1	< 3%/yr	-20°C / -4°F	+50°C / 122°F	80kPa ~ 110kPa	0 ~ 6m/sec
MPD-CB1	< 3%/yr	-40°C / -40°F	+65°C / 149°F	80kPa ~ 120kPa	0 ~ 6m/sec

## NOTES

- Data taken at 20-25°C. Contact HA for any additional data or details.
- Response times may increase at lower temperatures.
- Data represents typical values *without optional accessories attached* (MPD\*\*IC1 with SPXCDWP. T5<60, T90<120).
- Note: Environmental conditions that compromise the IP66 protection provided by the weather proof cover will extend published response times. Safety protocols or maintenance procedures that consider these environmental conditions are recommended specific to the installation.
- System conditioning may be required to achieve stated results. Contact HA for details.
- Performance figures are measured using a sample humidity of 50% RH.
- Performance figures are measured between 40 and 60% of full scale.
- Performance figures are measured by test units calibrated at 50% of full scale.

### 9.3 MPD-CB1

Characteristic	Description
<b>Gases Detected:</b>	Methane gas in the %LEL range. Combustible gases in the %LEL range with sensitivity dependent on gas type.
<b>Measuring Range:</b>	0 – 100%LEL Methane Other gas ranges may vary.
<b>Environmental - XNX MPD Sensor Storage Temperature</b>	-40°C to +65°C/-40°F to +149°F
<b>Operating Temperature Range:</b>	-40°C to +65°C
<b>Operating Humidity Range:</b>	Continuous: 20 to 90% RH non-condensing Intermittent: 10 to 99% RH non-condensing
<b>Operating Pressure Range:</b>	80 to 120 kPa
<b>Warm Up Time:</b>	10 minutes
<b>Response Time:</b>	<30 seconds Time to reach 90% of a step change in gas concentration of 100% of FS Methane measured in accordance with the Canadian Standards Association (CSA) method of testing.
<b>Voltage Range:</b>	2.42V to 2.90V Bridge (at 200mA drive current)
<b>Drive Current:</b>	200mA ± 1mA (From control equipment)
<b>Power Consumption:</b>	<600mW
<b>Signal Output:</b>	mV Bridge
<b>Linearity:</b>	<±5% FS
<b>Accuracy:</b>	<±5% FS
<b>Zero Stability with Time:</b>	<±3% FS/year
<b>Span Stability with Time:</b>	<±5% FS/year
<b>Poisoning:</b>	The sensing elements may become inactive after extensive exposure to silicones, halogenated hydrocarbons, and heavy metal or sulfur compounds.
<b>Expected Operating Life:</b>	5 years (Typical without Poisoning)
<b>Dimensions:</b>	2.080 in Dia x 3.016 in L / 52.83 mm Dia x 76.62 mm L
<b>Weight:</b>	1.2 lbs / 544.3g

#### 9.2.1 MPD-CB1 Cross Sensitivity

Cross sensitivity information for MPD-CB1 can be found in Section 7.2, Tables 1 and 3.

## 9.4 MPD-IV1

Characteristic	Description
<b>Gases Detected:</b>	Methane gas in the %Vol and %LEL range.
<b>Measuring Range:</b>	0 – 5.00%Vol 0 – 100%LEL
<b>Operating Temperature Range:</b>	-20°C to +50°C
<b>Operating Humidity Range:</b>	0 to 95% RH non-condensing
<b>Operating Pressure Range:</b>	80 to 110 kPa
<b>Warm Up Time:</b>	3 minutes
<b>Response Time:</b>	T90 = <30 seconds Time to reach 90% of a step change in gas concentration of 100% of FS Methane
<b>Voltage Range:</b>	3.0V ~ 5.0V (From control equipment)
<b>Drive Current:</b>	75mA ~ 85mA (From control equipment)
<b>Power Consumption:</b>	<500mW
<b>Signal Output:</b>	mV Bridge
<b>Linearity:</b>	<±5% FS
<b>Accuracy:</b>	<±5% FS
<b>Zero Stability with Time:</b>	<±3% FS/year
<b>Span Stability with Time:</b>	<±5% FS/year
<b>Span Stability with Temperature:</b>	<±10% of reading up to 50% FSD, ±15% of reading from 50% to 100% FSD or 2% FSD whichever is greater over the operating temperature range.
<b>Expected Operating Life:</b>	5 years
<b>Dimensions:</b>	2.080 in Dia x 3.016 in L / 52.83 mm Dia x 76.62 mm L
<b>Weight:</b>	1.2 lbs / 544.3g

## 9.5 MPD-IF1

Characteristic	Description
<b>Gases Detected:</b>	Propane gas in the %LEL range. Combustible gases in the %LEL range with sensitivity dependent on gas type.
<b>Measuring Range:</b>	0 – 100%LEL Propane Other gas ranges may vary.
<b>Operating Temperature Range:</b>	-20°C to +50°C
<b>Operating Humidity Range:</b>	0 to 95% RH non-condensing
<b>Operating Pressure Range:</b>	80 to 110 kPa
<b>Warm Up Time:</b>	3 minutes
<b>Response Time:</b>	T90 = <30 seconds Time to reach 90% of a step change in gas concentration of 100% of FS Propane
<b>Voltage Range:</b>	3.0V ~ 5.0V (From control equipment)
<b>Drive Current:</b>	75mA ~ 85mA (From control equipment)
<b>Power Consumption:</b>	<500mW
<b>Signal Output:</b>	mV Bridge
<b>Linearity:</b>	<±5% FS
<b>Accuracy:</b>	<±5% FS
<b>Zero Stability with Time:</b>	<±3% FS/year
<b>Span Stability with Time:</b>	<±5% FS/year
<b>Span Stability with Temperature:</b>	<±10% of reading up to 50% FSD, ±15% of reading from 50% to 100% FSD or 2% FSD whichever is greater over the operating temperature range.
<small>* May not be applicable when using gas cross-reference factors</small>	
<b>Expected Operating Life:</b>	5 years
<b>Dimensions:</b>	2.080 in Dia x 3.016 in L / 52.83 mm Dia x 76.62 mm L
<b>Weight:</b>	1.2 lbs / 544.3g

## 9.6 MPD-IC1

Characteristic	Description
<b>Gases Detected:</b>	Carbon Dioxide in the %Vol range.
<b>Measuring Range:</b>	0 – 5.00%Vol
<b>Operating Temperature Range:</b>	-20°C to +50°C
<b>Operating Humidity Range:</b>	5 to 95% RH non-condensing
<b>Operating Pressure Range:</b>	80 to 110 kPa
<b>Warm Up Time:</b>	3 minutes
<b>Response Time:</b>	T50 = <30 seconds, T90 = <70 seconds with SPXCDWP, T50 = <60 seconds, T90 = <120 seconds Time to reach 50% and 90% of a step change in gas concentration of 100% of FS Carbon Dioxide
<b>Voltage Range:</b>	3.0V ~ 5.0V (From control equipment)
<b>Drive Current:</b>	75mA ~ 85mA (From control equipment)
<b>Power Consumption:</b>	<500mW
<b>Signal Output:</b>	mV Bridge
<b>Linearity:</b>	<±5% FS
<b>Accuracy:</b>	<±15% of reading
<b>Zero Stability with Time:</b>	<±3% FS/year
<b>Span Stability with Time:</b>	<±5% FS/year
<b>Span Stability with Temperature:</b> <small>* May not be applicable when using gas cross-reference factors</small>	<±10% of reading up to 50% FSD, ±15% of reading from 50% to 100% FSD or 2% FSD whichever is greater over the operating temperature range.
<b>Expected Operating Life:</b>	5 years
<b>Dimensions:</b>	2.080 in Dia x 3.016 in L / 52.83 mm Dia x 76.62 mm L
<b>Weight:</b>	1.2 lbs / 544.3g

## 9.7 MPD Certifications by Part Number Series

UL/CSA Certifications by Part Number Series									
		MPD-UTCB1 (Cat Bead)	MPD-UTIV1 (IR Methane)	MPD-UTIF1 (IR Flam)	MPD-UTIC1 (IR CO <sub>2</sub> )	MPD-BTCB1	MPD-BTIF1	MPD-BTIV1	MPD-BTIC1
C-UL	<b>Hazardous Location - UL</b>								
	UL 1203	T	T	T	T	T	T	T	T
CSA	<b>Hazardous Location - CSA</b>								
	CAN/CSA C22.2 No. 30 M-1986	T	N/A	N/A	T	N/A	N/A	N/A	N/A
	<b>Performance with XNX Transmitter XNXUT*V-*****</b>								
	CSA C22.2 No. 152	T	N/A	N/A	N/A	N/A	N/A	N/A	N/A
FM Listed	<b>Performance with XNX Transmitter XNXUT*V-*****, XNXBT*V-*****</b>								
	FM 6310 / 6320	T	N/A	N/A	N/A	T	N/A	N/A	N/A
	FM 6430	N/A	N/A	N/A	T	N/A	N/A	N/A	T

ATEX/IEC Certifications by Part Number Series					
		MPD-AMCB1 (Cat Bead)	MPD-AMIV1 (IR Methane)	MPD-AMIF1 (IR Flam)	MPD-AMIC1 (IR CO <sub>2</sub> )
CE Mark EMC Compliance	<b>Electromagnetic &amp; Safety</b>				
	EU directive 2004/108/EC	B	B	B	B
	EN 50270:2006	B	B	B	B
	EU directive 94/9/EC	M	M	M	M
ATEX/ DEMKO	<b>Hazardous Location</b>				
	CENELEC EN 60079-0:2012	M	M	M	M
	CENELEC EN 60079-1:2007	M	M	M	M
	CENELEC EN 60079-29	M	M	M	M
	CENELEC EN 60079-31:2009	M	M	M	M
IECEX	IEC 60079-0, 6th Ed	M	M	M	M
	IEC 60079-1 6th Ed	M	M	M	M
	IEC 60079-31	M	M	M	M

Legend: M = M25 threaded Adaptors, T = 3/4 NPT threaded Adaptors, B = Both 3/4 NPT and M25, N/A = Not Approved or Not Applicable

## 9.7.1 MPD Hazardous Area Approvals

Description		MPD-UTCB1	MPD-UT1F1	MPD-UTIV1	MPD-UTIC1	MPD-BTCB1	MPD-BT1F1	MPD-BTIV1	MPD-BTIC1	MPD-AMCB1	MPD-AM1F1	MPD-AMIV1	MPD-AMIC1
CSA	Class I, Division 1 Groups B,C,D	●			●								
UL	Class I Division 1 Groups B,C, D	●	●	●	●	●	●	●	●				
	Class II Division 1 Groups F & G	●	●	●	●	●	●	●	●				
FM Approvals	AEx d IIB+ H2 T4 -40 °C ≤ Tamb ≤ 65°C	●				●							
	AEx d IIB+ H2 T4 -20 °C ≤ Tamb ≤ 50°C				●				●				
INMETRO	Ex D IIB + H2 IP66 -40°C ≤ Ta ≤ 65°C									●			
	Ex D IIB + H2 IP66 -20 °C ≤ Ta ≤ 50°C I										●	●	●
UL/Demko	II 2 G Ex d IIB +H2 Gb (Tamb -40 °C to 65 °C) IP66									●			
	II 2 G Ex d IIB +H2 Gb (Tamb -20 °C to 50 °C) IP66										●	●	●
	II 2 D Ex tb IIIC Db IP 66									●	●	●	●

## 9.7.2 MPD Certification Labels

Refer to the table below for label details.

### UL/CSA/FM Certification Label for MPD-UTCB1

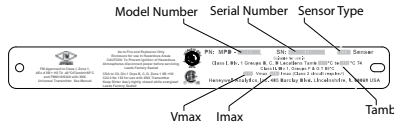

### UL Certification for MPD-UT1\*\*

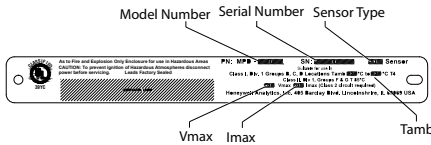

### UL/INMETRO Label for MPD-BTIF1 and MPD-BTIV1

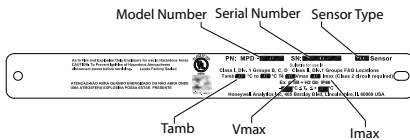

### UL/INMETRO/FM Label for MPD-BTIC1 and MPD-BTCB1



### ATEX Certification Label for MPD-AM-\*\*\*\*

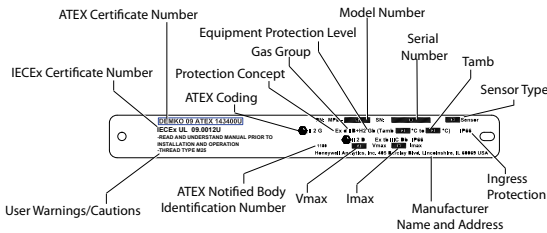

Serial Number		Serial Number	Vmax	I <sub>max</sub>	Sensor Type	Tamb
MPD-UT MPD-BT MPD-AM	CB1	WWYYNNNN	2.9	0.2	%LEL	-40°C to +65°C (-40°F to +149°F)
	IF1	WW = week	4	0.08	%LEL	-20°C to +50°C (-4°F to +122°F)
	IV1	YY = year	4	0.08	CH4	-20°C to +50°C (-4°F to +122°F)
	IC1	NNNN = Seq. #	4	0.08	CO2	-20°C to +50°C (-4°F to +122°F)

---

## 10. Warranty

### Warranty Statement

All products are designed and manufactured to the latest internationally recognized standards by Honeywell Analytics under a Quality Management System that is certified to ISO 9001.

The Multi-Purpose Detector (MPD) is warranted by Honeywell Analytics (herein referred to as 'HA') to be free from defects in material or workmanship under normal use and service for:

Device	Warranty Terms
Multi-Purpose Detector (MPD)	<b>12 months</b> from date of commissioning by an approved Honeywell Analytics representative or <b>18 months</b> from date of shipment from Honeywell Analytics Whichever is sooner

**Service in the field or at the customer's premises is not covered under these warranty terms. Time and travel expenses for on-site warranty services will be charged at Honeywell Analytics' normal billing rates. Contact your Honeywell Analytics Service Representative for information on Service Contracts.**

### Warranty Conditions

1. The Honeywell Analytics (HA) Limited Product Warranty only extends to the sale of new and unused products to the original buyer where purchased from HA or from a HA authorized distributor, dealer or representative. Not covered are: consumable items such as dry-cell batteries, filters and fuses or routine replacement parts due to the normal wear and tear of the product; any product which in HA's opinion has been altered, neglected, misused or damaged by accident or abnormal conditions of operation, handling, use or severe sensor poisoning; defects attributable to improper installation, repair by an unauthorized person or the use of unauthorized accessories/parts on the product.
2. Any claim under the HA Product Warranty must be made within the warranty period and as soon as reasonably possible after a defect is discovered. If a Warranty claim is being sought it is the responsibility of the buyer to obtain a Service Event number (SE#) from HA and if practical return the product clearly marked with the SE# and a full description of the fault.
3. HA, at its sole discretion, may elect to send replacement goods to buyer prior to receipt of the defective goods. Buyer agrees to return defective goods within 30 days or to pay for the replacement goods.
4. Buyer is responsible for transportation costs from the buyer's location to HA. HA is responsible for transportation costs from HA's location to the buyer.

- 
5. If in the case of a fixed installation or when it is not practical to return the product, the buyer should submit a claim to HA Service Department. A service engineer will attend on site on a day rate basis. Where a valid warranty claim is identified, the faulty product will be repaired or replaced free of charge. A warranty claim will be accepted if all conditions contained within this Warranty are met.
  6. When, in the opinion of HA, a warranty claim is valid, HA will repair or replace the defective product free of charge and send it or any replacement back to the buyer. If, in the opinion of HA the warranty claim is not valid, HA will, at the option of the buyer, return the unit unaltered at the buyer's expense, repair the unit at the then prevailing rates, replace the unit with an appropriate replacement item at the then prevailing price, or discard the unit. HA reserves the right to charge for any attendance by its service engineer at the usual rates in force at the time the claim was received.
  7. In no event shall HA's liability exceed the original purchase price paid by the buyer for the product.

### **Consumer Claims**

If you purchased your HA product as a consumer, the above warranty conditions do not affect your rights under any applicable consumer protection legislation.

Honeywell Analytics reserves the right to change this policy at any time. Contact Honeywell Analytics for the most current warranty information.

# 11. EC Declaration of Conformity

Honeywell



## EC Declaration of Conformity

The undersigned of

**Honeywell Analytics Inc**  
405 Barclay Boulevard  
Lincolnshire, Illinois 60069

United States

Declares that the products listed below

For and on behalf of the importer

**Life Safety Distribution AG**  
Javastrasse 2  
8604 Hegnau  
Switzerland

## MPD Adaptor

The MPD (Multi Purpose Detector) is a serviceable flameproof and dust ignition protected housing, offered with either Catalytic Bead or Infrared sensors for the measurement of flammable and toxic gasses.

Are in conformity with the provisions of the following European Directive(s), when installed, operated, serviced and maintained in accordance with the installation/operating instructions contained in the product documentation:

**2004/108/EC**

**EMC Directive**

**94/9/EC**

**ATEX Directive – Equipment for use in Potentially Explosive Atmospheres**

And that the standards and/or technical specifications referenced below have been applied or considered:

Standard	Description	Product Part Numbers (*all versions)	Notified Body
EN 50270: 2006	Electromagnetic Compatibility – Electrical apparatus for the detection and measurement of combustible gases, toxic gases or oxygen	MPD*****	
EN 60079-0: 2012	Electrical apparatus for explosive gas atmospheres: General requirements	MPDAM***	UL-Demko
EN 60079-1: 2007	Electrical apparatus for explosive gas atmospheres: Flameproof enclosures "d"	MPDAM***	UL-Demko
EN 60079-31: 2009	Explosive atmospheres -- Part 31: Equipment dust ignition protection by enclosure "t"	MPDAM***	UL-Demko
EN 60529: 1991/ A1:2000	Degrees of protection provided by enclosures	MPD*****	UL-Demko

**Notified Body for Quality Assurance Notification:**

Baseefa Ltd  
Rockhead Business Park, Staden  
Buxton, Derbyshire, SK17 9RZ.  
Notified Body Number: 1180  
Quality Assurance Notification Number: Baseefa ATEX 5989

**Notified Body for ATEX Examination:**

UL International DEMKO A/S  
Lane Lyskaer 8, P.O. Box 514  
DK-2730 Herlev, Denmark  
Notified Body Number: 0539  
Certificate Number: 09ATEX0809943X  
Type Approval: II 2 GD, Ex d IIB+H2 Gb IP-66, Ex td IIIC Db

Year of CE marking: **2009**

Signature:

Name:

Position:

Date:

Declaration Number:

**Paul Silva**  
**Regulatory Compliance Manager**  
Date: **5<sup>th</sup> December 2012**  
MPD EC -004

Declaration of Conformity in accordance with EN ISO/IEC 17050-1:2010



## Find out more

[www.honeywellanalytics.com](http://www.honeywellanalytics.com)

## Contact Honeywell Analytics:

### Europe, Middle East, Africa, India

Life Safety Distribution AG  
Javastrasse 2  
8604 Hegnau  
Switzerland  
Tel: +41 (0)44 943 4300  
Fax: +41 (0)44 943 4398  
India Tel: +91 124 4752700  
[gasdetection@honeywell.com](mailto:gasdetection@honeywell.com)

### Americas

Honeywell Analytics Inc.  
405 Barclay Blvd.  
Lincolnshire, IL 60069  
USA  
Tel: +1 847 955 8200  
Toll free: +1 800 538 0363  
Fax: +1 847 955 8210  
[detectgas@honeywell.com](mailto:detectgas@honeywell.com)

### Asia Pacific

Honeywell Analytics Asia Pacific  
#508, Kolon Science Valley (I)  
187-10 Guro-Dong, Guro-Gu  
Seoul, 152-050  
Korea  
Tel: +82 (0)2 6909 0300  
Fax: +82 (0)2 2025 0329  
[analytics.ap@honeywell.com](mailto:analytics.ap@honeywell.com)

### Technical Services

EMEA: [HAexpert@honeywell.com](mailto:HAexpert@honeywell.com)  
US: [ha.us.service@honeywell.com](mailto:ha.us.service@honeywell.com)  
AP: [ha.ap.service@honeywell.com](mailto:ha.ap.service@honeywell.com)

[www.honeywell.com](http://www.honeywell.com)

# Honeywell

#### Please Note:

While every effort has been made to ensure accuracy in this publication, no responsibility can be accepted for errors or omissions. Data may change, as well as legislation, and you are strongly advised to obtain copies of the most recently issued regulations, standards and guidelines. This publication is not intended to form the basis of a contract.

1998-0745 Revision 8  
December 2012  
MAN0882\_EMEA1  
© 2012 Honeywell Analytics



**D**ETECTION | **S**AFETY | **P**ROTECTION

For Pricing or Further  
Information Please Contact Us.



**+441158390495**



**[www.manonglobal.com](http://www.manonglobal.com)**



**[sales@manonglobal.com](mailto:sales@manonglobal.com)**

---

**Leading UK Suppliers In  
Gas Detection, Safety & Protection  
Products  
Brand New & Genuine OEM Parts  
UK & Worldwide Deliveries Available**



Worldwide Delivery



1000+ Genuine Parts & Equipment