

# Training Presentation

XNX

**Honeywell**

# 'Premium' Gas Detection

- **Wide range of markets and applications including:**
  - Refineries and chemical plants, onshore oil and gas terminals, production platforms, exploration and drilling. Other 'socially aware/image conscious' industry leading companies.
- **Greater focus on performance, integration and long term ownership costs over initial cost.**
- **We add value by offering:**
  - Best solution to each application
  - Meeting / exceeding performance standards / requirements
  - Integrating as necessary to other systems
  - Reducing service/ongoing maintenance costs
- **Create long term relationships**
- **Reduce price pressure by being specified**

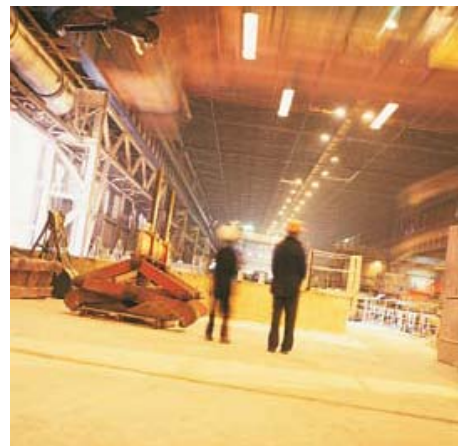

# 'Premium' Gas Detection

- There are many different applications for flammable, toxic and Oxygen gas detection.
- Industrial processes increasingly involve the use and manufacture of highly dangerous substances, particularly toxic and combustible gases.
- Inevitably, occasional escapes of gas occur, which create a potential hazard to the industrial plant, its employees and people living nearby.
- Worldwide incidents involving asphyxiation, explosions and loss of life, are a constant reminder of this problem.



# Gas Detection Applications

Honeywell



**Chemical Plants**

Probably one of the largest users of gas detection equipment are Chemical Plants. They often use a wide range of both flammable and toxic gases in their manufacturing processes or create them as by-products of the processes.

**Typical Applications:**

- Raw material storage
- Process areas
- Laboratories
- Pump rows
- Compressor stations
- Loading/unloading areas

**Typical Gases:**

**Flammable:**  
General Hydrocarbons  
**Toxic:**  
Various including Hydrogen Sulphide, Hydrogen Fluoride and Ammonia



**Oil & Gas**

The oil and gas industry covers a large number of upstream activities from the on and offshore exploration and production of oil and gas to its transportation, storage and refining. The large amount of highly flammable Hydrocarbon gases involved are a serious explosive risk and additionally toxic gases such as Hydrogen Sulphide are often present.

**Typical Applications:**

- Exploration drilling rigs
- Production platforms
- Onshore oil and gas terminals
- Refineries

**Typical Gases:**

**Flammable:**  
Hydrocarbon gases  
**Toxic:**  
Hydrogen Sulphide, Carbon Monoxide



**Power Stations**

Traditionally coal and oil have been used as the main fuel for Power Stations.

In Europe and the US most are being converted to natural gas.

**Typical Applications:**

- Around the boiler pipework and burners
- In and around turbine packages
- In coal silos and conveyor belts in older coal/oilfired stations

**Typical Gases:**

**Flammable:**  
Natural Gas, Hydrogen  
**Toxic:**  
Carbon Monoxide, SO<sub>x</sub>, NO<sub>x</sub> and Oxygen deficiency



**Waste Water Treatment Plants**

Waste Water Treatment Plants are a familiar site around many cities and towns.

Sewage naturally gives off both Methane and H<sub>2</sub>S. The 'rotten eggs' smell of H<sub>2</sub>S can often be noticed as the nose can detect it at less than 0.1 ppm.

**Typical Applications:**

- Digesters
- Plant sumps
- H<sub>2</sub>S scrubbers
- Pumps

**Typical Gases:**

**Flammable:**  
Methane, Solvent vapours  
**Toxic:**  
Hydrogen Sulphide, Carbon Dioxide, Chlorine, Sulphur Dioxide, Ozone



**Boiler Rooms**

Boiler Rooms come in all shapes and sizes. Small buildings may have a single boiler whereas larger buildings often have housing several large boilers.

**Typical Applications:**

- Flammable gas leaks from the incoming gas main
- Leaks from the boiler and surrounding gas piping
- Carbon Monoxide given off badly maintained boiler

**Typical Gases:**

**Flammable:**  
Methane  
**Toxic:**  
Carbon Monoxide



**Hospitals**

Hospitals may use many different flammable and toxic substances, particularly in their laboratories. Additionally, many are very large and have onsite utility supplies and back up power stations.

**Typical Applications:**

- Laboratories
- Refrigeration plants
- Boiler rooms

**Typical Gases:**

**Flammable:**  
Methane, Hydrogen  
**Toxic:**  
Carbon Monoxide, Chlorine, Ammonia, Ethylene Oxide and Oxygen deficiency

# Location of Detectors

- Detectors should be mounted where the gas is most likely to be present.
- Locations requiring the most protection in an industrial plant would be around gas boilers, compressors, pressurised storage tanks, cylinders or pipelines.
- Areas where leaks are most likely to occur are valves, gauges, flanges, T-joints, filling or draining connections etc.



# Sensor Location Considerations

- To detect gases that are lighter than air (e.g. Methane and Ammonia), detectors should be mounted at high level and preferably use a collecting cone
- To detect heavier than air gases (e.g. Butane and Sulphur Dioxide), detectors should be mounted at a low level
- Consider how escaping gas may behave due to natural or forced air currents. Mount detectors in ventilation ducts if appropriate
- When locating detectors consider the possible damage caused by natural events e.g. rain or flooding. For detectors mounted outdoors it is preferable to use the weather protection assembly
- Use a detector sunshade if locating a detector in a hot climate and in direct sun
- Consider the process conditions. Butane and Ammonia, for instance are normally heavier than air, but if released from a process line that is at an elevated temperature and/or under pressure, the gas may rise rather than fall
- Detectors should be positioned a little way back from high pressure parts to allow gas clouds to form. Otherwise any leak of gas is likely to pass by in a high speed jet and not be detected
- Consider ease of access for functional testing and servicing
- Detectors should be installed at the designated location with the detector pointing downwards (except optima+).
- This ensures that dust or water will not collect on the front of the sensor and stop the gas entering the detector
- When siting open path infrared devices it is important to ensure that there is no permanent obscuration or blocking of the IR beam. Short term blockage from vehicles, site personnel, birds etc can be accommodated
- Ensure the structures that open path devices are mounted to are sturdy and not susceptible to vibration

# Detector Installation Options

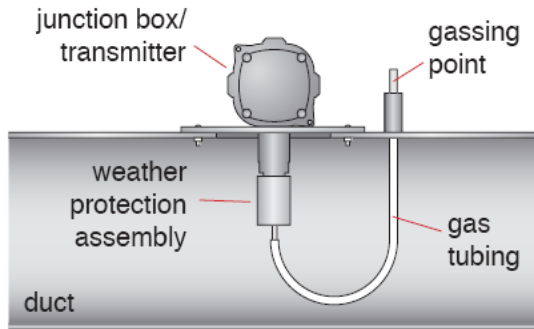

**Duct Mounted**

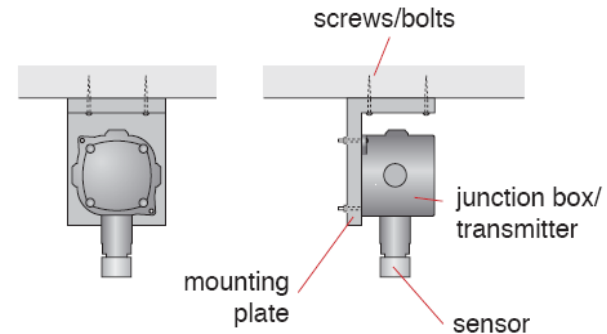

**Ceiling Mounted**

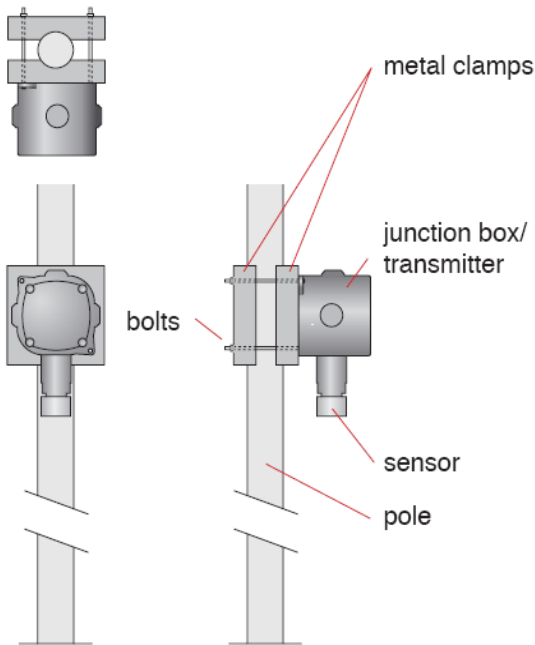

**Pipe Mounted**

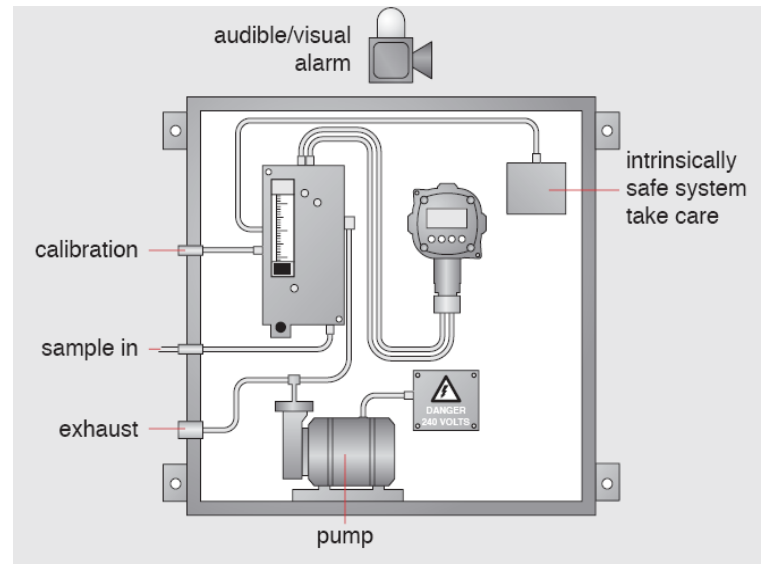

**Sampling System**

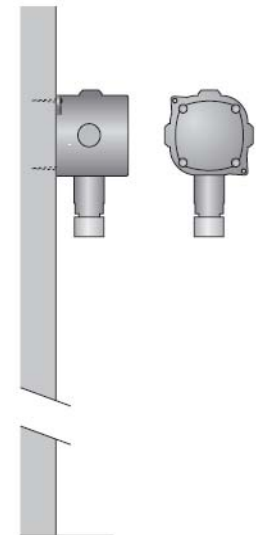

**Wall Mounted**

# Typical System Configurations

REMOTE SENSOR, LOCAL DISPLAY/GASSING

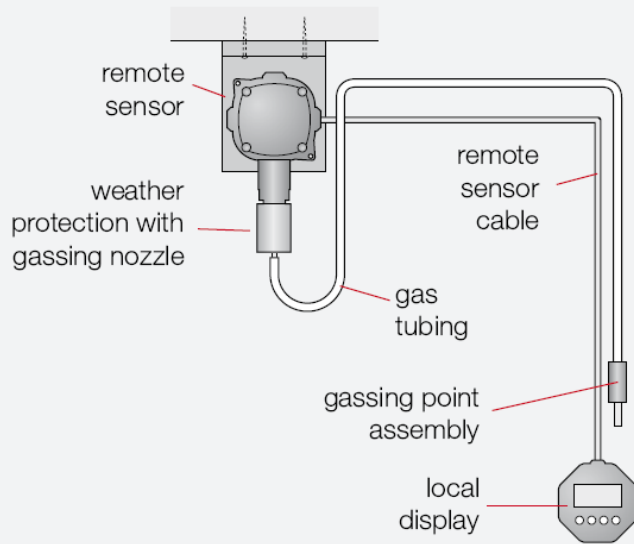

LOCALLY DRIVEN ALARM SYSTEM

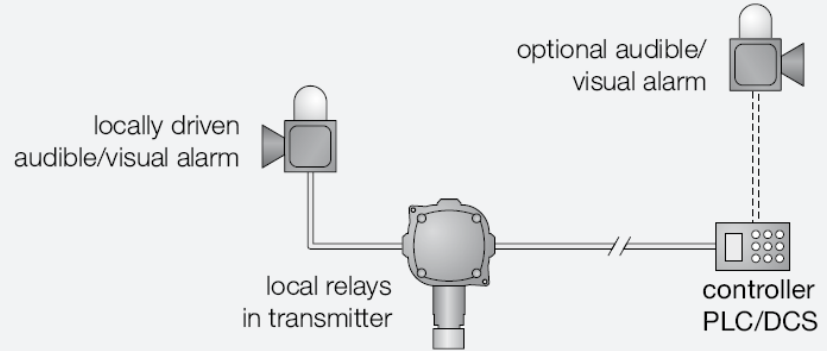

TYPICAL SENSOR/CONTROLLER SYSTEM

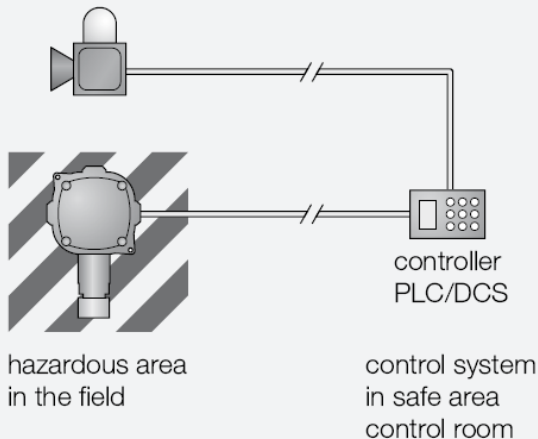

STANDALONE SYSTEM

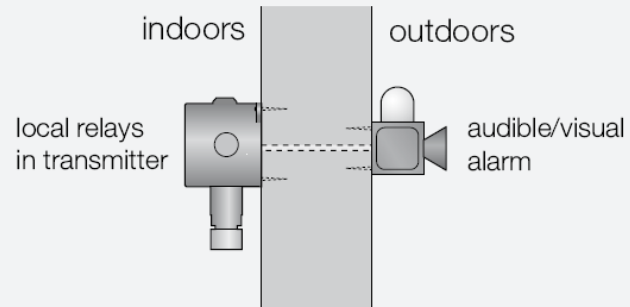

# Example of Small System

## Typical small gas detection system protecting a room

### Key



Gas Detector



Audible & Visual Alarm



Remote Reset



Fused Spur



Control Panel

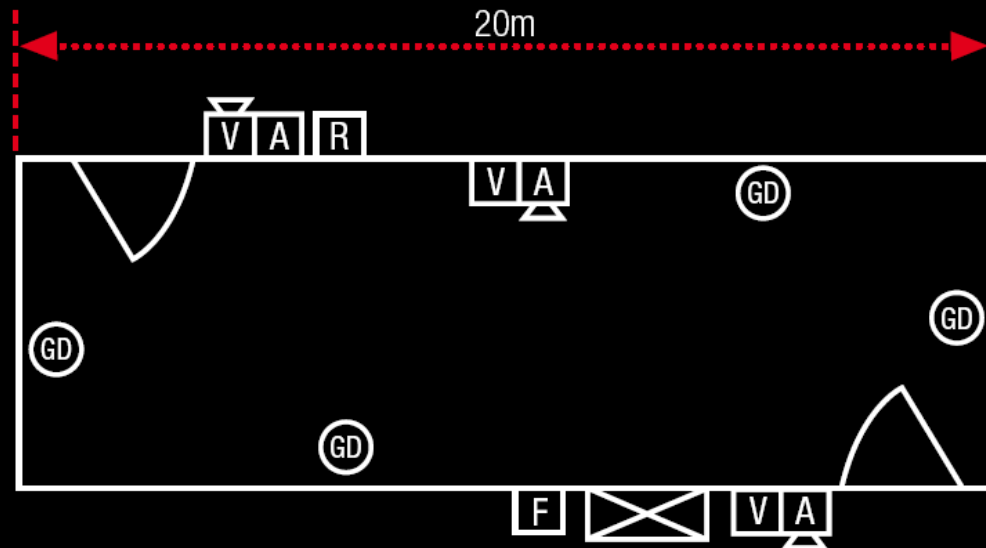

### Eg.

- Small Pump Station
- Generator House
- Normally Unmanned

### Alarms

- Warning AV prior to entry
- AV internal to evacuate (if occupied)
- Remote reset to silence alarm

# Introducing... X (inputs) 'n' X (outputs)

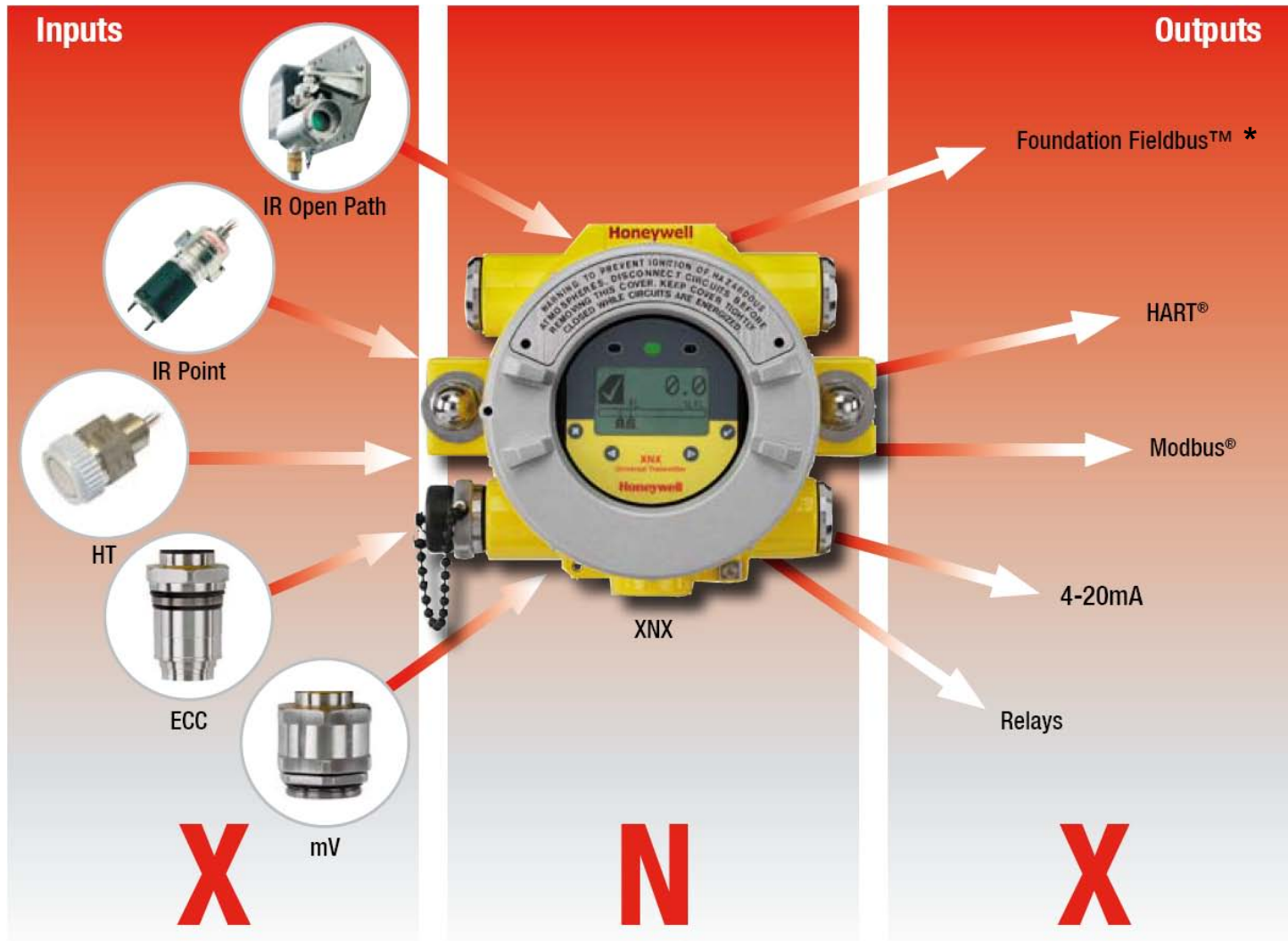

\*Pending

# XNX Product Overview



- A 3 or 4 wire sink, source or isolated 4-20mA output with HART® universal transmitter
- For use with all Honeywell Analytics gas detection technologies (catalytic, EC and IR)
- Compliant with the latest certification standards
- New range of XNX EC toxic and flammable catalytic and IR MPD sensors
- Common transmitter for all sensors
- HART® over 4-20mA as standard
- Optional relays, local HART® port, Modbus® or Foundation Fieldbus™ (pending) outputs

# Configuration to Customer Requirements

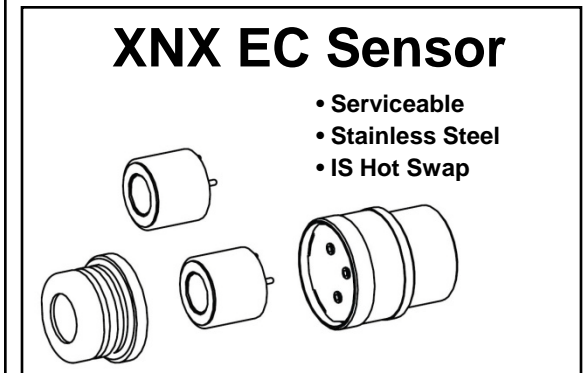
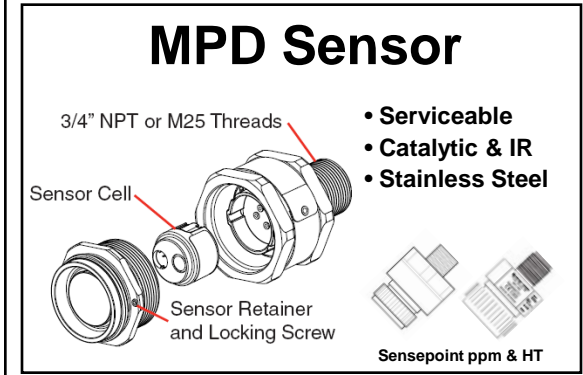
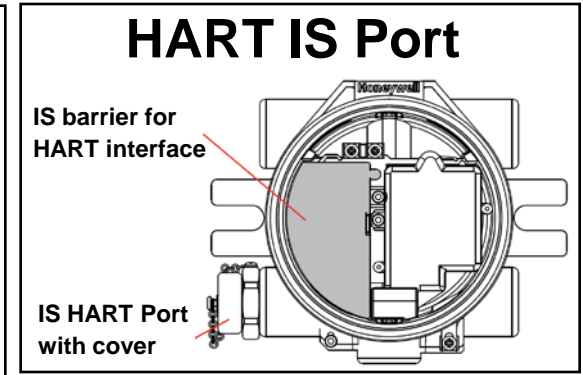
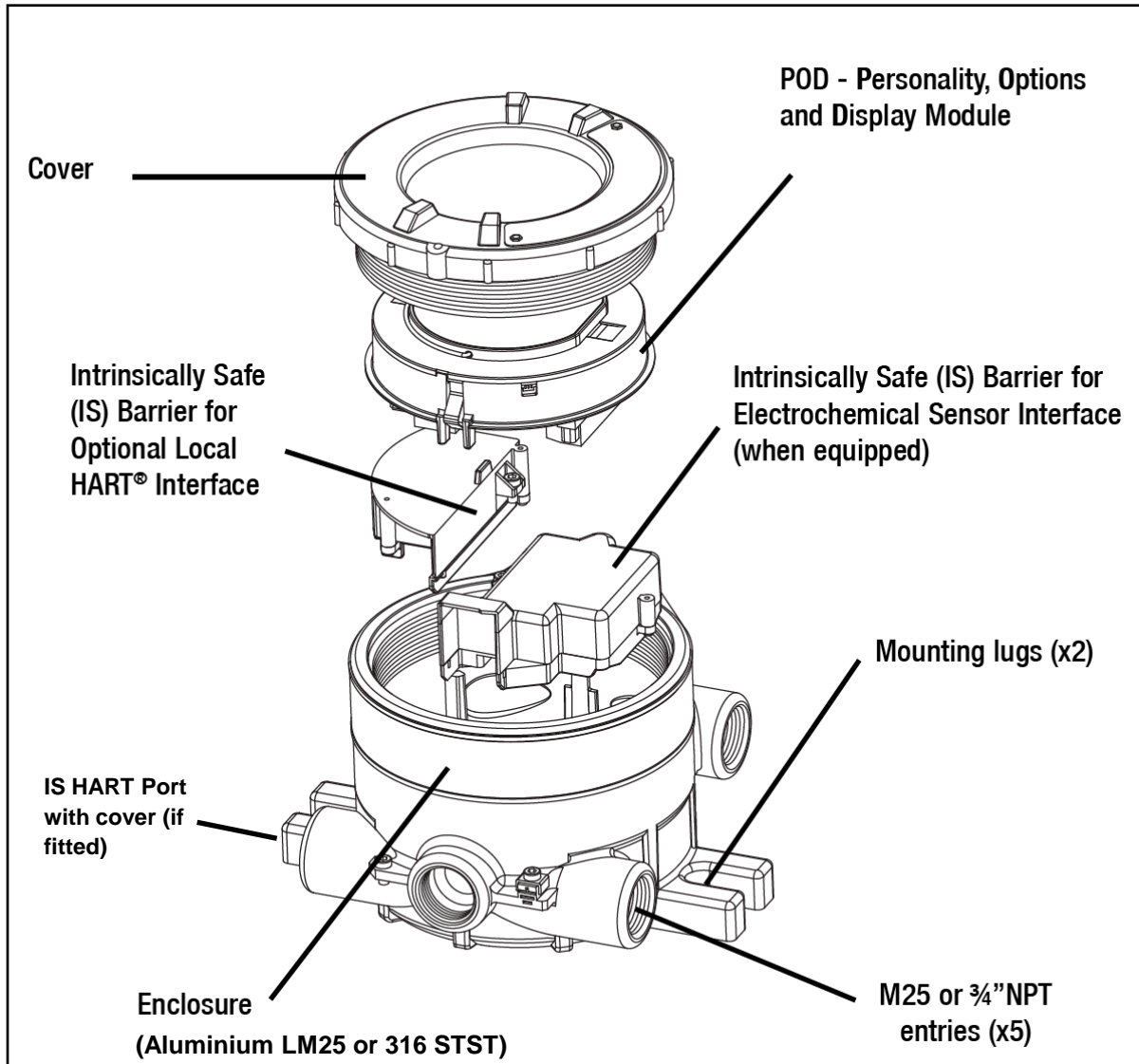

- **Compatible with full range of HA sensor technologies**

- Catalytic, Infrared and EC Sensors

- **New Multi Purpose Detector (MPD)**

- Smart sensor with plug in catalytic and IR cartridges
- Serviceable Stainless steel sensor housing
- Catalytic: Flammable gases in the range 0-100%LEL
- IR: Hydrocarbon gases in the range 0-100%LEL (0-5%Vol) and CO2 0-5%Vol



- **New XNX EC Sensor**

- Smart sensor with plug in toxic and oxygen sensor cartridges
- Serviceable Stainless steel sensor
- Intrinsically Safe sensor socket allowing 'hot swap' without the need for a hot work permit.



- **Compatible with existing HA sensors**

- Sensepoint (and 705) High Temperature and PPM (0-10%LEL or 10,000ppm)
- Searchpoint Optima and Searchline Excel



# Reflex™ Detection Cell Diagnostics

- Reflex™ a Honeywell Analytics patented fault diagnostic routine for electrochemical cells
- Reflex™ increases operator confidence of detector operability and availability
- Reflex™ initiated automatically by the transmitter
  - On power up
  - Sensor exchange
  - At 8 hourly intervals during operation
- Reflex™ checks for:
  - Cell presence
  - Cell dry out
  - Cell open circuit and cell short circuit
  - (Note: Not relevant for O<sub>2</sub> detection. Does not remove the need for regular response gas checks or calibration).



# XNX EC & MPD Sensor Gases and Ranges

XNX EC Sensor													
Gas		Cartridge P/N	Selectable Full Scale Range	Default Range	Lower Detectable Limit	Steps	Selectable Cal Gas Range	Default Cal Point	Response Time (T50) sec	Response Time (T90) sec	Accuracy*	Operating Temperature**	
												Min	Max
O <sub>2</sub>	Oxygen	XNXS01SS	n/a	25.0 %Vol	3.5 %Vol	n/a	20.9 %Vol (Fixed)	20.9 %Vol	T20 <10	<30	<+/-0.6 %Vol	-40°C / -40°F	65°C / 149°F
H <sub>2</sub> S (LoLo)	Hydrogen Sulphide	XNXSH3SS	n/a	15.0ppm	1.5ppm	n/a	30 to 70% of selected full scale range	10ppm	<20	<40	<+/-0.3ppm	-40°C / -40°F	65°C / 149°F
H <sub>2</sub> S (Lo)	Hydrogen Sulphide	XNXSH1SS	10.0 to 50.0ppm	15.0ppm	1.5ppm	0.1ppm		10ppm	<10	<30	<+/-0.3ppm	-40°C / -40°F	65°C / 149°F
H <sub>2</sub> S (Hi)	Hydrogen Sulphide	XNXSH2SS	50 to 500ppm	100ppm	3ppm	10ppm		50ppm	<10	<30	<+/-5ppm	-40°C / -40°F	65°C / 149°F
CO	Carbon Monoxide	XNXSC1SS	100 to 1,000ppm	300ppm	15ppm	100ppm		100ppm	<15	<30	<+/-2ppm	-40°C / -40°F	65°C / 149°F
SO <sub>2</sub> (Lo)	Sulphur Dioxide	XNXSS1SS	5.0 to 20.0ppm	15.0ppm	0.6ppm	5.0ppm		5.0ppm	<15	<30	<+/-0.3ppm	-40°C / -40°F	55°C / 131°F
SO <sub>2</sub> (Hi)	Sulphur Dioxide	XNXSS2SS	20.0 to 50.0ppm	50.0ppm	1.5ppm	10.0ppm		25ppm	<15	<30	<+/-0.6ppm	-40°C / -40°F	55°C / 131°F
NH <sub>3</sub> (Lo)	Ammonia	XNXSA1SS	50 to 200ppm	200ppm	6ppm	50ppm		100ppm	<60	<180	<+/-4ppm	-20°C / -4°F	50°C / 122°F
NH <sub>3</sub> (Hi)	Ammonia	XNXSA2SS	200 to 1,000ppm	1,000ppm	30ppm	50ppm		500ppm	<60	<180	<+/-20ppm	-20°C / -4°F	40°C / 104°F
CL <sub>2</sub> (Lo)	Chlorine	XNXSL2SS	n/a	5.00ppm	0.15ppm	n/a		2.0ppm	<20	<30	<+/-0.1ppm	-10°C / 14°F	55°C / 131°F
CL <sub>2</sub> (Hi)	Chlorine	XNXSL1SS	5.0 to 20.0 ppm	5.0ppm	0.6ppm	5.0 ppm		2.0ppm	<20	<30	<+/-0.1ppm	-10°C / 14°F	55°C / 131°F
ClO <sub>2</sub>	Chlorine Dioxide	XNXSX1SS	n/a	1.00ppm	0.03ppm	n/a		0.5ppm	<30	<120	<+/-0.03ppm	-20°C / -4°F	55°C / 131°F
NO	Nitrogen Monoxide	XNXSM1SS	n/a	100ppm	3ppm	n/a		50ppm	<15	<30	<+/-2ppm	-20°C / -4°F	55°C / 131°F
NO <sub>2</sub>	Nitrogen Dioxide	XNXSN1SS	5.0 to 50.0 ppm	10.0ppm	1.5ppm	5.0 ppm		5ppm	<15	<30	<+/-0.2ppm	-20°C / -4°F	55°C / 131°F
H <sub>2</sub> (Lo)	Hydrogen	XNXSG1SS	n/a	1,000ppm	30ppm	n/a		500ppm	<60	<90**	<+/-8ppm	-20°C / -4°F	55°C / 131°F
H <sub>2</sub> (Hi)	Hydrogen	XNXSG2SS	n/a	10,000ppm	300ppm	n/a		5000ppm	<15	<30	<+/-150ppm	-20°C / -4°F	55°C / 131°F
HF	Hydrogen Fluoride	XNXSF1SS	n/a	12.0ppm	0.4ppm	n/a		5.0ppm	120	<240	<+/-0.5ppm	-20°C / -4°F	55°C / 131°F
PH <sub>3</sub>	Phosphine	XNXSP1SS	n/a	1.20ppm	0.04ppm	n/a		0.5ppm	<15	<30	<+/- 0.02ppm	-20°C / -4°F	55°C / 131°F

XNX Multi Purpose Detector (MPD)												
Sensor Type	Target Gas	User Selectable Full Scale Range	Default Range	Steps	User Selectable Cal Gas Range	Primary Cal Gas	Default Cal Point	Response Time (T90) secs	Accuracy	Operating Temperature		
										Min	Max	
IR CO2	Carbon Dioxide	1.00 to 5.00%Vol	5.00%Vol	1.00%Vol	1.50 to 3.5%Vol	Carbon Dioxide	2.5%Vol	<60	±5% of FS	-20°C/-4°F	+50°C/+122°F	
IR CH4	Methane	1.00 to 5.00%Vol	5.00%Vol	1.00%Vol	1.50 to 3.5%Vol	Methane	2.5%Vol	<60	±5% of FS	-20°C/-4°F	+50°C/+122°F	
		20 to 100%LEL	100%LEL	10%LEL	30 to 70%LEL		50%LEL		±5% of FS			
IR HC	Hydrocarbons	20 to 100%LEL	100%LEL	10%LEL	30 to 70%LEL	Propane	50%LEL	<60	±5% of FS	-20°C/-4°F	+50°C/+122°F	
Catalytic	Flammables	20 to 100%LEL	100%LEL	10%LEL	30 to 70%LEL	Methane	50%LEL	<30	±5% of FS	-40°C/-40°F	+65°C/+149°F	

**NOTES**

Data taken at ambient conditions of 20°C, 50% RH. Data represents typical values of freshly calibrated sensors without optional accessories attached. \*Accuracy at 10% of default full scale (typical A1 alarm) of applied gas, or minimum (whichever is greater). Measured using calibration flow housing at calibration flow rate. Performance figures are applicable between 10 and 90% of full scale. Performance figures are measured by test units calibrated at 50% of full scale. Contact Honeywell Analytics for any additional data or details. \*\*Standard temperature range for XNX EC Sensors is -20°C to +55°C. Extended temperature range for the XNX EC Sensors is -40°C to +65°C. Accuracy is ±30% of applied gas from -20°C to -40°C and +55°C to +65°C. Operating the XNX EC Sensors at extended temperature ranges for a prolonged time period exceeding 12 hours may cause deterioration in sensor performance and shorter sensor life. Contact Honeywell Analytics for any additional data or details.

- **Materials**

- **Painted Aluminium LM25**
  - ◆ General Industrial applications
- **Painted Stainless Steel 316**
  - ◆ Offshore and harsh environments
  - ◆ Food and beverage markets

- **Hazardous area certified**

- **ATEX, IECEx, UL and cUL**

- **Mounting**

- **2 x Integral mounting lugs**
- **Suitable for M10-12 bolts**
- **Optional Pipe, Ceiling or Duct mounting options (see following slides)**

- **Entries**

- **5 x M25 (ATEX/IECEx version)**
- **5 x ¾" NPT (UL/CSA versions)**
- **Suitable blanking plugs also supplied**
  - ◆ Must be suitably sealed to maintain IP rating

## Outline transmitter dimensions:

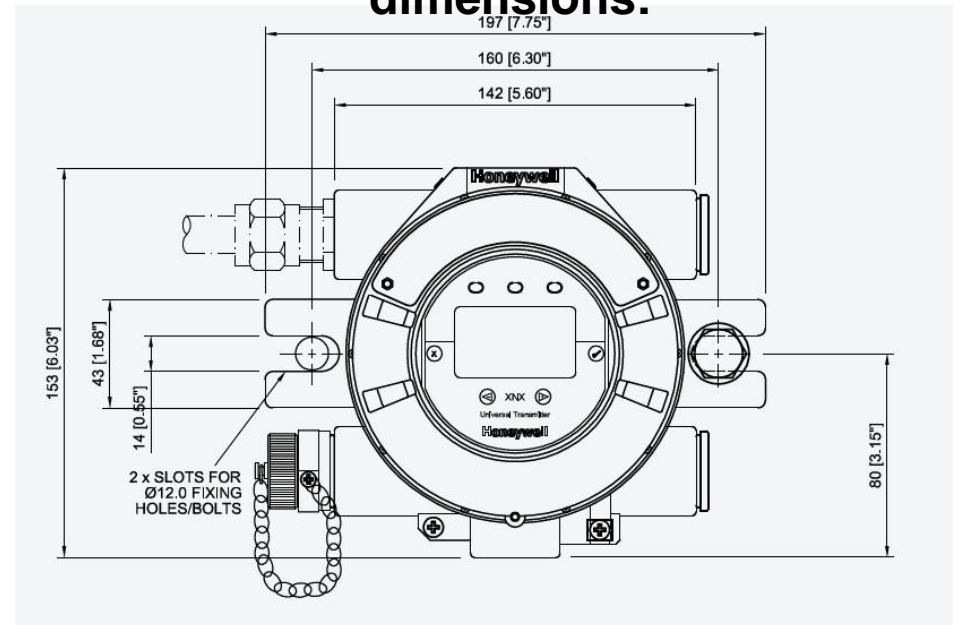

# XNX Optional Accessories

- **Pipe mounting kit**

- The transmitter may be fixed directly to a vertical pipe/structure
- Suitable for pipes Ø50.0-100.0mm (Ø2" to 6").

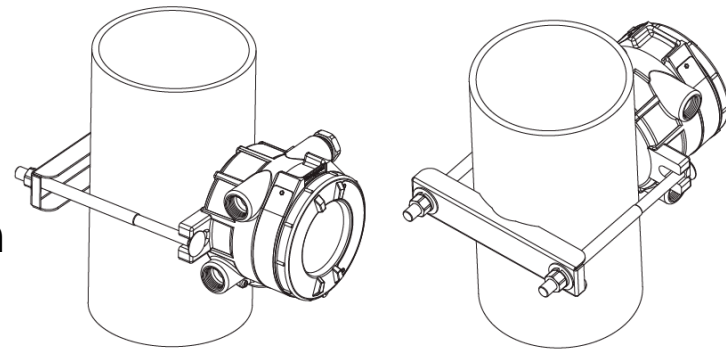

- **Ceiling mounting Bracket**

- Allows XNX to be mounted to a ceiling
- Includes: 2 x Stainless Steel Ceiling Mount Brackets, bolts and nuts.

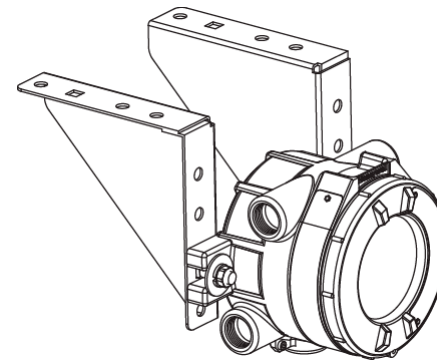

- **Remote EC sensor mounting kit**

- Allows the XNX EC sensors to be remotely mounted via an IS cable kit, up to 15 meters (50 feet) from the transmitter.
- Includes 15 meters of shielded cable, cable glands and remote terminal box.
  - ◆ The cable can be cut to the required length and terminated at the remote terminal box

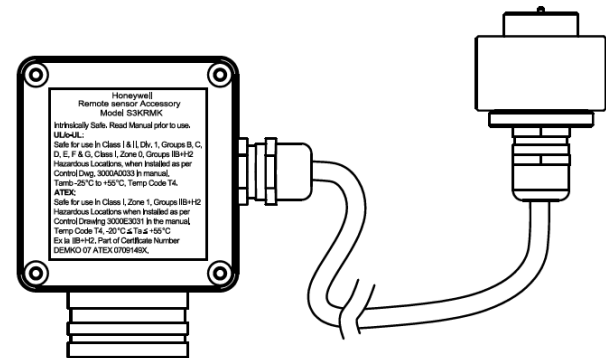

# XNX Optional Accessories

- **Duct mounting kit**

- Enables detection within ventilation duct with transmitter external to duct
- As standard for CO, H2 and H2S EC sensors
- Separate additional MPD sensor adaptor for flammable and Hydrocarbon gases
- **Square/rectangular ducts**
  - ◆ Minimum 1mm (0.04") duct wall thickness
- **External gas inlet port**
  - ◆ Recommended for bump test only
  - ◆ Use calibration cup for calibration
  - ◆ Suitable for 6mm (1/4") ID tubing

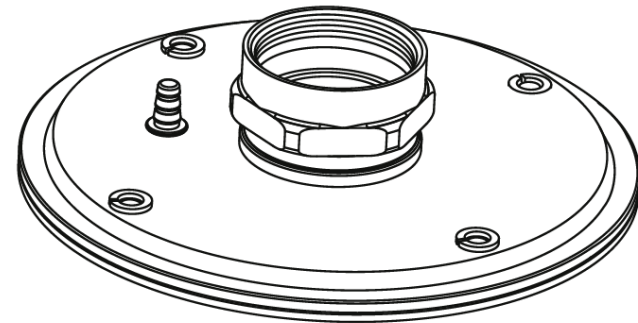

- **Other sensor accessories**

- A wide range of weather protection assemblies, flow housings, collecting cones and calibration adaptors are available depending on the type of sensor used.

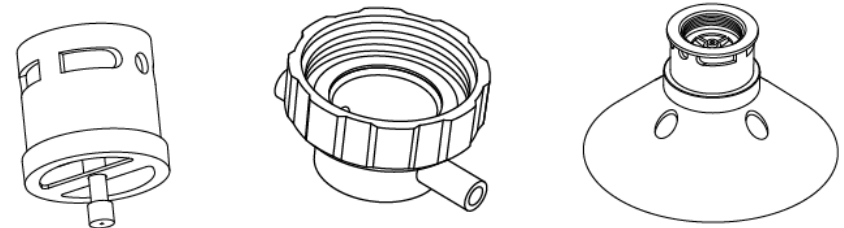

# XNX with MPD Sensor Mechanical Data

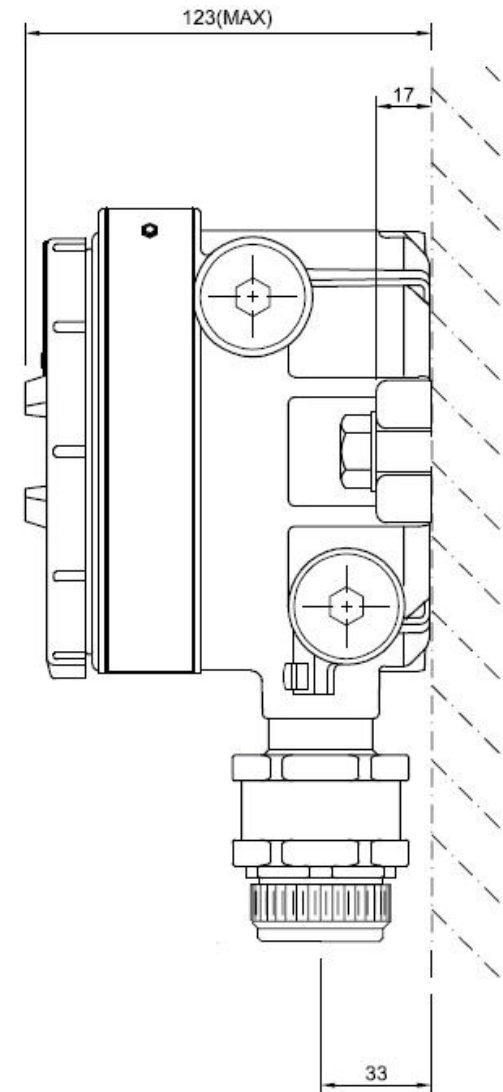
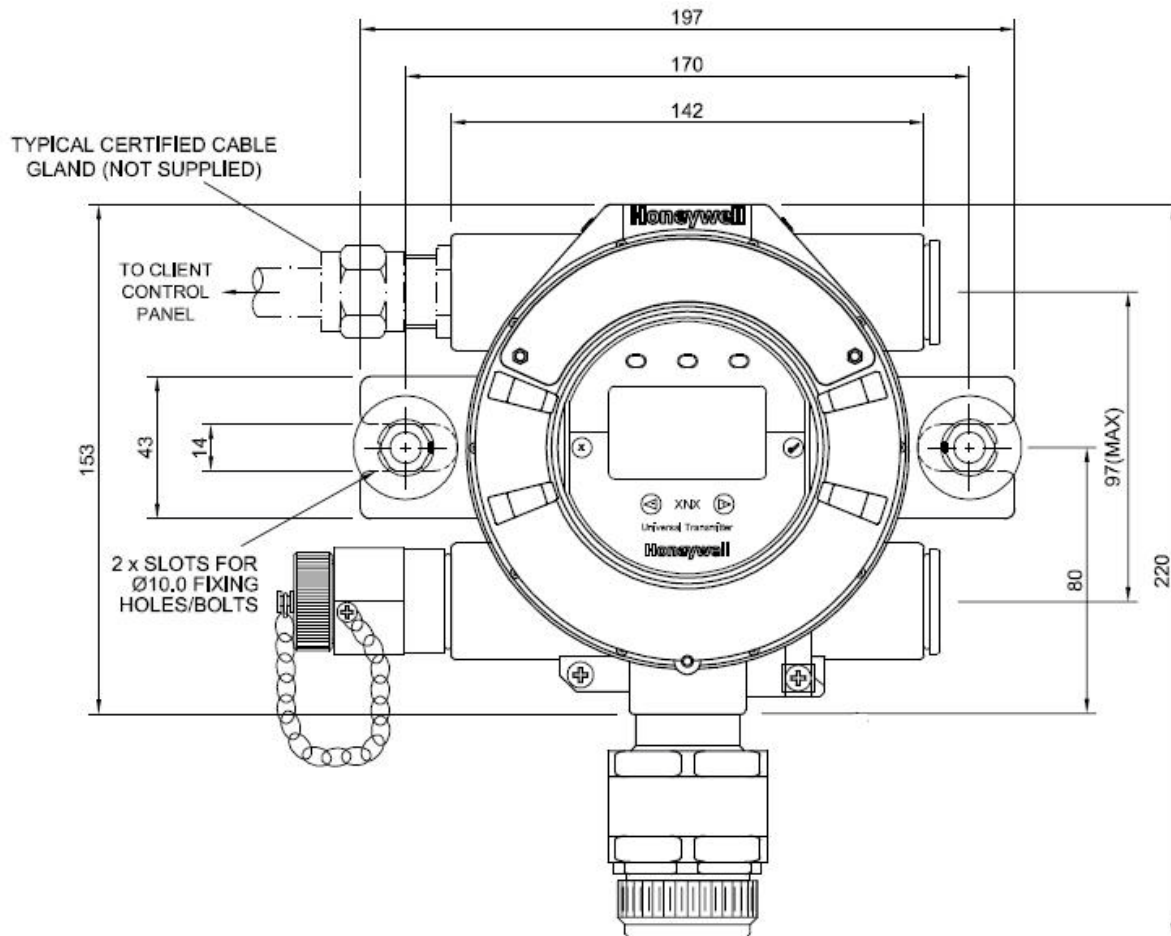

ALL DIMENSIONS IN mm. 1" = 25.4mm

# XNX with EC Sensor Mechanical Data

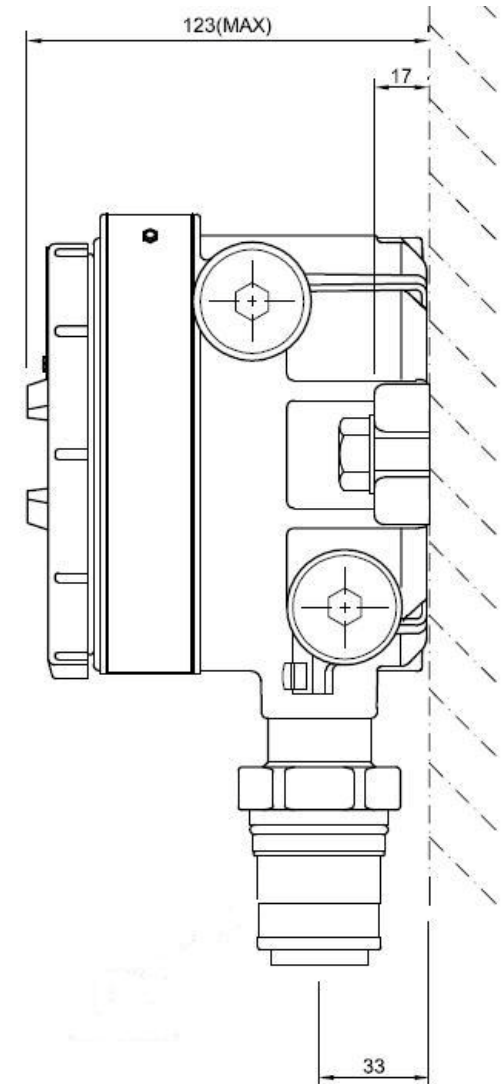
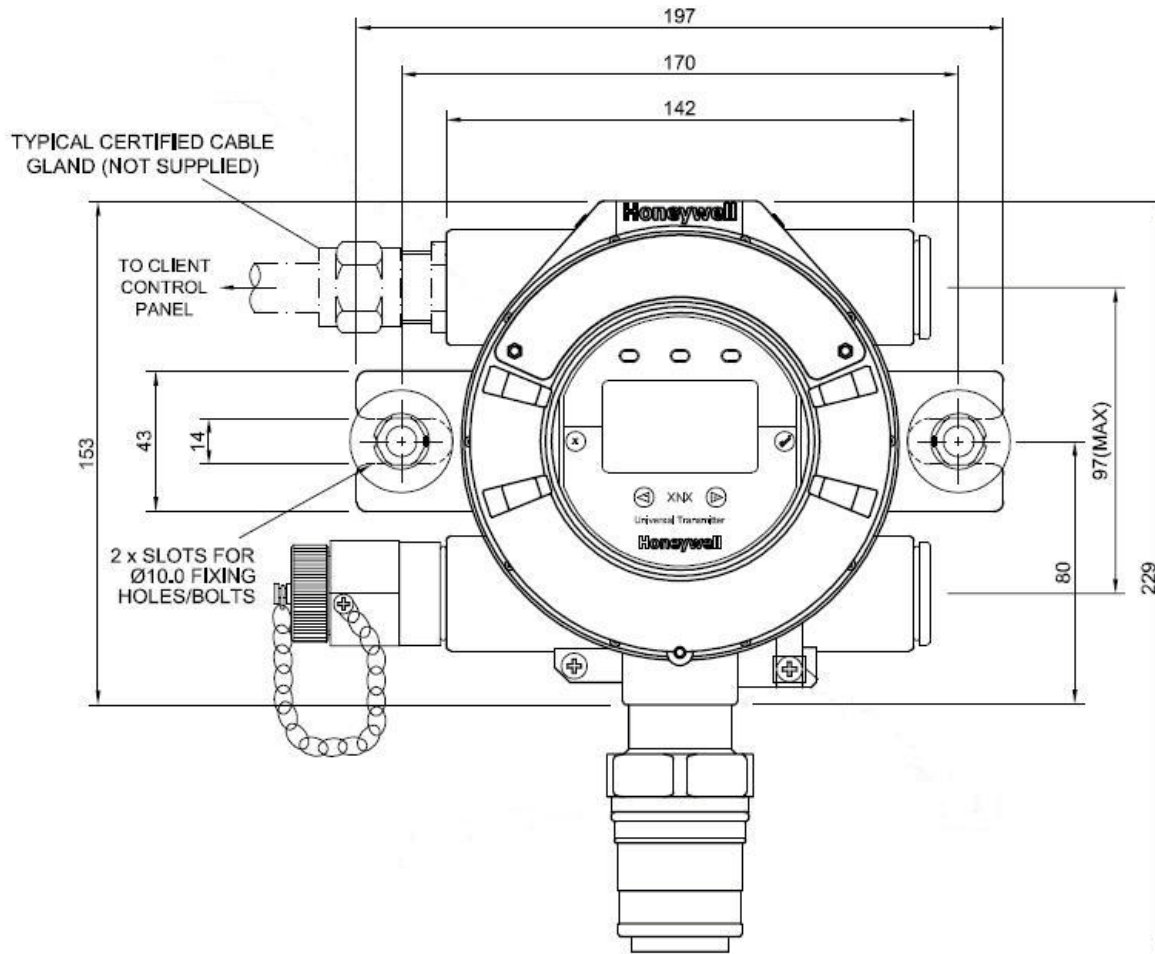

ALL DIMENSIONS IN mm. 1" = 25.4mm

# XNX with S.Point PPM Sensor Mechanical Data

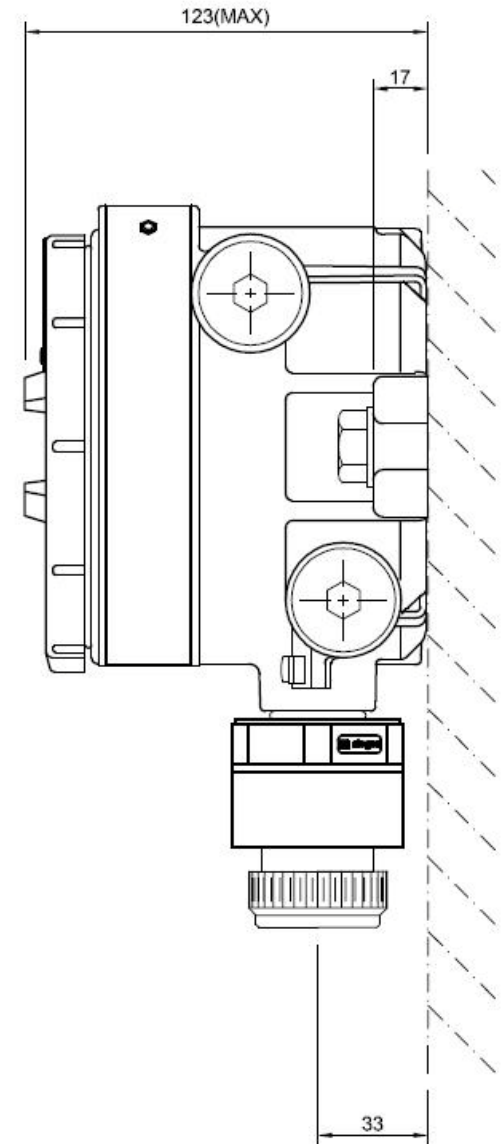
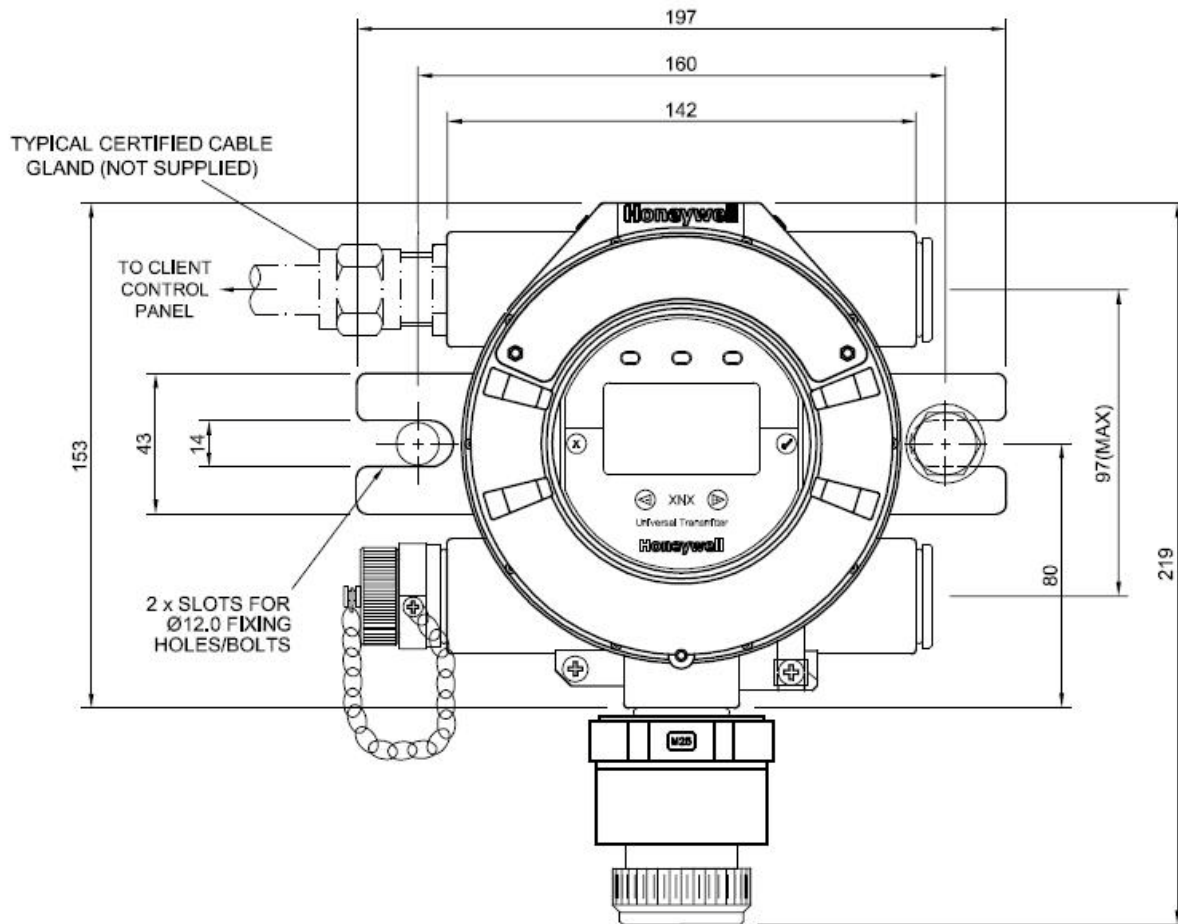

ALL DIMENSIONS IN mm. 1" = 25.4mm

# XNX with Optima Plus Sensor Mechanical Data

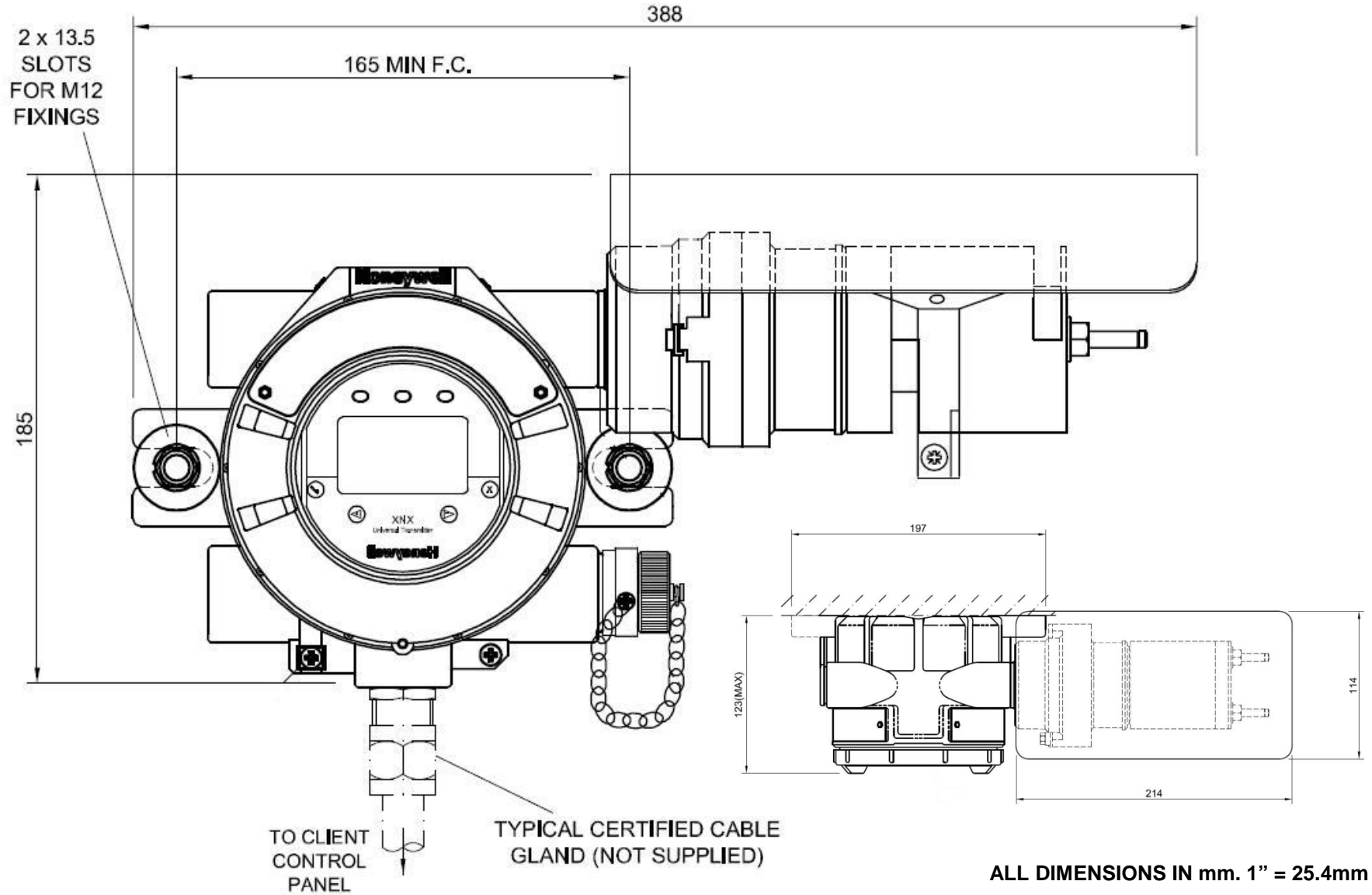

# XNX with Optima Plus Sensor Mechanical Data



## Pipe/Pole Mounting

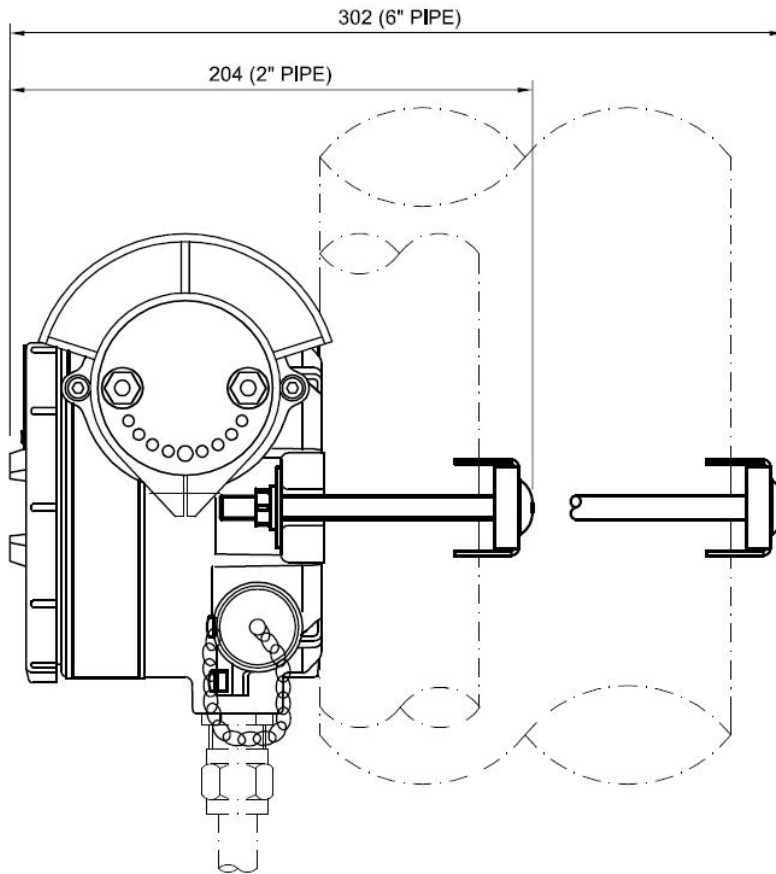

## Ceiling Mounting

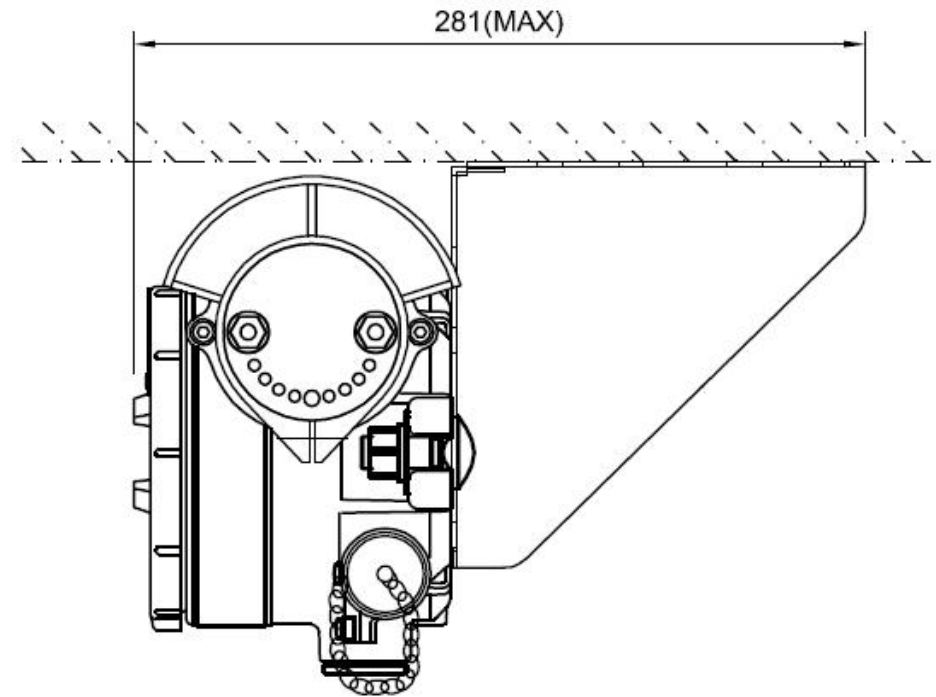

ALL DIMENSIONS IN mm. 1" = 25.4mm

# XNX with Searchline Excel Mechanical Data

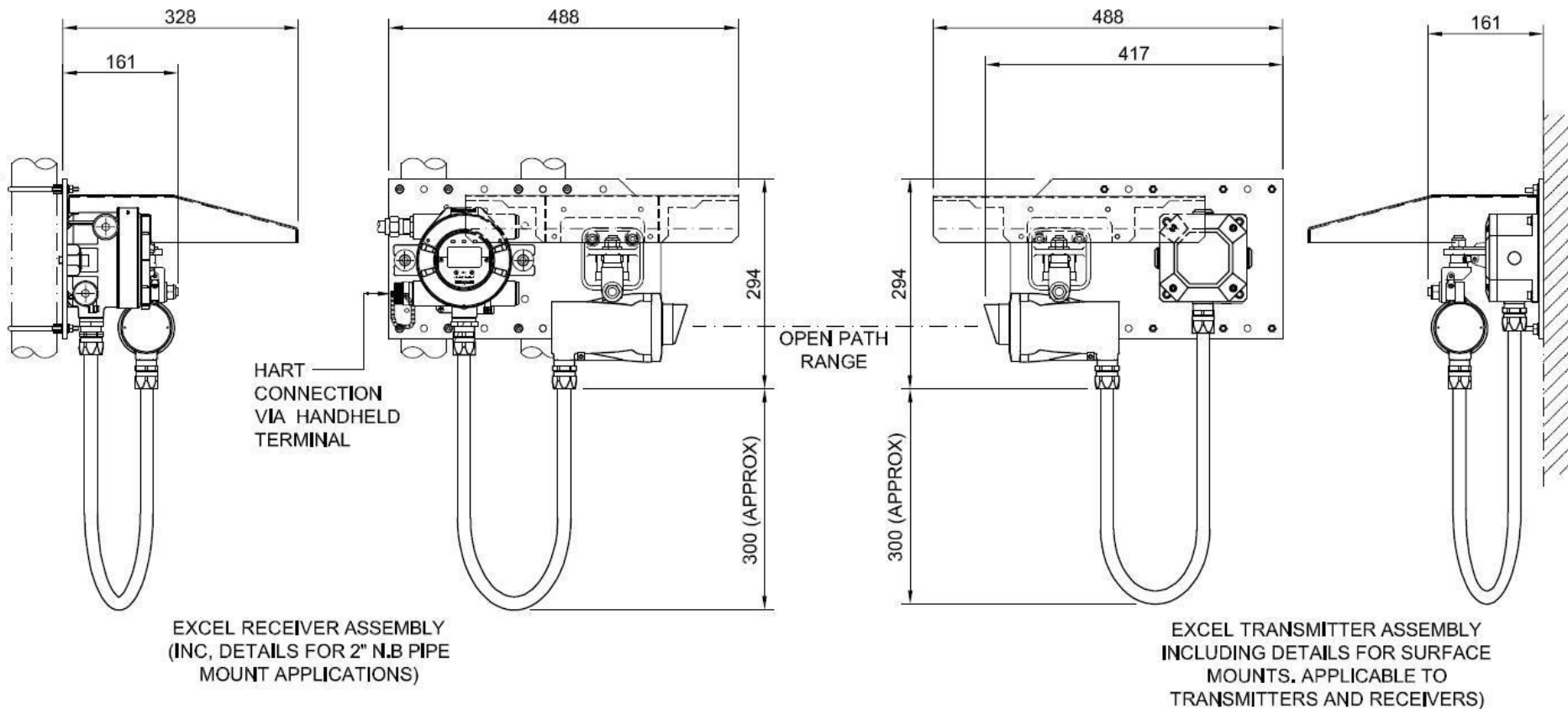

ALL DIMENSIONS IN mm. 1" = 25.4mm

# XNX with Remote S.Point HT Sensor Mechanical Data

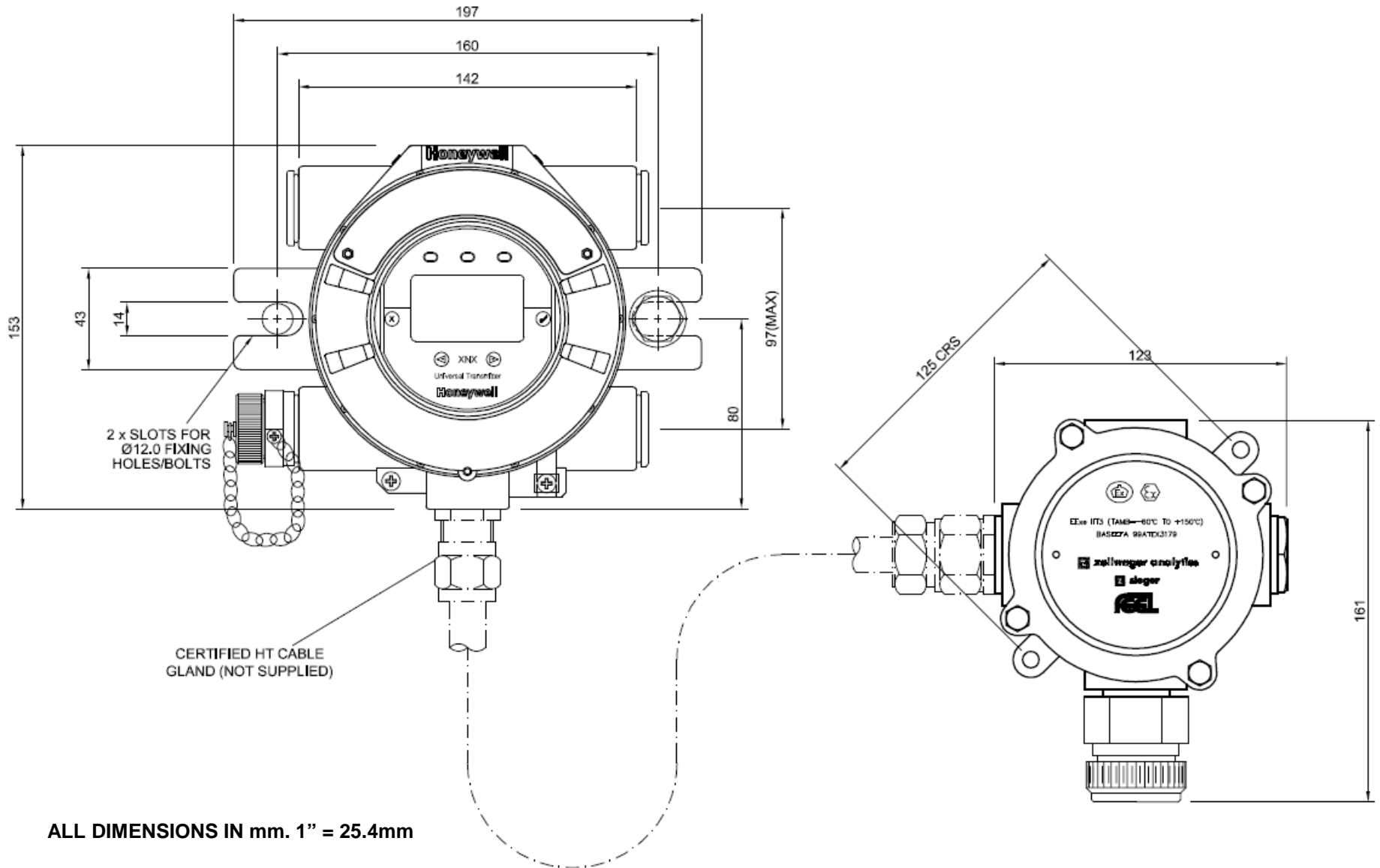

ALL DIMENSIONS IN mm. 1" = 25.4mm

# XNX with Remote 705HT Sensor Mechanical Data

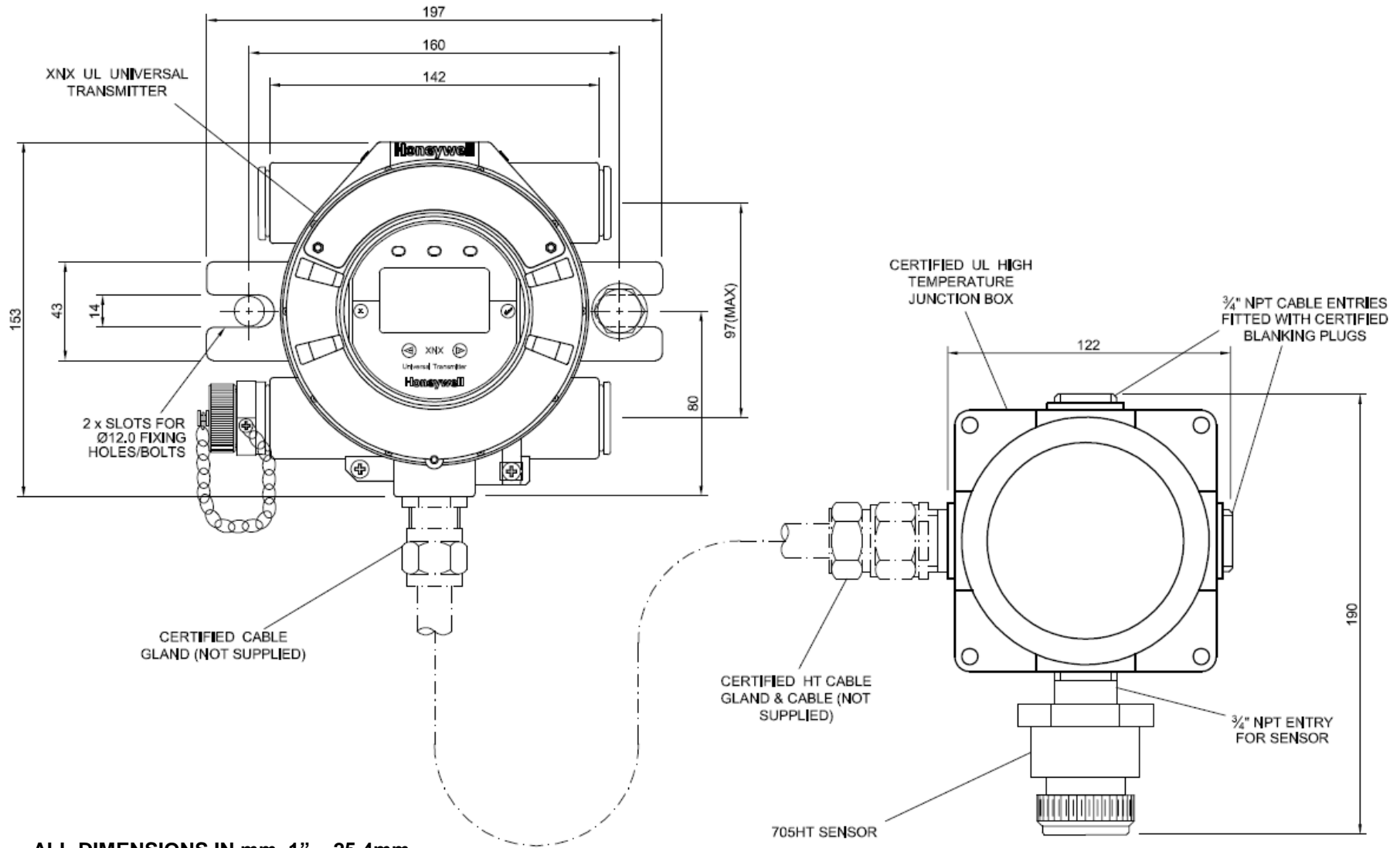

ALL DIMENSIONS IN mm. 1" = 25.4mm

# XNX Electrical Data

- **Output**

- **Industrial standard 4-20mA**
  - ◆ Sink or source switch selectable
- **Over range 22mA**
- **Fault  $\geq 0.0 < 1.0$  mA**
- **Inhibit (Selectable)**
  - ◆ Flam/Toxic: 2mA or 4mA  
(Oxygen 2mA or 17.4mA)

- **Supply voltage**

- **16 to 32Vdc (24Vdc nominal)**

- **Power consumption (max)**

- **XNX EC (Toxic) 6.2W**
- **XNX mV (Flam) 6.5W**
- **XNX IR with Optima Plus 9.7W**
- **XNX IR with Excel receiver 13.2W**

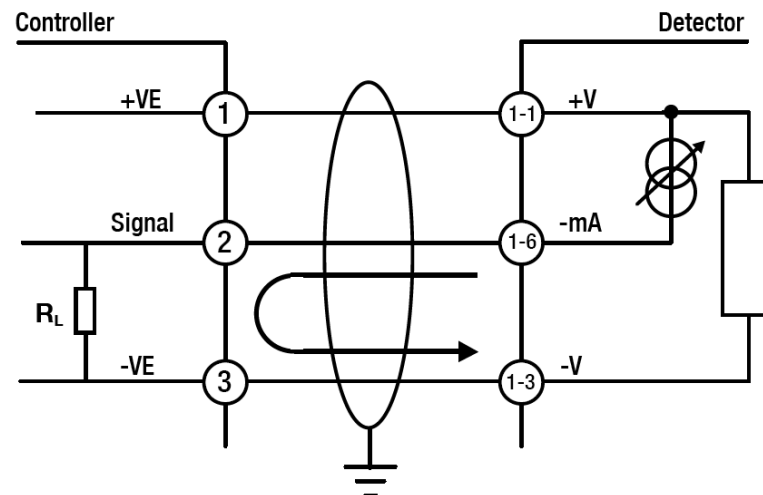

XNX Source Configuration

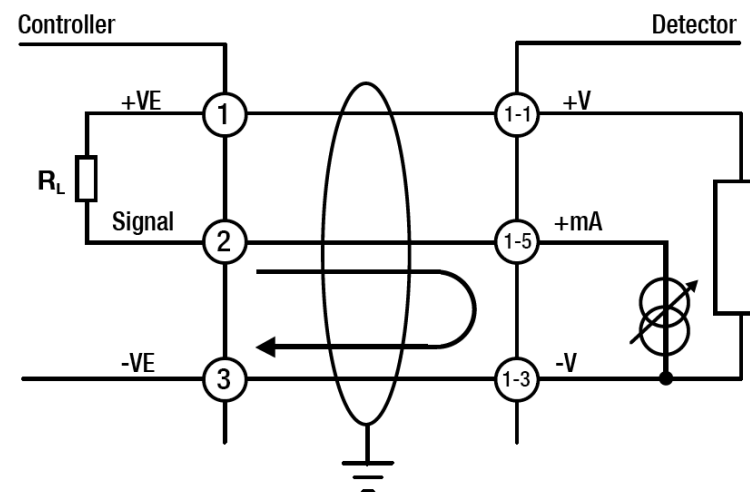

XNX Sink Configuration

NOTE: To avoid ground loops, terminate screen at detector or controller, not both

# XNX Electrical Data

- **Wiring**

- Suitable mechanically protected cable/conduit and glands
- **3 or 4 core plus screen**
  - ◆ 90% coverage preferred
- **0.5mm<sup>2</sup> to 2.5mm<sup>2</sup> (Approx. 20 to 14AWG) cable**
  - ◆ Ensure min required voltage at transmitter is 18Vdc

- **Maximum cable lengths**

- Max. cable length between a controller and detector is dependent upon:
  - ◆ The minimum guaranteed supply voltage from the controller
  - ◆ The minimum operating voltage of the detector
  - ◆ The maximum current draw of the detector
  - ◆ The input impedance of the controller
  - ◆ The resistance of the cable

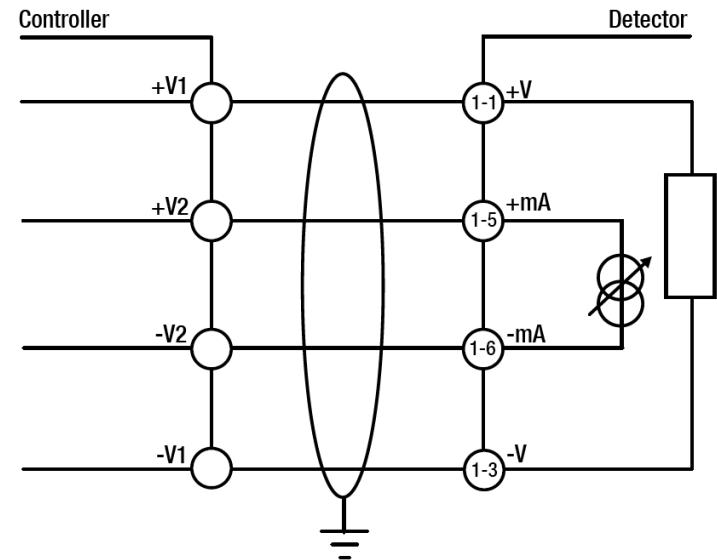

**XNX Isolated Configuration**





NOTE: To avoid ground loops, terminate screen at detector or controller, not both

Cable Size	Max Cable Distance Meters (Feet)
1.0mm <sup>2</sup> (18AWG*)	347m (1140')
1.5mm <sup>2</sup> (16AWG*)	551m (1810')
2.0mm <sup>2</sup> (14 AWG*)	880m (2890')
2.5mm <sup>2</sup> (12AWG*)	1408m (4620')

- The typical maximum cable length table above is for an XNX mV with an MPD catalytic sensor or an XNX EC with an XNX EC sensor fitted.
- It also assumes a single transmitter being powered from a PSU. Refer to the manual for examples of other variants and cable topology.

# XNX Personalities

- **XNX has 3 basic personalities (configurations)**
  - **XNX mV for all mV input sensors**
    - ◆ MPD, Sensepoint HT, PPM, and model 705
  - **XNX EC for use with the new XNX EC sensor**
    - ◆ IS Hot swap Toxic and Oxygen sensors
  - **XNX IR for use with IR open path and point detectors**
    - ◆ Searchline Excel and Searchpoint Optima Plus

Personality	XNX mV					XNX EC	XNX IR	
Sensors Supported	MPD Flammable Catalytic	MPD Flammable Infrared (Flam and CO <sub>2</sub> )	Sensepoint HT (High Temperature)	Sensepoint PPM	705 HT (High Temperature)	XNX Toxic and Oxygen Sensors	Searchpoint Optima Plus	Searchline Excel
Product Image								

# XNX Terminals (POD)

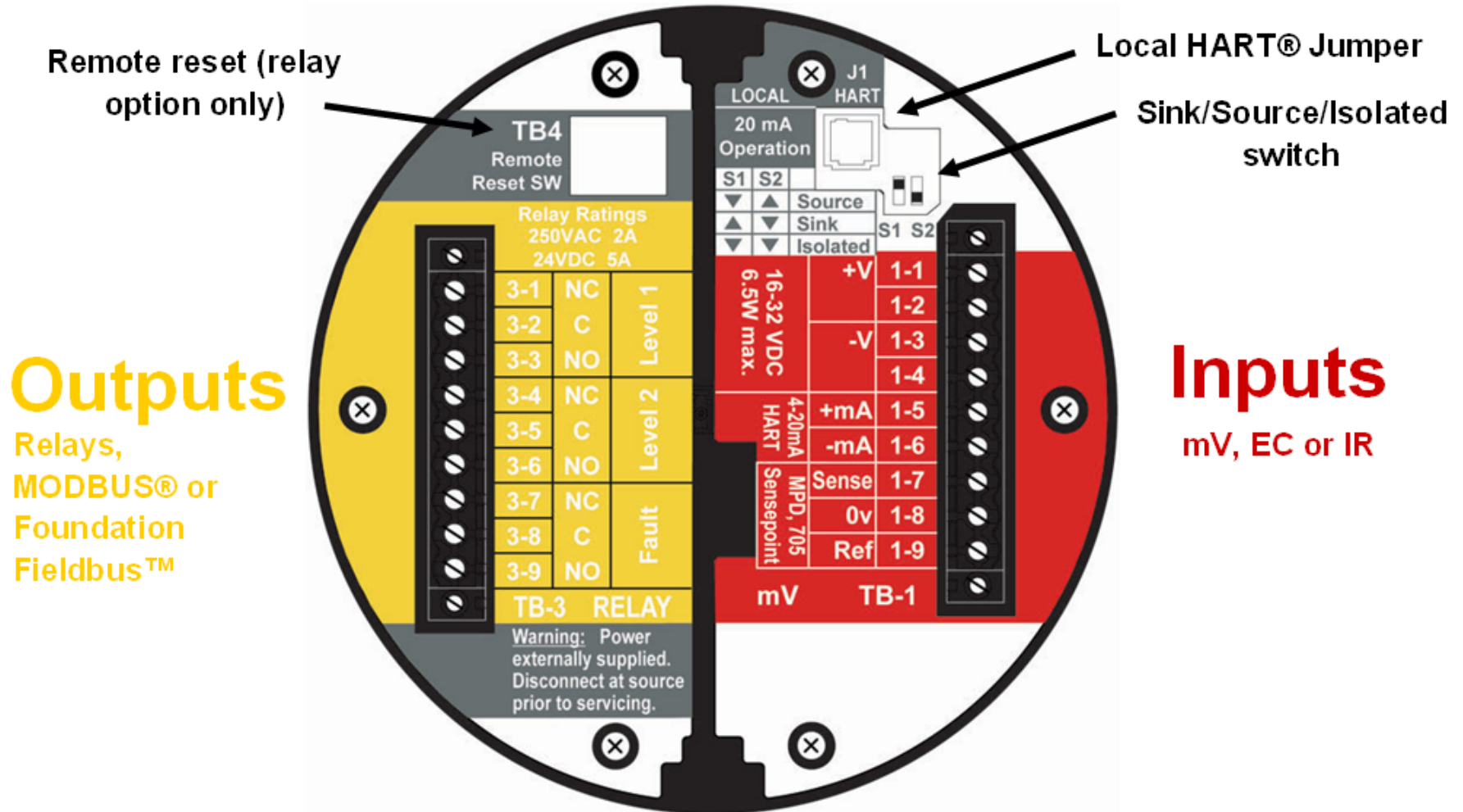

Example POD with mV Input and Relay Output

# XNX Terminals (POD)

## Options Boards

Terminal	Relay		Modbus RTU		Foundation Fieldbus*	
	Marking	Connection	Marking	Connection	Marking	Connection
3-1	NC	Alarm 1 Normally Closed	+	Power In +	F+	FF Data In +
3-2	C	Alarm 1 Common	+	Power Out +	F+	FF Data Out +
3-3	NO	Alarm 1 Normally Open	-	Power In -	F-	FF Data In -
3-4	NC	Alarm 2 Normally Closed	-	Power Out -	F-	FF Data Out -
3-5	C	Alarm 2 Common	A	Modbus A In	FS	FF Shield In
3-6	NO	Alarm 2 Normally Open	A	Modbus A Out	SS	FF Shield Out
3-7	NC	Fault Normally Closed	B	Modbus B In		
3-8	C	Fault Common	B	Modbus B Out		
3-9	NO	Fault Normally Open	S	Modbus Drain In		
3-10	-	-	S	Modbus Drain Out		
TB4	Marking	Connection				
		Remote reset switch				
		Remote reset switch				

\*Pending

	S1	S2
Source	Down	Up
Sink	UP	Down
Isolated	Down	Down

# XNX Terminals (POD)

Personality Boards				
Terminal	Marking			Connection
<b>TB1</b>	<b>EC</b>	<b>mV</b>	<b>IR</b>	
1-1	+V	+V	+V	+VE Supply (18-32VDC)
1-2	+V	+V	+V	+VE Supply (18-32VDC)*
1-3	-V	-V	-V	-VE supply (0VDC)
1-4	-V	-V	-V	-VE supply (0VDC)*
1-5	+mA	+mA	+mA	Current & HART output 4-20mA +
1-6	-mA	-mA	-mA	Current & HART output 4-20mA -
1-7	-	Sense	+Ir	Sensor Connection
1-8	-	0V	-Ir	Sensor Connection
1-9	-	Ref	Sig	Sensor Connection
<b>TB2</b>	<b>EC</b>	<b>mV</b>	<b>IR</b>	
2-1	-	-	Com A	Optima/Excel Modbus A Comms
2-2	-	-	Com B	Optima/Excel Modbus B Comms

\*Terminal block jumper required

# XNX Electrical Data

## EC version POD

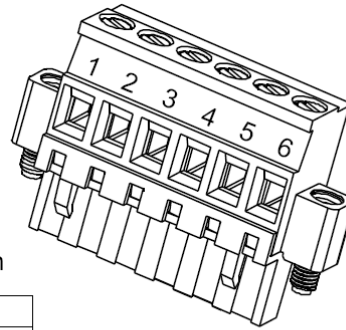
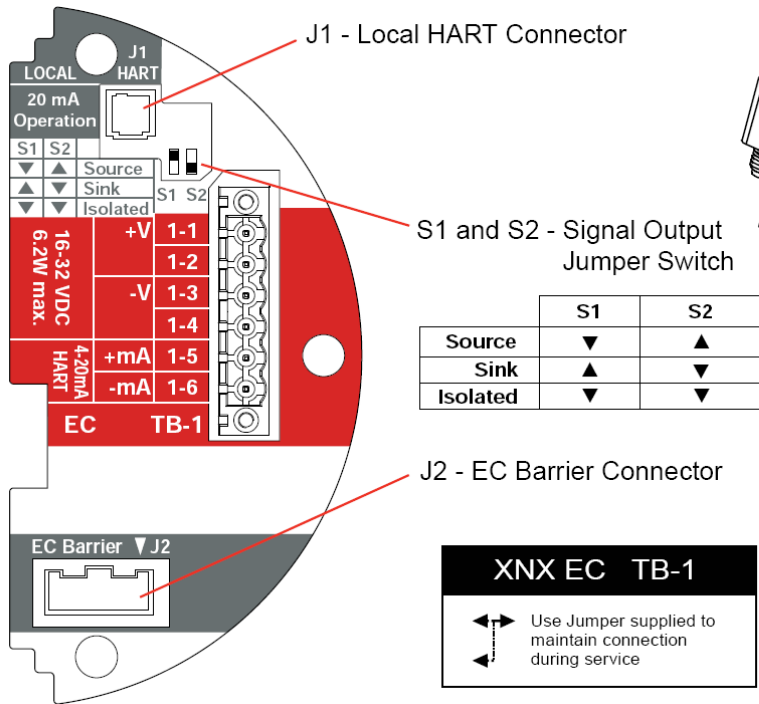

Position	EC
<b>TB1</b>	
1	+24
2	
3	0v
4	

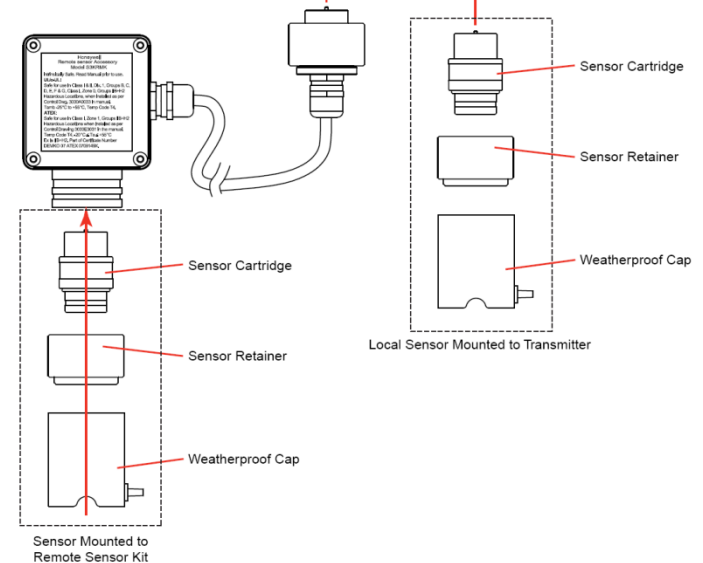
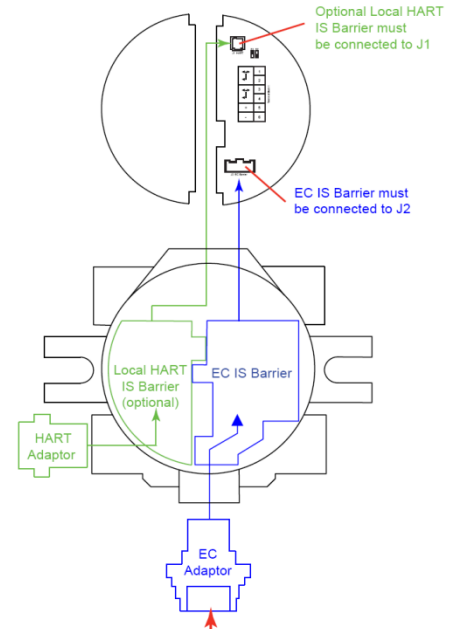

## mV version POD

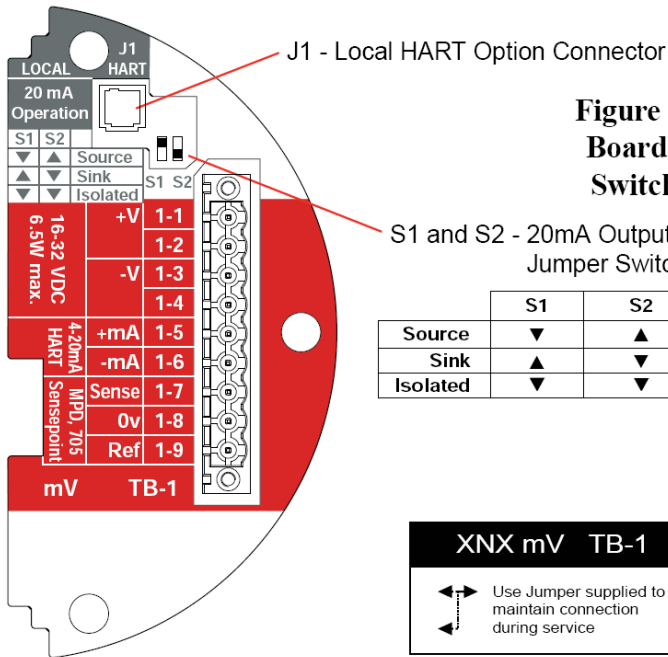

**Figure 2-15. XNX mV Personality Board Terminal Blocks, Jumper Switches and Wire Color Chart**

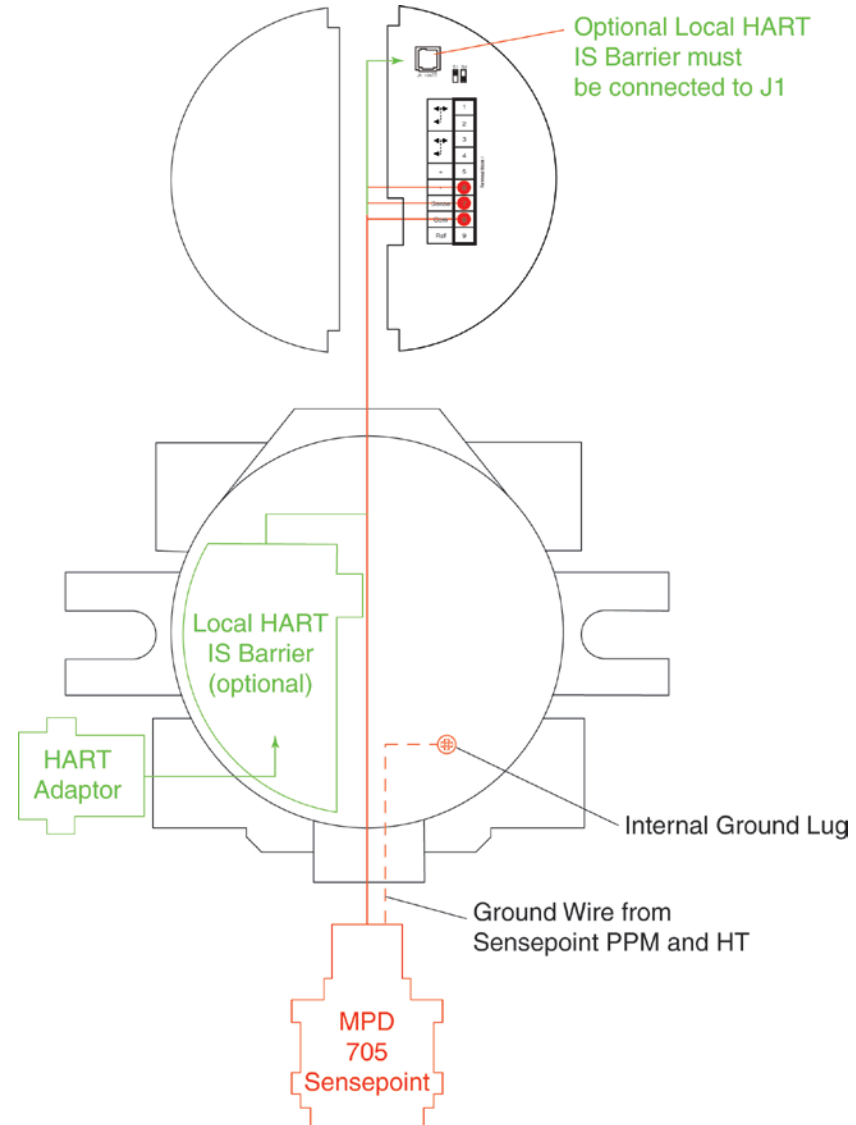
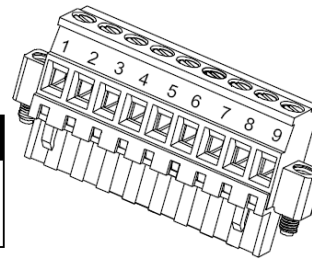

# XNX Electrical Data

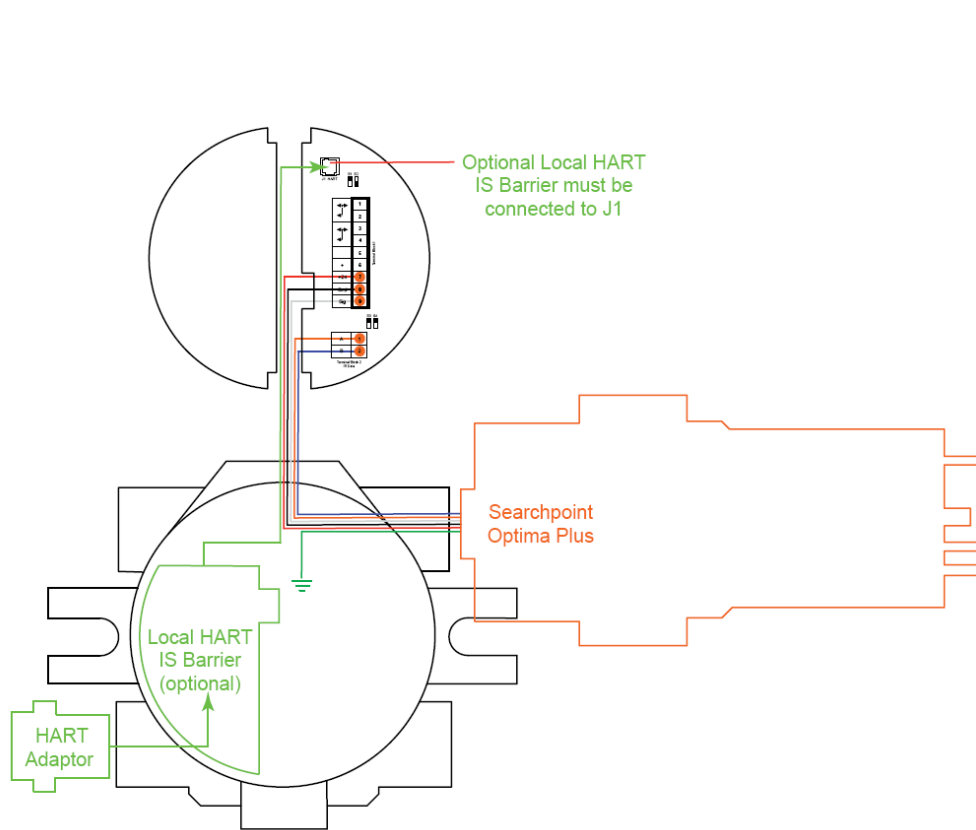

## Searchpoint Optima

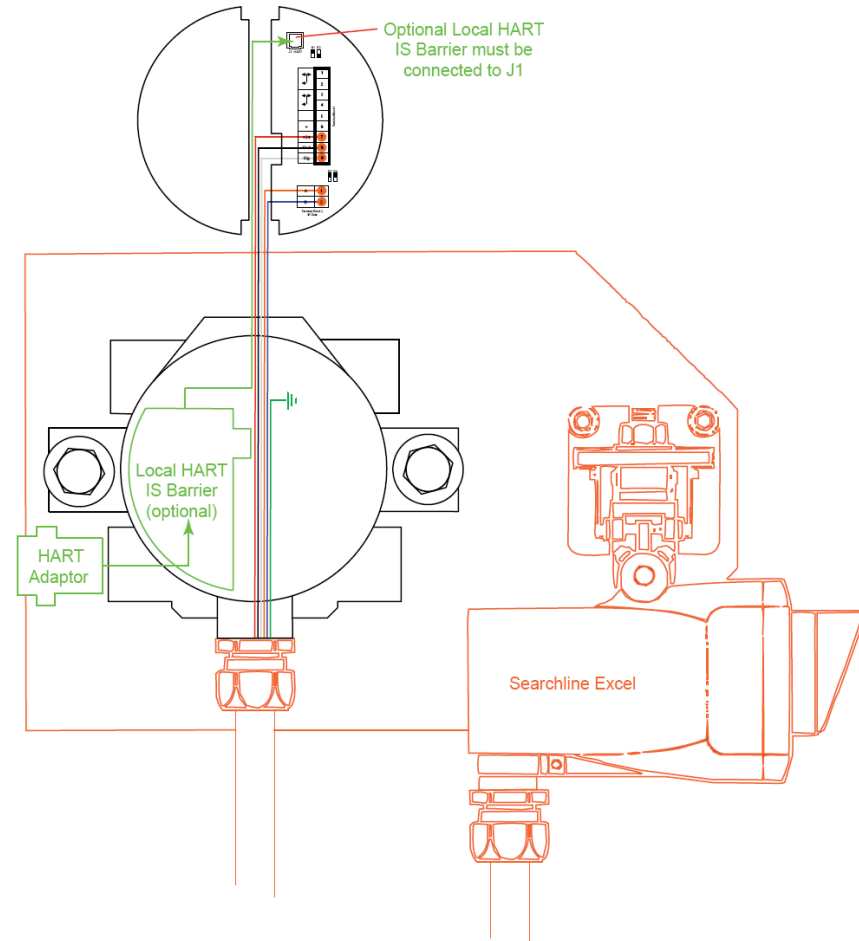

## Searchline Excel

# XNX Electrical Data

## IR version POD

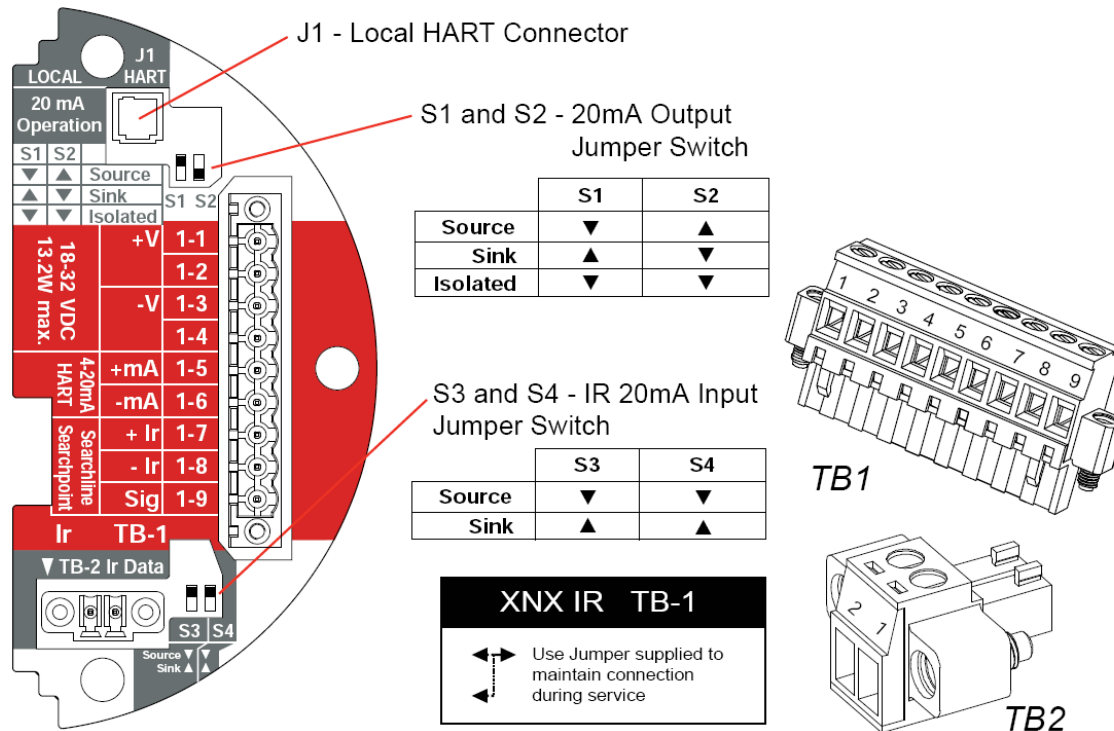

## POD options boards- relay

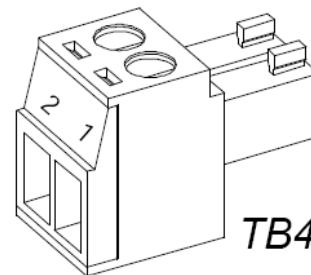
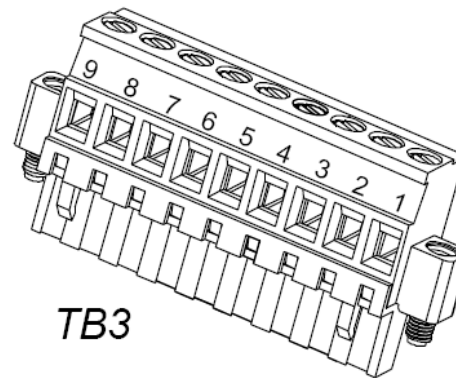
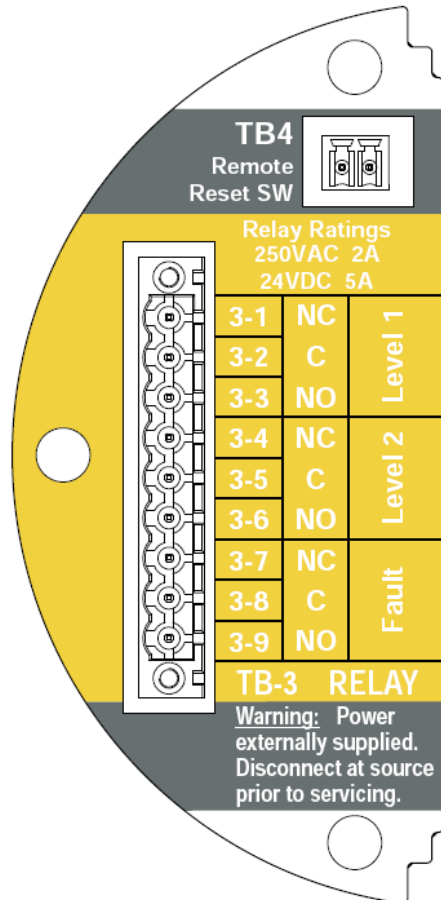

**TB3 Relay Connections**

**Warning:** Power externally supplied, disconnect at source prior to servicing

**Relay Contact Ratings:**  
230 VAC 5 amps  
24 VDC 1 amp

	Relay
<b>TB3</b>	
1	NC
2	C
3	NO
4	NC
5	C
6	NO
7	NC
8	C
9	NO
<b>TB4</b>	
1	1
2	2

## POD options boards- Modbus®

Terminals 3-1 through 3-4 are provided to facilitate bus wiring; there is no internal connection to other XNX circuitry. Terminal 3-1 is connected internally to 3-2. Similarly, terminal 3-3 is connected to 3-4

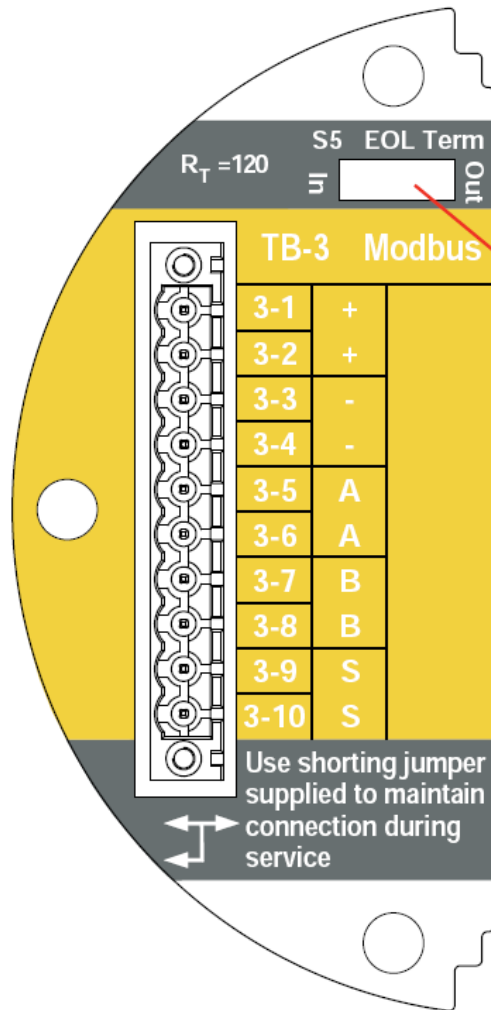

SW5 - Loop Termination

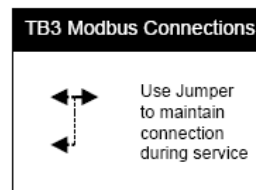
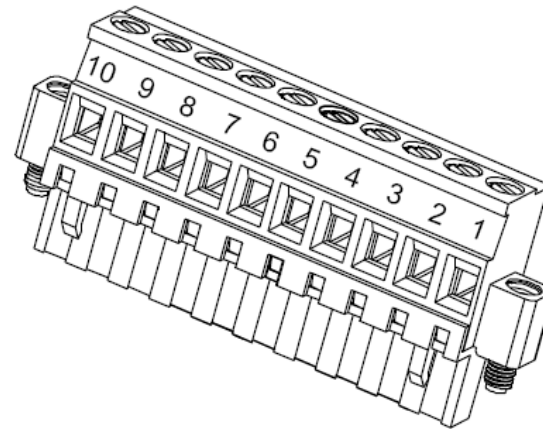

Modbus®	
TB3	
1	+
2	+
3	-
4	-
5	A
6	A
7	B
8	B
9	S
10	S

## POD options boards- Foundation Fieldbus™

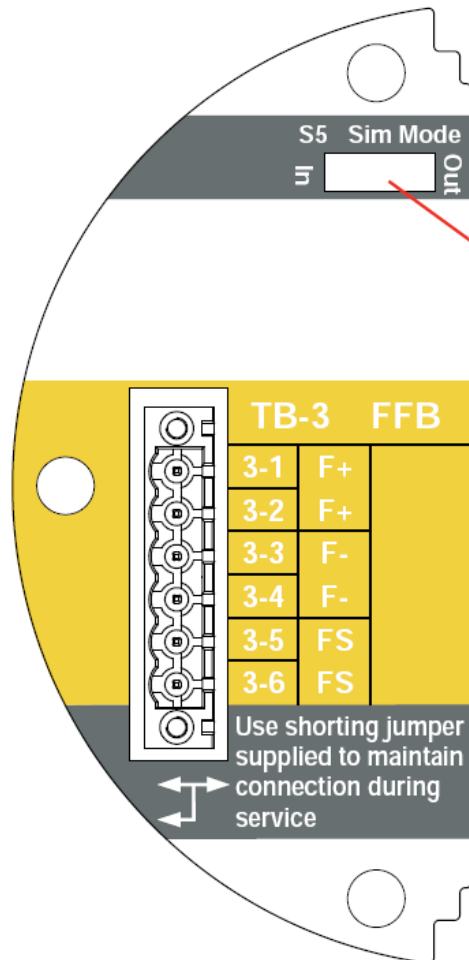

SW5 - Simulation Mode Switch

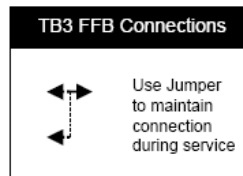
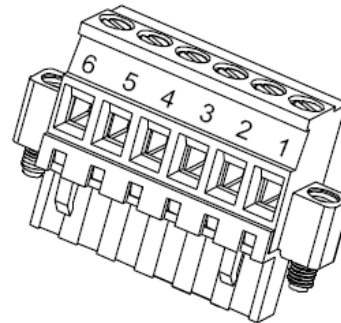

	FFB
TB3	
1	F+
2	F+
3	F-
4	F-
5	FS
6	FS

# XNX Display and user interface

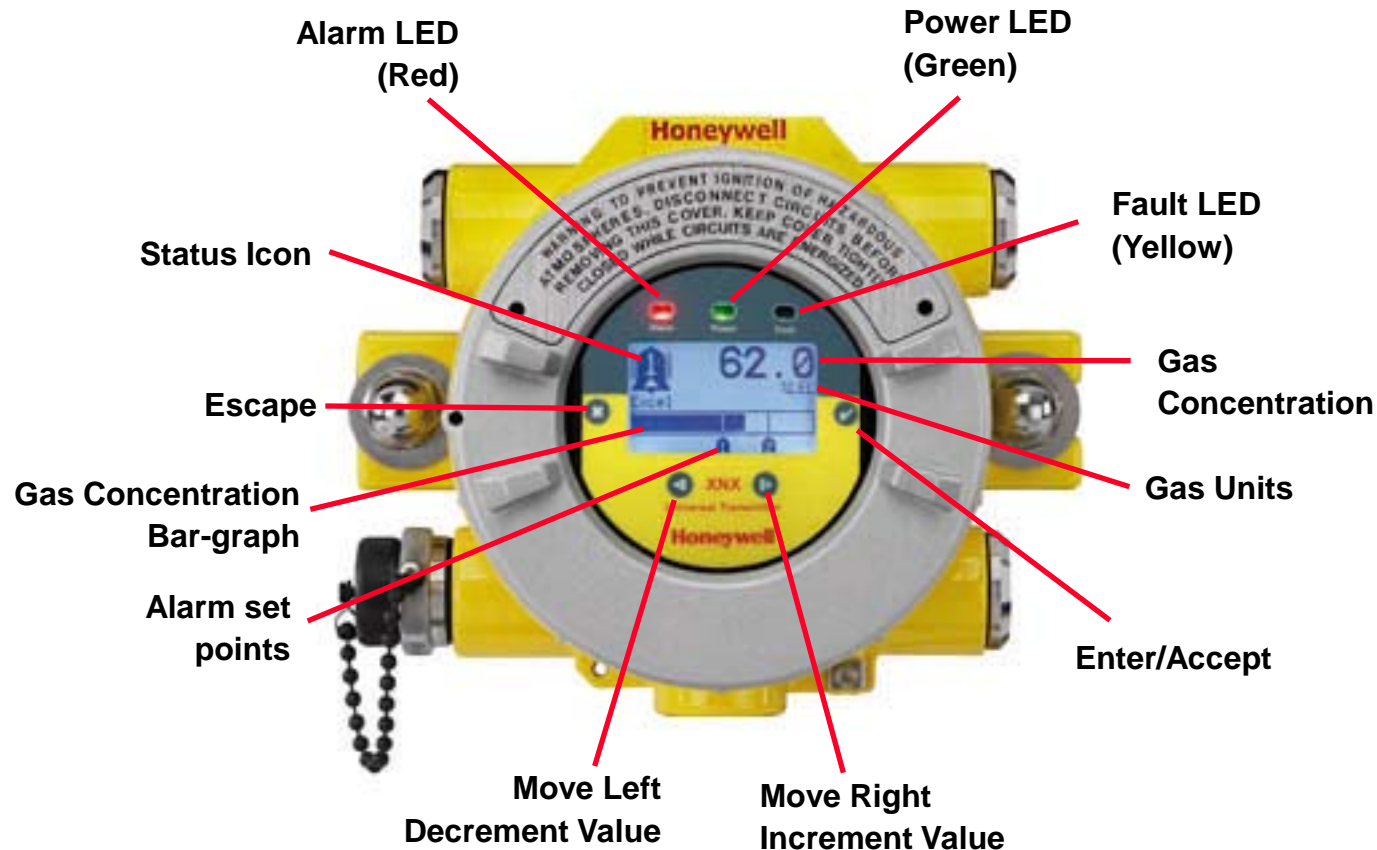

- Bright powder blue backlit LCD (auto dimming)
- Multilingual text, symbols and icons
- Simple Magnetic switch operation
- Optional local HART® handheld interface

# XNX General Operation

- The XNX uses magnetic switches to enable non intrusive operation.
- To activate a magnetic switch, hold the factory-supplied wand/screwdriver up to the glass window and slowly swipe the magnet directly over the shaded area.
- For best results when making a selection, hold the magnetic wand/screwdriver as illustrated opposite.

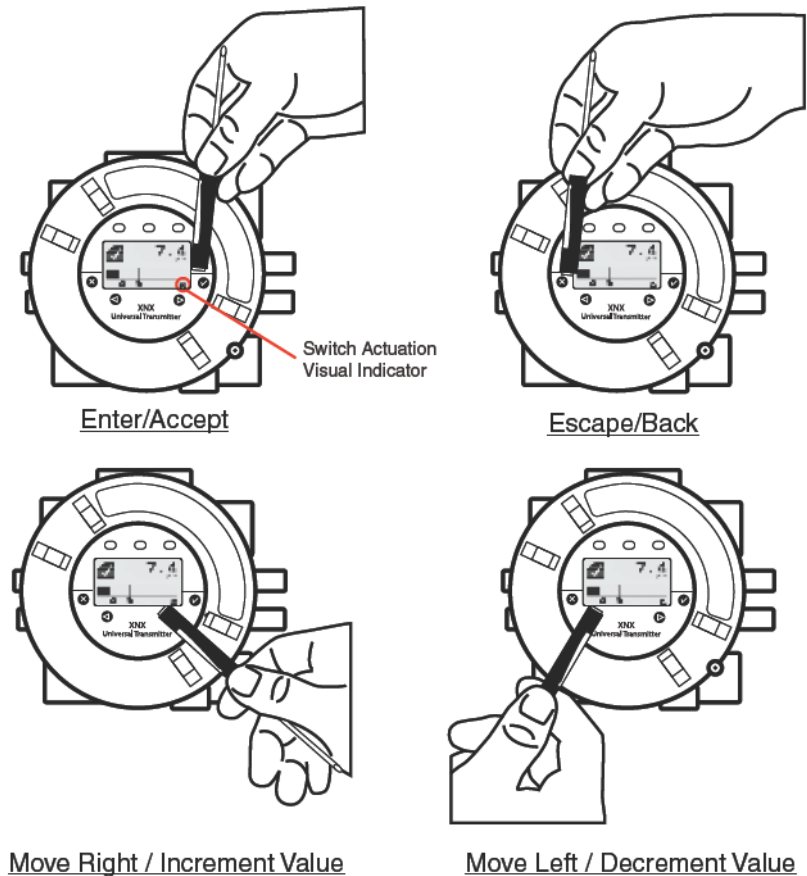

# XNX Passcodes

- There are two authorization levels that control access based upon the security level of the user.
  - Level 1 Routine Maintenance
  - Level 2 Technician and passcode
- The passcodes for both levels are set at “0000” from the factory, and must be reset after installation to control access.
- Once the passcode screen is displayed, the first passcode digit is highlighted.
  - Use the + or - switches to increment or decrement through the values.
  - Once the correct value is displayed for the first digit, ✓ accepts the value and moves to the next digit or x will move to the previous digit of the passcode.







- Repeat for each of the remaining digits in the passcode.
- If the passcode is not entered correctly, the Invalid passcode screen is displayed and the user is returned to the General Status screen.

# XNX Main Menu

- Once the correct passcode has been entered, XNX displays the Main Menu.
- The Main Menu has the following options:



Main Menu Screen

	<b>Information Menu</b>	Displays current settings for the XNX including optional Relays and Modbus®
	<b>Test Menu</b>	Provides access to tools and settings to allow simulation of gas events to test the system
	<b>Gas Calibration Menu</b>	The XNX interface to calibrate sensors attached directly to the XNX
	<b>Configure Menu</b>	Access to settings to configure the XNX and the devices connected to it to your environment

# XNX Menu Structure

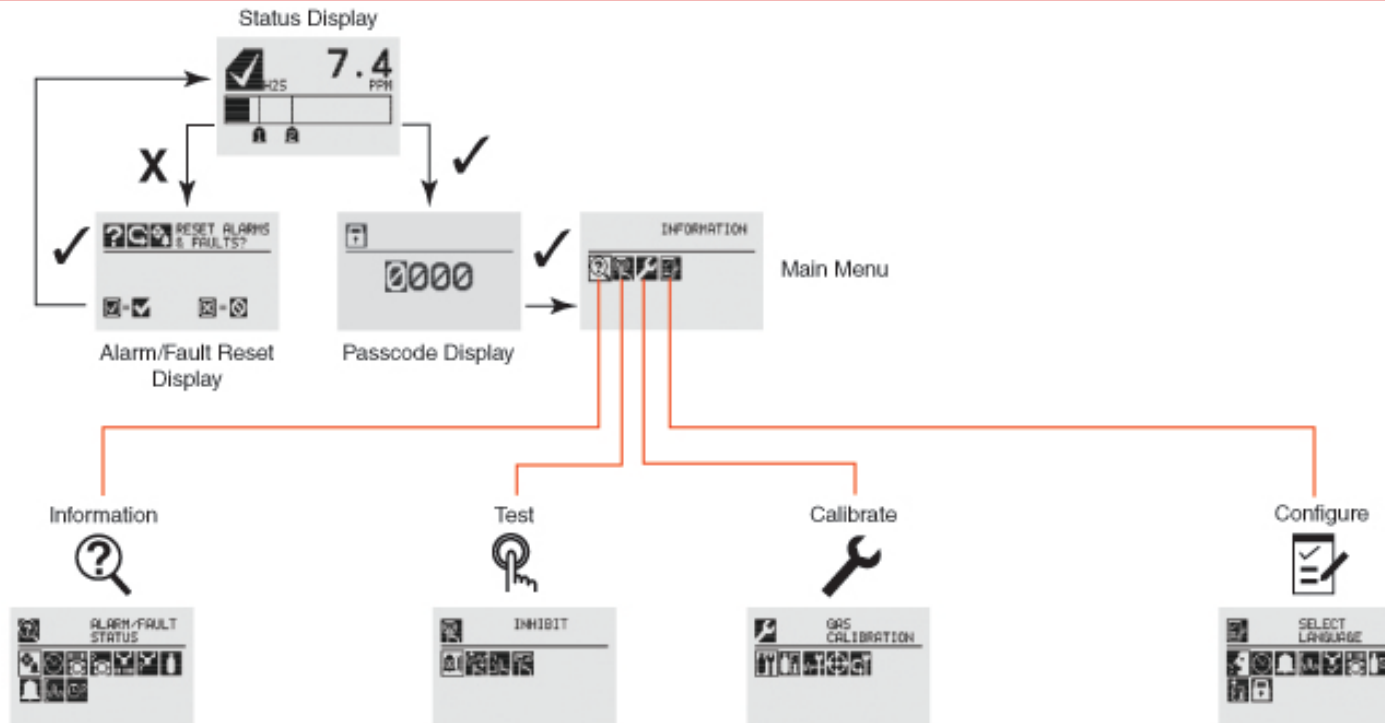

- Alarm/Fault Status
- Date & Time
- Transmitter Data
- Transmitter Status
- Sensor Data
- Sensor Status

- Gas Data
- Range/Alarm Settings
- mA Level Settings
- Fieldbus Settings<sup>2</sup>
- Relay Settings<sup>1</sup>
- Event History

- Inhibit
- Force mA Output
- Force Relay<sup>1</sup>
- Alarm/Fault Simulation













<sup>1</sup> Optional Relay Only  
<sup>2</sup> Optional Foundation Fieldbus or Modbus Only  
<sup>3</sup> Searchpoint Optima Only  
<sup>4</sup> Searchline Excel Only  
<sup>5</sup> Electrochemical Sensor Only  
<sup>6</sup> Pellistor Sensor Only

- Gas Calibration
- Bump Test
- Calibrate mA Output
- Align Excel<sup>4</sup>
- Soft Reset<sup>3, 4</sup>

- Select Language
- Set Date & Time
- Set mV Sensor Type<sup>6</sup>
- Set mA Sensor Type<sup>3, 4</sup>
- Gas Selection
- Range & Alarms
- mA Levels
- Accept New Sensor Type<sup>3, 6</sup>

- Beam Block Options<sup>4</sup>
- Path Length<sup>4</sup>
- Unit ID
- Calibration Interval
- Fieldbus Options<sup>2</sup>
- Relay Options<sup>1</sup>
- Set Units
- Configure Security

# Information Menu

Icon	Menu	Description
	Alarm/Fault Status	Displays an Alarm Reset screen allowing faults and alarms to be reset.
	Date/Time	Displays the date and time in the formats currently set on the XNX.
	Transmitter Data	Displays the ID, part number, serial number and revision level of the XNX firmware. Also used to accept new options added.
	Transmitter Status	Displays information about the XNX unit including temperature, 4-20mA output value and supply voltage.
	Sensor Data	Displays information about the XNX unit including sensor type and sensor software revision.
	Sensor Status	Displays the temperature and sensor life of the XNX EC or MPD sensor if used.
	Gas Data	Displays the detectable gas as configured for the attached sensor.
	Range/Alarm Settings	Displays the configured alarm information.
	mA Level Settings	Displays the mA output values for Inhibit, Warning and Overrange.
	Relay Settings	Displays the settings of the optional relays on the XNX.
	Fieldbus Settings	Displays the configuration of both HART® and Modbus.
	Event History	Lists all alarms or faults in chronological order beginning with the latest event.

# Test Menu













Icon	Menu	Description
	Inhibit	Switches the manual inhibit alarm output function on or off.
	Force mA Output	Forces a selected mA output to provide the means for testing operation of peripheral devices connected to the mA output.
	Force Relay	Forces the relay operation to provide the means for testing operation of peripheral devices connected to the relays.
	Alarm/Fault Simulation	Allows simulation of alarm, fault or warning operation.







# Calibrate Menu

Icon	Menu	Description
	Calibration	Allows the user to perform the zero and span calibration of the specific sensor attached to the XNX transmitter.
	Bump Test	Allows bump test of attached sensor and displays current and peak gas reading.
	Calibrate mA Output	Allows adjustment of the milliamp output to provide the correct signal at peripheral device(s).
	Soft Reset	Forces the relay operation to provide the means for testing operation of peripheral devices connected to the relays.
	Align Excel	Displays signal strength in the form of a bar graph for use when aligning the Searchline Excel Open Path Detector.

# Configure Menu

Icon	Menu	Description
	<b>Set Language</b>	Select a new display language from list of : English, Italian, Spanish, Mandarin, German, French, Russian or Portuguese
	<b>Set Date &amp; Time</b>	Set time and date, and date format.
	<b>Set mV sensor Type</b>	Set the mV sensor type from the list of available sensors shown.
	<b>Set mA Sensor Type</b>	Set the mA sensor type from the list of available sensors shown.
	<b>Gas Selection</b>	Set the target gas to be displayed for sensors capable of detecting multiple gases.
	<b>Range &amp; Alarms</b>	Adjust the full scale range of connected sensors with that capability. Set A1 and A2 alarm points and rising/falling action.
	<b>Latching / Non-Latching</b>	Configure A1, A2 and fault alarms to Latching or Non Latching action.
	<b>Set Units</b>	Provides the ability to set the units of measurement displayed on the XNX and transmitted via HART and Modbus.
	<b>mA Levels</b>	Sets the mA output levels for inhibit, warning, overrange and beam blocked and Low Signal for Optima Plus and Excel.
	<b>Calibration Interval</b>	Set a calibration interval warning. Set to '0' to disable warning.
	<b>Accept New Sensor</b>	Use to accept new EC cells or mV sensors to load default parameters into the XNX for calibration and sensor life. Also used when replacing an EC cell with another for a different target gas.

# Configure Menu (cont'd)

Icon	Menu	Description
	Beam Block Options	Allows the user to define the maximum period of time the Searchline Excel infrared beam can be blocked and the percentage of signal loss before generating a warning through the XNX.
	Path Length	Set the path length between transmitter and receiver for optimum operation of Searchline Excel open path detector
	Unit ID	Define a unique 18 character Unit ID for each XNX. This can be broadcast over any of the supported communication options.
	Relay Options	The optional XNX Alarm relays can be set to Energized or De-energized. The factory default setting is de-energized.
	Fieldbus Options	Allows configuration of the HART® address or the optional Modbus® fieldbus address and baud rate.
	Security	Used to set or reset level 1 and level 2 passcodes that control access to the configuration menus of the XNX.

# XNX Default Configuration

- **XNX is supplied with the default configuration shown opposite.**
- **Other configurations are sensor type and output option dependent.**

<b>Display Language</b>		English
<b>Date Format</b>		mm/dd/yy
<b>Time Format</b>		HH:MM
<b>mA Sensor Type (w/IR Personality)</b>		Searchpoint Optima Plus
<b>mV Sensor Type (w/mV personality)</b>		MPD-IC1 (%Vol)
<b>Alarm Levels</b>		Sensor Cartridge Dependent
<b>Latching/Non-Latching Alarms</b>		Alarm: Latching Fault: Non-Latching
<b>Display Units</b>		PPM, %VOL or %LEL (dependent on personality and sensor choice)
<b>4-20 mA Levels</b>		Inhibit: 2.0 mA Warning: 3.0 mA Overrange: 21.0 mA
<b>Calibration Interval</b>		180 Days (HA recommends 30 day interval)
<b>Unit ID</b>		XNX #nnnnnnnn
<b>Relay Settings</b>		Alarm Normally De-Energized
<b>Fieldbus Settings</b>		
	<b>HART®</b>	Address: 0 Mode: Point-To-Point
	<b>Modbus® (if installed)</b>	Address: 5 Baud Rate: 19200
<b>Level 1 Password Access</b>		0000
<b>Level 2 Password Access</b>		0000
<b>Easy Reset Enabled</b>		Yes

# XNX Commissioning/First Time Start Up

After mounting and wiring the XNX and associated sensor, the installation should be visually and electrically tested as below:

1. Check that the transmitter is wired correctly according to this manual and the associated control equipment manual.
2. If equipped, unscrew the weatherproof cover, loosen the sensor retainer locking screw and unscrew the retainer.
3. For EC sensors, plug in the sensor cartridge taking care to align the sensor pins with the connector holes in the PCB. (For toxic sensors, remove the shorting clip from the bottom of the sensor prior to installation. For O2 sensor, there is no shorting clip provided).
4. Refit the sensor retainer, tighten the locking screw and refit the weatherproof cover.

Note: Before replacing the cover on the transmitter housing, coat the threads with anti-seize compound to prevent corrosion build-up. Also inspect the cover o-ring for cracking or any other defect that might compromise the integrity of the seal. If it is damaged, replace with the o-ring supplied in the accessory kit.

5. Apply power to the XNX which will in turn provide power to the detector.

# XNX Commissioning/First Time Start Up

6. The detector output will be forced to 1mA (default fault/inhibit).
7. The XNX display will enter a start up routine displaying the initialization screen, then the transmitter loads its operating system, data from the sensor and checks if it is the same type transmitter and sensor software version numbers, gas type, the detection range and span calibration gas level, estimated time to next calibration due, and self test result. The boot-up procedure takes approximately 45 seconds.
8. In the final stages of boot-up, warnings and faults may be observed until the user performs the proper configuration, calibration, and reset activities.
9. Once the General Status screen appears, the transmitter and detector are in normal 'monitoring' mode.
10. Calibration of sensors attached to the XNX is mandatory before the detector can be used for gas monitoring.
11. For EC and mV personalities, be sure to perform 'Accept New Sensor Type' before calibrating the sensor.

**When powering the XNX fitted to the Searchline Excel, the following procedure must be followed to assure proper installation.**

- 1. When the XNX completes boot-up, perform a Soft Reset on the Excel from the Calibration Menu.**
- 2. When the reset is complete, Set Date & Time.**
- 3. Set the Path Length for the application, then align the transmitter and receiver with Align Excel.**
- 4. Once the alignment is complete, a Zero Calibration must be performed on the Excel to complete the commissioning process.**
- 5. Reset any faults displayed on the XNX display. The XNX and Excel are now ready to monitor.**

- **Each of the sensor technologies supported by the XNX Universal Transmitter uses unique calibration procedures.**
- **The description provided illustrates the XNX interface to the sensor device and does not replace the procedures found in each device operating manual.**
- **The Gas Calibration menu is used for Zero and Span calibration as well as functional gas testing (bump test). The Gas Calibration menu is accessed from the main menu screen.**

# XNX General Zero Calibration

- 1. If using compressed gas cylinder, push the calibration gas flow housing onto the bottom of the sensor and apply the gas.**
- 2. Access the calibration mode.**
- 3. Apply the zero gas. As the sensor detects the gas and the concentration is increasing, the values displayed will reflect the changing concentration. When the concentration values are stable select ✓ to allow the XNX to calculate the zero adjustment.**
- 4. Selecting X will return to the Gas Calibration menu.**
- 5. If the Zero Calibration is successful, the XNX Universal Transmitter will display the Zero Passed screen.**

# XNX General Span Calibration

If a Span Calibration is not required, select X to skip the Span Calibration and return to the Calibration menu.

1. When the Zero Calibration is complete, the Span Concentration screen appears to indicate the concentration value of the gas used for calibration. If Span is skipped, the user is returned to the Gas Calibration Screen.
2. Indicate the concentration of the span gas to be used by selecting ✓ to choose the first digit and use the + & - switches to increment or decrement the values; ✓ accepts the new value and moves to the next digit. Continue until all 3 digits have been selected.
3. Apply the span gas. As the sensor detects the gas and the concentration is increasing, the values displayed will reflect the changing concentration.
4. When the concentration values are stable select ✓ to perform the span. The Span Calibration process also determines whether the sensor is within the proper range to accurately detect the target gas.

# XNX General Span Calibration

5. **Selecting X will return to the Gas Calibration menu.**
6. **When the sensor has completed the calibration and the span algorithms have determined that it is within range, the Span Passed screen will appear.**
7. **If the calibration is not successful, the Span Failed screen will display.**
8. **Selecting ✓ will return to the Span Concentration screen to begin the span calibration again. X will exit Span Calibration and return to the Main Calibrate screen.**
9. **Once the Zero and Span calibrations are completed successfully, the XNX will exit the calibration procedure. Before returning to the Gas Calibration menu however, the user will be prompted to Exit and turn alarm and fault inhibit off, exit and leave the XNX in inhibit mode, or do not exit.**

# XNX EC Sensor Calibration

**Before initial calibration allow the detector to stabilize for 30 minutes after applying power.**

**When in zero and span calibration mode the current output from the detector is inhibited (default 2mA) to avoid false alarms.**

**It is recommended for most sticky gases (i.e.: HCl, Cl<sub>2</sub>) the tubing should be PTFE with short pieces of rubber tube to make the final connection due to the inflexibility of PTFE.**

**To calibrate the detector, use an appropriate span gas cylinder, flow regulator set to 300-375mL/min, tubing, magnet and calibration gas flow housing.**

**A compressed gas cylinder (20.9%Vol oxygen) should be used to perform the zero calibration if the area where the detector is located contains any residual amount of the target gas. If no residual gas is present then the background air can be used to perform the zero calibration.**

**The Oxygen sensor does not require a zeroing procedure. Background air (20.9%Vol oxygen) can be used to span the oxygen sensor in place of a compressed air cylinder (20.9%Vol oxygen).**

## **Zero and Span Calibration notes for XNX EC Hydrogen Sulphide (H<sub>2</sub>S) Sensors:**

**Hydrogen Sulphide sensors can be affected by extreme humidity changes. A sudden increase in ambient humidity can result in a short term positive drift in the instrument's reading. A sudden decrease in ambient humidity can result in a short term negative drift in the instrument's reading. These are most likely to be noticed during calibration with dry or cylinder gas.**

**To zero the sensor, use a compressed gas cylinder of 20.9%Vol oxygen (not Nitrogen). Do not use background air. If a span calibration is to be performed, the span calibration gas should be applied to the sensor immediately after the zeroing procedure. Do not allow the sensor to return to ambient air conditions.**

It is recommended that the detector is tested frequently to ensure the system is operating properly. The weatherproof cover has a spigot for attaching tubing from a gas cylinder. This may be used for a simple functional (or bump) test of the sensor. However, this method may not be suitable for all gas types and/or applications due to environmental conditions. It is the responsibility of the user to ensure suitability of this method for each application.

1. **Select Bump Test from the Calibrate Menu.**
2. **When bump gas is applied to the sensor, the bump test screen displays the current reading of the sensor and the peak reading that has occurred during the bump test.**
3. **If the difference between reading and applied gas concentration is outside the acceptable limits for the application follow the procedures for zeroing and calibrating the detector**
4. **If reading is still inaccurate replace the sensor.**
5. **Once the Bump Test is completed successfully, the XNX will exit the Bump Test procedure. Before returning to the Gas Calibration menu however, the user will be prompted to Exit and turn alarm and fault inhibit off, Exit and leave the XNX in inhibit mode, or do not exit.**

## MPD Sensor Cartridge Replacement

1. Check that the label on the new sensor is the correct gas type.
2. Remove power from the transmitter.
3. Unscrew the weatherproof cover (if equipped), loosen the retainer locking screw and unscrew the sensor retainer.
4. Remove the old sensor by pulling without twisting.
5. Slide the replacement cell into the MPD body taking care to align the tab with the alignment slot, then press the cell firmly to seat it into the body.
6. Refit the sensor retainer, tighten the locking screw and refit the weatherproof cover (if equipped).
7. Re-calibrate the detector

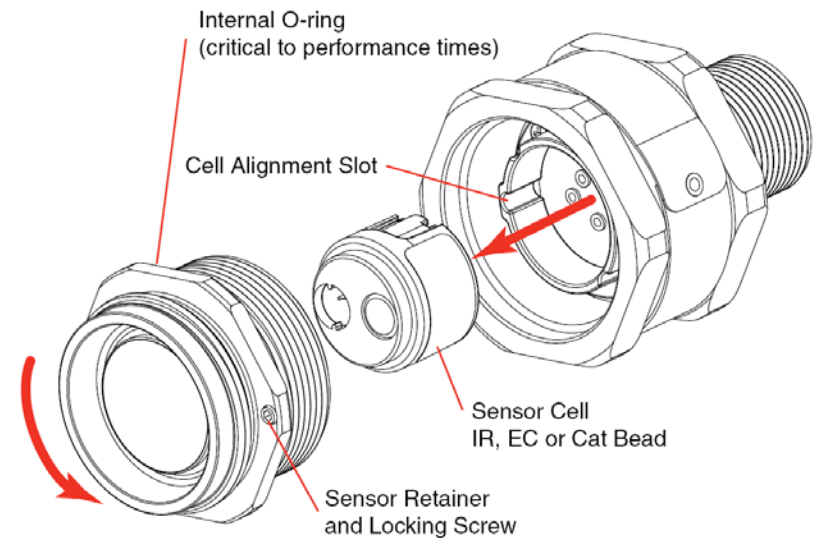

# XNX Service and Maintenance

## XNX EC Sensor Cartridge Replacement

The serviceable EC sensor allows replacement of the cell inside the sensor. The sensor cell can be replaced with cell of the same type or changed to detect a different target gas. Note: When replacing Oxygen (O<sub>2</sub>) sensor cells, the initial warm-up time is between 10 and 15 minutes. This warm-up is required only after sensor cell replacement.

To replace the cell follow the procedure below.

1. Unscrew the weatherproof cover, loosen the sensor retainer locking screw and unscrew the sensor retainer.
2. Remove the old sensor by pulling without twisting.
3. Unscrew the sensor cap.
4. Remove the old cell by pulling without twisting.
5. Ensure the new cell is the same type as the old cell.
6. Plug the new cell into the sensor, taking care to align the sensor pins with the connector holes in the PCB.
7. Refit the sensor retainer, tighten the locking screw and refit the weatherproof cover.

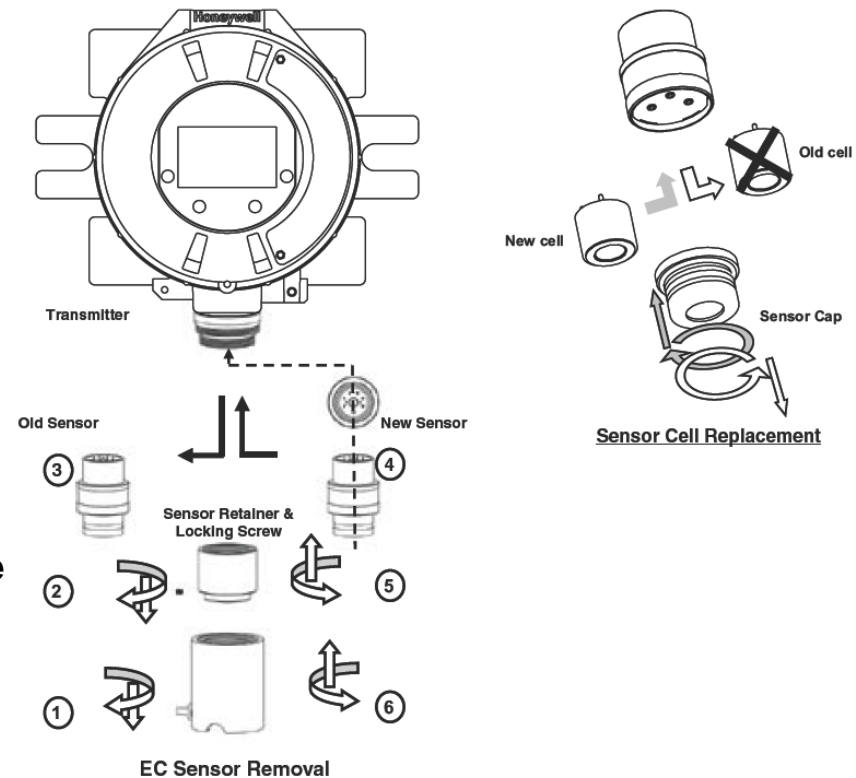

8. **Sensor warm-up will begin and the XNX display will alternate between two screens Fault 151 and 'WARM'.**
9. **Note: If a different gas type cell is fitted, a message such as 'G:TBV:O2'. 'TBV' is also displayed.**
10. **The 'O2' will reflect the gas type of the new cell.**
11. **Select the 'Accept New Sensor Type' in the 'Configure Menu'.**
12. **When changing the target gas by inserting a new sensor, cartridge the XNX will prompt the user for a confirmation of the change before adjusting to the properties of the new sensor.**
13. **The display of the XNX will show the old sensor cartridge type as well as the new sensor cartridge type and requires the user to approve ✓ or reject X the new sensor cartridge.**
14. **Re-Calibrate the detector.**

# XNX Warning Codes

- XNX has a comprehensive list of Warning and Fault codes. Refer to the manual for addition information codes

Warning					
Number	Description		Event History Information	Condition	Recovery
W001	XNX 24 VDC Supply Bad			DC power supply at/below 16VDC or at/above 33VDC for XNX	Check PSU start voltage, check cable loop impedance, check terminal connections.
	EC				
	mV				
	IR				
W002	XNX Temperature Warning			XNX internal temperature exceeding stated limits	Check unit location for external heat source, fit sunshade or other protection, possibly re-site unit and/or consider sampling system
	EC	All personalities			
	mV				
	IR				
W003	Simulated Warning			Simulated warning from Alarm/Fault Simulation	See <a href="#">Alarm/Fault Simulation</a> . After simulation, reset all faults and alarms before exiting 'Alarm/Fault Simulation' - the front panel LED and relays will remain in fault/warning/alarm mode until reset.
	EC	All personalities	None		
	mV				
	IR				
W005	Sensor Temperature Warning			Sensor internal temperature exceeding limits	Check sensor location for external heat source, fit sunshade or other protection, possibly re-site sensor or consider sampling system
	EC	Sensor Cartridge Temperature	Cartridge Temperature		
	mV	N/A	N/A		
	IR	Excel/Optima Temperature	Sensor Fault Code - See Detector Manual		
W006	Sensor Negative Drift			Sensor connected to unit has an internal 'zero' shift exceeding its stated limits	Check sensor location for external interference, check sensor for operation and re-zero where appropriate
	EC		None		
	mV				
	IR				
W007	Calibration Needed Soon			Calibration interval time exceeded	Recalibrate or disable the Calibration Interval - See <a href="#">Calibration Interval</a> . <b>NOTE:</b> Although the fault LED will be lit on the XNX front panel, the fault relay WILL NOT BE ACTIVATED.
	EC	All Personalities	None		
	mV				
	IR				

# XNX Warning Codes

Warning					
Number	Description		Event History Information	Condition	Recovery
W009	Sensor 24 VDC Supply Bad			IR sensor connected has DC at or below lower limit	Correct PSU voltage, verify cable loop impedance, verify terminal connections.
	EC	N/A	N/A		
	mV				
	IR	IR Sensor Voltage - Excel/Optima	IR Sensor Fault Code		
W010	Obscured Beam or Optics			Optical sensor connected is losing/has lost IR signals	Check sensor location for external interference (obstruction in IR path), check sensor for 'dirty' windows. Check Excel alignment; transmitter operation
	EC	N/A	N/A		
	mV				
	IR	Excel/Optima	IR Sensor Fault Code		
W011	Lamp Output			Optima+ sensor has an internal lamp issue	Remove sensor and return to Honeywell for repair
	EC	N/A	N/A		
	mV				
	IR	Optima	IR Sensor Fault Code		
W012	Excessive Float			Sensor connected to unit has an internal baseline shift exceeding its stated limits	Check sensor location for external interference, check sensor for operation and re-zero where appropriate
	EC	N/A	N/A		
	mV				
	IR	Excel/Optima	IR Sensor Fault Code		
W013	Sensor Loop Warning			Optical sensor connected is losing/has lost mA output signals	Check supply voltage is stable, check cable loop impedance, check terminal connections. Perform soft reset on Excel (see <a href="#">Soft Reset</a> )
	EC	N/A	N/A		
	mV				
	IR	Excel/Optima	IR Sensor Fault Code		
W014	Real Time Clock Error			Excel sensor has an internal real time clock error	If repeated, contact HA Service
	EC	N/A	N/A		
	mV				
	IR	Excel	IR Sensor Fault Code		
W015	Excel Software Diagnostic			Excel sensor has an internal software error	Re-cycle Excel power and confirm 'fault cleared', if not remove and return to Honeywell for repair.
	EC	N/A	N/A		
	mV				
	IR	Excel	IR Sensor Fault Code		

# XNX Warning Codes

Warning					
Number	Description		Event History Information	Condition	Recovery
W016	Installation Not Completed			Excel sensor has not completed a 'full' installation procedure	Check Excel alignment and confirm operating distance, rerun 'installation procedure'
	EC	N/A	N/A		
	mV				
	IR	Excel	IR Sensor Fault Code		
W018	General Diagnostic				
	EC		See Data Field In Event List For Information		
	mV	All Personalities			
IR					
W019	Internal Power Supply Defect			5V power supply failure in Excel receiver	Remove and return to Honeywell for repair.
	EC	N/A	N/A		
	mV				
	IR	Excel	IR Sensor Fault Code		
W020	Forced mA Timeout			XNX left in force mA mode too long	Exit Force mA mode. See <a href="#">Force mA Output</a> .
	EC		15min		
	mV	All Personalities			
	IR				
W021	Force Relay Timeout			XNX in force relay mode too long	Exit Force Relay mode. See <a href="#">Force Relays</a> .
	EC		15min		
	mV	All Personalities			
	IR				
W022	mV Sensor Calibration Needed			The mV sensor is different than current configuration; a change in target gas; change in sensor type. Calibrate before use.	After adjusting configuration, reset alarms and faults.
	EC	N/A	N/A		
	mV	mV Personality Board	None		
	IR	N/A	N/A		

# XNX Fault Codes

Fault					
Number	Description		Contents Of Data Field	Condition	Recovery
F101	Sensor Abnormal Reboot		Diagnostic Data	Sensor connected has restarted	If repeated, check supply voltage, check cable loop impedance, check terminal connections.
	EC	Cartridge			
	mV	PCB Personality			
	IR	Sensor	IR Sensor Fault Code		
F103	XNX Temperature Error		Temperature Celsius	The temperature of the XNX is out of range -30 °c to +83 °c	Check XNX location for external heat source, shade, possibly re-site XNX. See <a href="#">Transmitter Status</a> .
	EC	All Personalities			
	mV				
	IR				
F104	XNX 24 VDC Supply Bad		DC Voltage	XNX DC supply at/below 15VDC or at/above 34VDC	Correct psu voltage, verify cable loop impedance, verify terminal connections.
	EC	All Personalities			
	mV				
	IR				
F105	XNX Internal Power Supply Diagnostic		Voltage	POD power supply failure	Check <a href="#">Transmitter Status</a> . Contact HA Service
	EC	All Personalities			
	mV				
	IR				
F106	XNX Real Time Clock Failure		Diagnostic Data		Reset clock, see <a href="#">Set Date &amp; Time</a> .
	EC	All Personalities			
	mV				
	IR				
F107	XNX Internal Failure (RAM, ROM, Switch, etc)		Diagnostic Data	Corrupt program, internal RAM failure or microprocessor failure.	Contact HA Service
	EC	All Personalities			
	mV				
	IR				

# XNX Fault Codes

Fault					
Number	Description		Contents Of Data Field	Condition	Recovery
F108	XNX mA Output Loop failure		Milliamp Error	Digital diagnostic has detected an analog output problem	Check control circuit, check supply voltage is stable, check cable loop impedance, check terminal connections.
	EC	All Personalities			
	mV				
	IR				
F109	Simulated Fault		None	XNX has been set into 'simulation'	Exit simulation
	EC	All Personalities			
	mV				
	IR				
F110	Sensor SW Mismatch		Detected Software Version	The XNX will not support Optima operating software below release 3.0	Contact HA Service
	EC	N/A			
	mV	N/A			
	IR	Searchpoint Optima Plus			
F111	Negative Drift		Raw Concentration Value Of Sensor	Sensor connected to XNX has a negative drift exceeding its stated limits	Check sensor location for external interference, check sensor for operation and re-zero where appropriate, replace sensor if required.
	EC	All Personalities			
	mV				
	IR				
F112	Sensor 24 VDC Supply Bad		N/A	IR sensor connected has DC at or below lower limit	Correct PSU voltage, verify cable loop impedance, verify terminal connections.
	EC	N/A			
	mV				
	IR				
F113	Internal 5V Power Supply Defect		N/A	Excel sensor has an internal 5 volt power supply fault	Remove and return to Honeywell for repair.
	EC	N/A			
	mV				
	IR				
F114	Optima Lamp Output		N/A	Optima+ sensor has an internal lamp issue	Remove sensor and return to Honeywell for repair
	EC	N/A			
	mV				
	IR				

# XNX Fault Codes

Fault						
Number	Description		Contents Of Data Field	Condition	Recovery	
F116	Sensor Internal Failure				Optical sensor connected has an internal software fault	Remove sensor and return to Honeywell for repair
	EC	N/A	N/A			
	mV					
	IR	Excel/Optima	IR Sensor Fault Code			
F117	Sensor Loop Failure				Optical sensor connected is losing/has lost mA output signals	Check supply voltage is stable, check cable loop impedance, check terminal connections.
	EC	N/A	N/A			
	mV					
	IR	Excel/Optima	IR Sensor Fault Code			
F118	Sensor Real Time Clock invalid				Excel sensor has an internal 'real time clock' issue	Reset 'date and time' in Excel, re-cycle Excel power and confirm 'date and time', if not retained remove and return to Honeywell for repair.
	EC	N/A	N/A			
	mV					
	IR	Excel	IR Sensor Fault Code			
F119	Cartridge Failed				Internal electrical failure	Check cartridge connections, check sensor operation, fit replacement cartridge, replace personality board.
	EC	EC Cartridge	Diagnostic Data			
	mV	mV Personality Board				
IR	IR Personality Board					
F120	No Cartridge				No communication from sensor	Check sensor connections, check sensor operation, fit replacement sensor, replace personality board.
	EC	No Sensor Communication	Diagnostic Data			
	mV	No mV Board Communication				
IR	No RS485 Communication					
F121	Wrong Cartridge				Gas parameters invalid	Contact HA Service.
	EC	EC Sensor Cartridge	0			
	mV	mV Personality Board				
IR	N/A					
F122	DSP Problem				Optical sensor connected is losing/has lost processing signals	Check sensor location for external interference (obstruction in IR path), remove and return sensor to Honeywell for repair..
	EC	N/A	N/A			
	mV					
	IR	Excel/Optima	IR Sensor Fault Code			

# XNX Fault Codes

Fault					
Number	Description		Contents Of Data Field	Condition	Recovery
F123	Sensor Temperature Error			Sensor connected to unit has an internal temperature exceeding its stated limits	Check sensor location for external heat source, fit sunshade or other protection, possibly re-site sensor and/or consider sampling system
	EC	EC Cartridge	Cartridge Temperature		
	mV	N/A	N/A		
	IR	Excel/Optima	IR Sensor Fault Code		
F125	Calibration Required			Sensor connected has exceeded maximum calibration interval	Re-calibrate the sensor
	EC	EC Cartridge	Diagnostic Data		
	mV	mV Personality Board			
	IR	N/A	N/A		
F126	Sample Path Obscured			Optima is losing/has lost IR signals	Check sensor location for external interference, check sensor for 'dirty' windows.
	EC	N/A	N/A		
	mV				
	IR	Optima	IR Sensor Fault Code		
F127	Beam Block			Excel is losing/has lost IR signals	Check sensor location for external interference (obstruction in IR path), check sensor for 'dirty' windows. Check unit alignment.
	EC	N/A	N/A		
	mV				
	IR	Excel	IR Sensor Fault Code		
F128	Sensor Installation Checklist of Complete			Excel sensor has not completed a 'full' installation procedure	Check Excel alignment and confirm operating distance, rerun 'installation procedure' and calibrate.
	EC	N/A	N/A		
	mV				
	IR	Excel	IR Sensor Fault Code		
F130	Option communication Failure			Internal option board not communicating with XNX.	Contact HA Service
	EC	All Personalities	Diagnostic Data		
	mV				
	IR				
F133	Low Optical Sample Signal			Excel is losing/has lost IR signals	Check sensor location for external interference (obstruction in IR path), check sensor for 'dirty' windows. Check unit alignment.
	EC	N/A	N/A		
	mV				
	IR	Excel	IR Sensor Fault Code		

# XNX Fault Codes

Fault					
Number	Description		Contents Of Data Field	Condition	Recovery
F141	End of Cell Life		Diagnostic Data	Installed sensor exceeded sensor life parameter	Fit replacement cartridge.
	EC	EC Cartridge			
	mV	mV Personality Board			
	IR	N/A			
F143	Stabilization Timeout		Diagnostic Data	Sensor exceeds normal warm-up time	Cycle power, contact HA Service if problem persists.
	EC	Unstable Sensor Output			
	mV				
	IR	Sensor Exceeded Expected Stabilization Time			
F145	Reflex Failure		Diagnostic Data	EC cell has reached end of life.	Fit replacement cell or cartridge.
	EC	EC Cartridge			
	mV	N/A			
	IR				
F146	General Optical Fault		N/A		Contact HA Service
	EC	N/A			
	mV				
	IR	Excel/Optima			
F148	Option Board Failure		Diagnostic Data	Internal option board hardware failure.	Contact HA Service
	EC	All Personalities			
	mV				
	IR				
F149	Internal Communication Failure (mA)		N/A	Internal 4-20 mA monitoring circuit communication failure.	Contact HA Service
	EC	All Personalities			
	mV				
	IR				
F150	mA Output Monitoring Fail		Actual measured mA output value	mA not producing expected levels.	Contact HA Service
	EC	All Personalities			
	mV				
	IR				

# XNX Fault Codes

Fault					
Number	Description		Contents Of Data Field	Condition	Recovery
F151	Sensor Module Type Changed			Sensor with different gas type installed or different sensor installed.	For EC: Perform <a href="#">Accept New Sensor</a> function, if problem persists contact HA Service mV/IR: Contact HA Service
	EC	EC Cartridge w/Different Gas Type	Diagnostic Data		
	mV	N/A	N/A		
	IR	Switching Between Excel and Optima	Diagnostic Data		
F152	Option Module Configuration Error			Invalid substitution of option boards.	Confirm option properly installed, reconfigure unit contact HA Service.
	EC	All Personalities	Diagnostic Data		
	mV				
	IR				
F153	Digital Communication Fail			Analog output of sensor is out of tolerance.	Contact HA Service.
	EC	N/A	N/A		
	mV				
	IR	Excel/Optima	Concentration Digital Value		
F154	mA Input Diagnostic Failure			Sensor not responding to diagnostic command	Contact HA Service.
	EC	N/A	N/A		
	mV				
	IR	Excel/Optima	Concentration Digital Value		
F155	Generic mA Sensor Type Error			Generic mA input below 3 mA.	Check mA input wiring and device, check positions of S3 and S4. Contact HA Service.
	EC	N/A	N/A		
	mV				
	IR	Generic mA Sensor Type Error	Measured mA Input		
F156	mV Current Control Fail			Sensor installed requires supply outside of limits.	Set correct mV type (see <a href="#">Set mV Sensor Type</a> ), verify wiring to mV sensor, replace sensor, replace personality. Contact HA Service
	EC	N/A	N/A		
	mV	Control Range Error			
	IR	N/A	N/A		
F157	Sensor Drift Fault			Background gas concentration present, sensor defective.	Perform zero calibration using zero air, replace sensor.
	EC	EC Sensor	Diagnostic Data		
	mV	mV Personality Board			
	IR	N/A	N/A		

# XNX Fault Codes

Fault					
Number	Description		Contents Of Data Field	Condition	Recovery
F158	Sensor/Personality Part Number Mismatch			Installed sensor hardware mismatches configuration.	Contact HA Service
	EC	All Personalities	XNX Part Number		
	mV				
	IR				
F159	Option Part Number Mismatch			Installed option hardware mismatches configuration.	Contact HA Service
	EC	All Personalities	XNX Part Number		
	mV				
	IR				
F160	Hardware Diagnostic Failure			Defective EC cartridge or mV personality board.	Replace EC cartridge, contact HA Service
	EC	EC Cartridge	Diagnostic Data		
	mV	mV Personality Board			
	IR	N/A	N/A		
F161	Fault Level mA Input Failure			IR mA input indicates sensor failure, less than 1 mA.	Check mA input wiring. Contact HA Service
	EC	N/A	N/A		
	mV				
	IR	Excel/Optima	Diagnostic Data		

# HART® Interface

- Every XNX gas detector can communicate using the HART® protocol. The HART® protocol is defined by the HART Communication Foundation at <http://www.hartcomm.org>. HART® is unique among fieldbuses in that the digital signal is superimposed on top of a traditional 4-20 mA current loop. This provides the solid reliability of analog signaling with the advanced diagnostic capability of a digital device.
- HART® devices are usually connected as point-to-point networks. Additionally, the analog output of the XNX can be disabled to facilitate construction of multidrop all-digital HART® networks.

## HART® Point to Point Mode

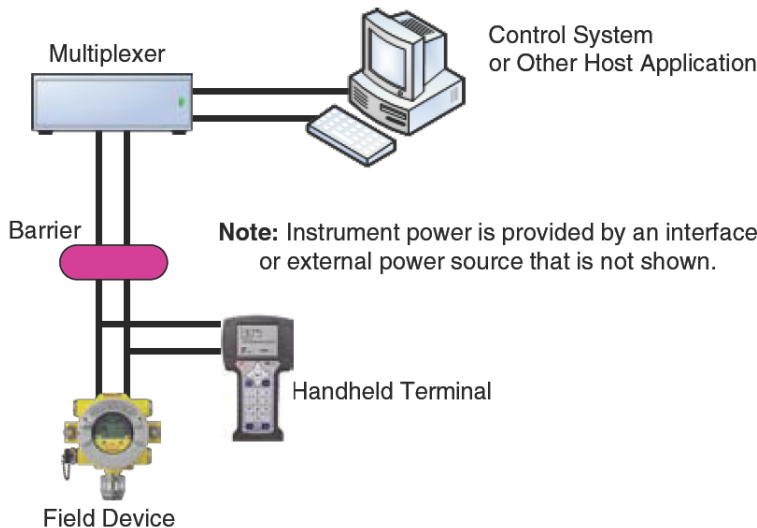

## HART® Multi Point Mode

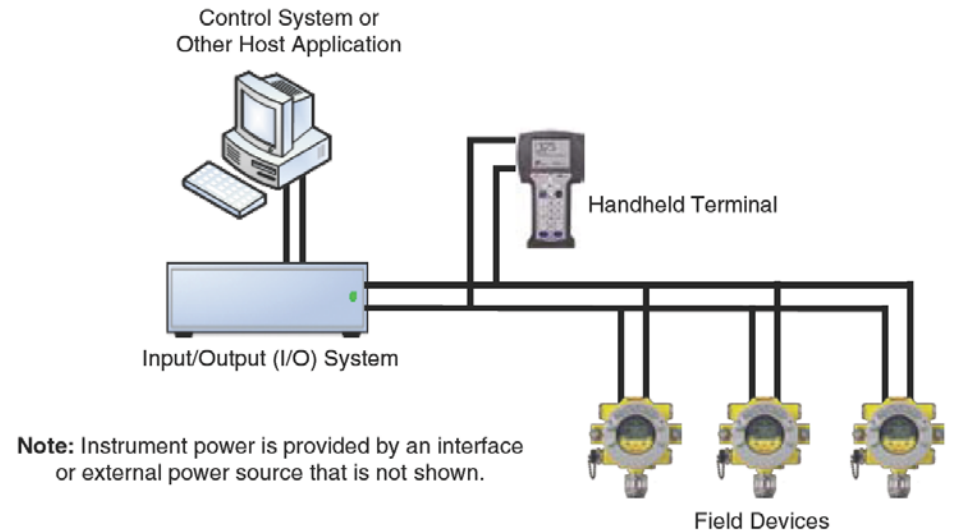

- If HART® is not needed the XNX may simply be used as a 4-20 mA transmitter. Since the XNX is a slave, the internal modem will remain silent if no master signal is present. Additionally the HART® signal is at too high of a frequency (1200 Hz) to interfere with analog control equipment.
- Another novel feature of HART® networks is that two masters may be present. The primary master is generally a distributed control system (DCS), programmable logic controller (PLC), or a personal computer (PC). The secondary master can be a handheld terminal. The XNX has been tested with the handheld Emerson 375 Field Communicator.
- The XNX device descriptor (DD) file provides HART® masters with data on the capabilities and features of the XNX gas detector. HART® terminals thus have a friendly, intuitive interface when connected to the XNX. At press time, the XNX DD file was not yet available on the HART® Foundation website. A copy of the file is included on the Documentation CD. This DD file may be installed in an Emerson 375 Field Communicator using the 375 Easy Update Programming Utility.
- During manufacturing, Honeywell configures the 8-digit HART® tag to the XNX serial number. This may be used to confirm correct wiring from the XNX to the control system. The HART® tag may be modified if desired. The fixed XNX serial number can also read over HART®.
- For convenience, the XNX presents the HART® signal on two interfaces. The 1200 Hz AC signal is capacitively coupled to the main 20 mA analog output. This may be monitored at the control system or at any point along the 20 mA loop. Additionally, the optional local HART® interface (P/N XNX-HIF) permits temporary connection of a HART® terminal to the XNX. This local HART® port is transformer-coupled to the main 20 mA output. This port is intrinsically safe and polarity insensitive.

- **The internal HART® modem functions as a high-impedance current source. Thus transferring the HART® signal requires a certain minimum loop resistance between the slave and a low-impedance power supply.**
- **Normally, this resistance is supplied by the control system and so need not be explicitly added. However, special treatment is needed when the mA output is not used and the local HART® interface is needed (an installer might choose to communicate using relays, Modbus, or Foundation Fieldbus instead.) In this case the supplied 510 Ohm resistor must be fitted to create an ‘artificial’ mA loop. The resistor should be connected between TB-1 terminal 1-3 and terminal 1-6. Additionally, S1 and S2 should be placed in ‘source’ configuration. This is shown in the following wiring schematic.**
- **The digital HART® interface provides all of the capabilities of the local user interface. The XNX has been designed to use the portable Emerson 375 Field Communicator and with DevCom2000 software for Microsoft Windows® and Emerson AMS Intelligent Device Manager. Using HART®, a service person can display information, test, calibrate, and configure.**

# HART® Sink, Source and Isolated Wiring

XXN Multidrop HART Network Wiring - XXN Sink

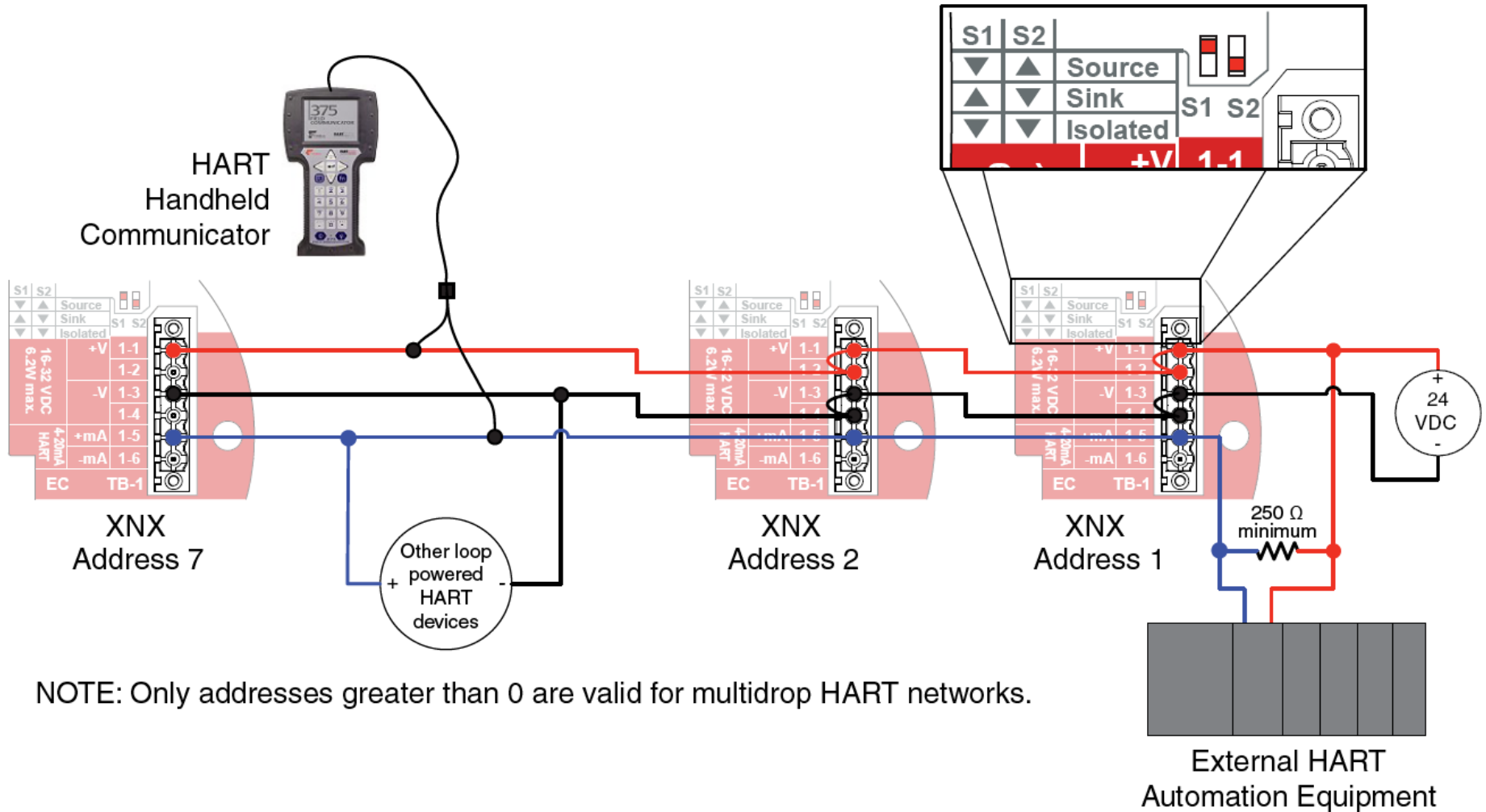

NOTE: Only addresses greater than 0 are valid for multidrop HART networks.

# HART® Sink, Source and Isolated Wiring

XXN Multidrop HART Network Wiring - XXN source

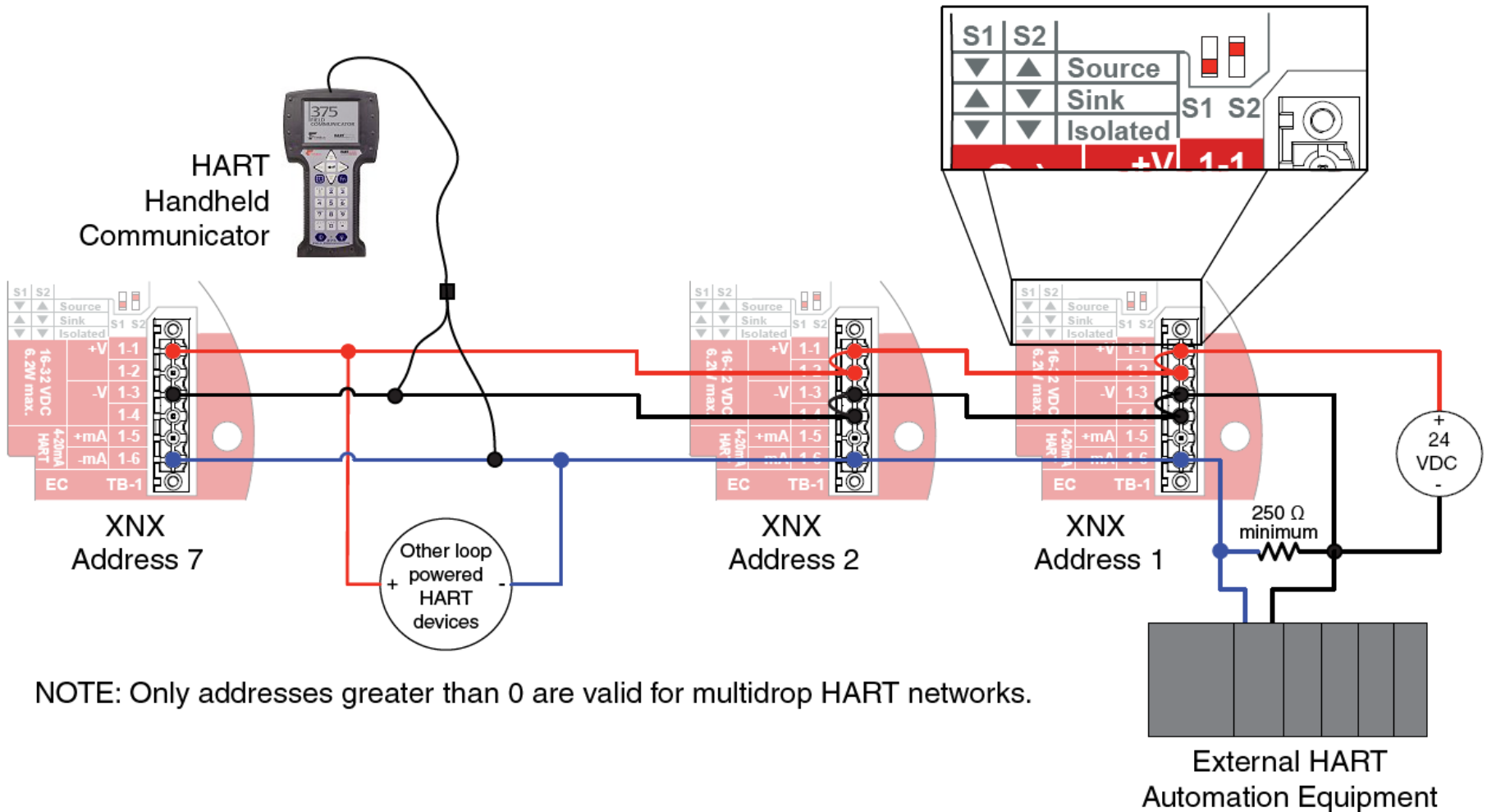

NOTE: Only addresses greater than 0 are valid for multidrop HART networks.

# HART® Sink, Source and Isolated Wiring

XNX Multidrop HART Network Wiring - XNX isolated

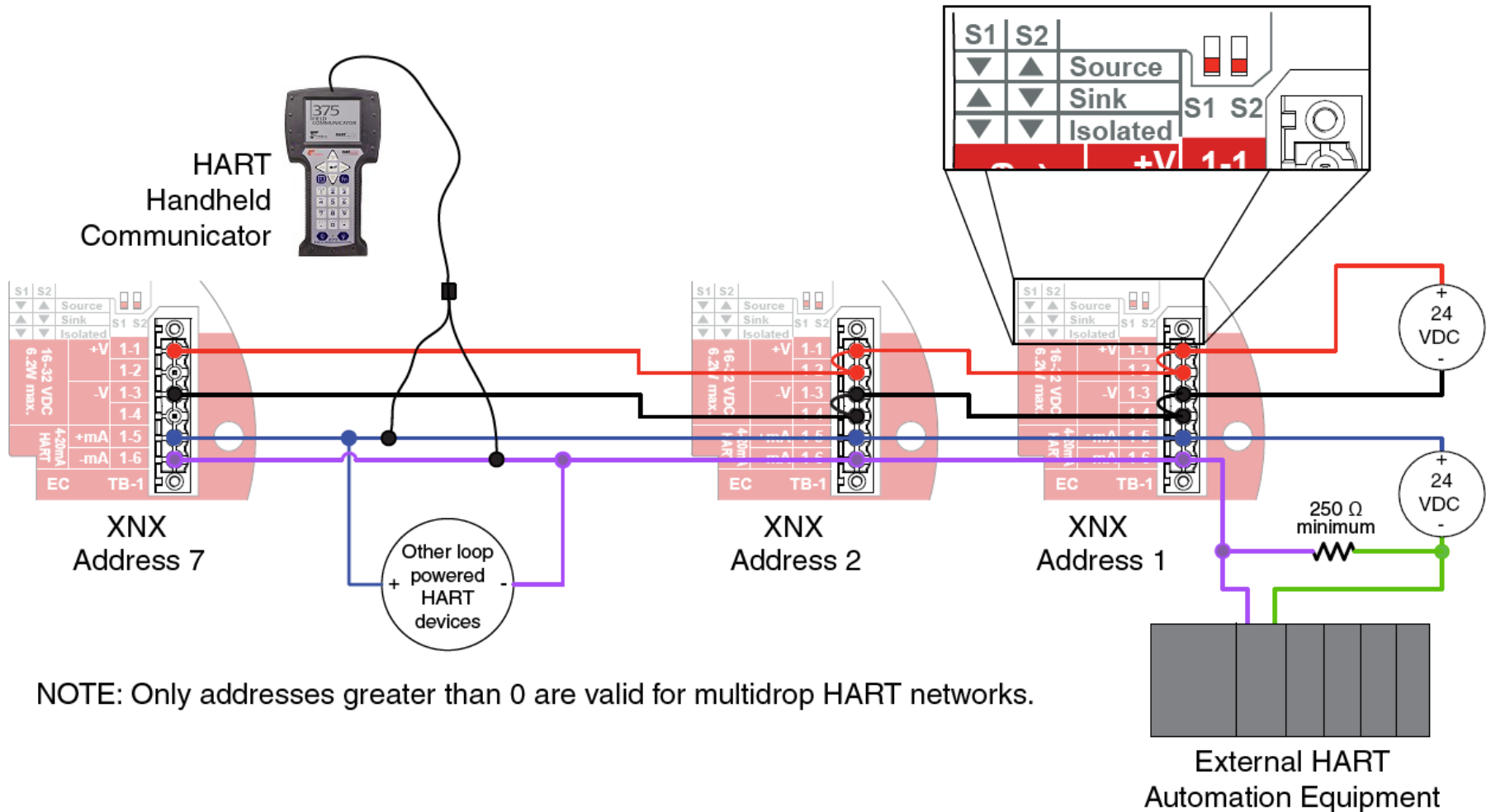

# DevComm PC-Based HART® Interface

- The XNX HART® interface facilitates remote access to all features of the local user interface including displaying status, testing, calibrating and configuring. A device descriptor (DD) file is available to adapt standard tools for use with the XNX. The screens below show some of the features of these two interfaces for the XNX.

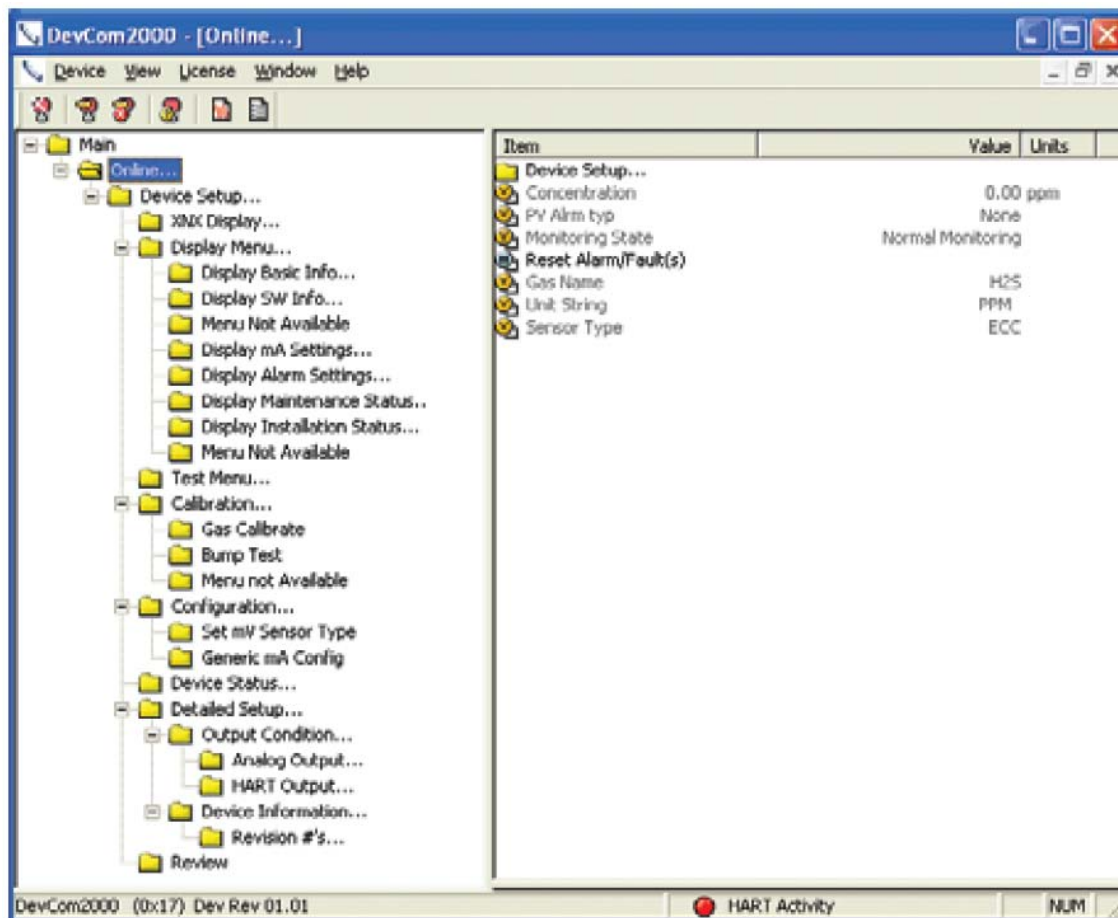

# HART® Configuration Summary

- It is simple to extract all of the HART® status information from the XNX as a PDF or text file. This includes voltages, signal strengths and configuration settings. An example summary is shown below.

```
DevCom2000, Rev 3.1, Device Configuration File - C:\Documents and
Settings\2317500\Desktop\TOWER_17_11234.txt
Tag: TOWER_17
Device ID: 11234
Date (yyyy-mm-dd): 2009-01-14
Time (hr-mm-ss): 01:38:45 PM
Notes:
```

```
Label, Value, Units
Conc Unit, ppm
Concentration, 0.00, ppm
Conc Current, 0.000000
AO Unit, mA
Info Max Range, 15.00, ppm
Info Min Range, 15.00, ppm
Sens Min Span, 15.00, %
PV Damp, 0.00, s
Sensor S/N, 18562
Signal Strength Unit,
Signal Strength, 0.00
Fault/Warn Number, --NA
Monitoring State, Normal Monitoring
AlmFaultLevel, Device Normal
Time Date Stamp, 1438999824, s
Time Date Format, mm/dd/yy hh:mm:ss
Sensor Life, 0, Days
Event Command, Newest Record
History Time Date, 1438997930
History Event Type, INFO
History Event Sub Type, 62
History Parameter, 0.000000
Event Index, 3
Power Supply Voltage, 24013, mVolt
Operating Voltage, 3300, mVolt
Sensor I/P Voltage, 0, mVolt
Sensor Voltage, 0, mVolt
```

```
XNX Temp, 32, degC
Sensor Temp, 24, degC
Measure as mg/m3, No
Rel Sig Strength, 0.000000, %
Inhibit Analogue, END LONG INHIBIT
Calib Cmd, Select
Align Excel, Select
Alarm Thresholds 1, 5.000000, ppm
Alarm Thresholds 2, 11.000000, ppm
Sensor Type, ECC
Password, 0
Password 1, 1
Password 2, 1
User, Level 2
Login Level, 0x02 Undefined
Inhibit Current, 2.000000, mA
Warning Current, 3.000000, mA
Overrange Current, 21.000000, mA
Bump, Stop Bump Test
Alarm Config, 0x0C Undefined
Relay State, Deenergize RELAY 1
Automatic Control, End Simulation
XNX ID, FRED
Gas Name, H2S
Gas Name, H2S
Unit String, PPM
Sensor Generic mA, Yes
Actual Index, 0
Info Index, 0
Access Reset, FALSE
Input Range, Reserved
Raw Conc, 0.116913
Modbus Addr, 5
```

# HART® Information Screens

- All of the information in the above Configuration Summary can be viewed live on various informational displays. For example, alarm settings are shown below.

The screenshot shows the DevCom2000 software interface. The title bar reads 'DevCom2000 - [Display Alarm Settings...]'. The menu bar includes 'Device', 'View', 'License', 'Window', and 'Help'. The toolbar contains icons for various functions. The left pane shows a tree view with 'Main' expanded to 'Online...' and 'Device Setup...'. Under 'Device Setup...', 'Display Menu...' is expanded, and 'Display Alarm Settings...' is selected. The right pane displays a table of alarm settings:

Item	Value	Units
<input checked="" type="checkbox"/> PV URV	15.000	ppm
<input checked="" type="checkbox"/> PV LRV	0.000	ppm
<input checked="" type="checkbox"/> Alarm Thresholds 1	5.000000	ppm
<input checked="" type="checkbox"/> Alarm Thresholds 2	11.000000	ppm
<input checked="" type="checkbox"/> Alarm Config	0x000c	
<input checked="" type="checkbox"/> Board Type	No Option	

The status bar at the bottom shows 'DevCom2000 (0x17) Dev Rev 01.01', a red 'HART Activity' indicator, and 'NL'.

# HART® Event History

- The XNX maintains a record of all significant events. All alarms, all warnings and all faults are recorded. Additionally, over 60 types of informational events are defined to record important transactions such as recalibrations or configuration changes. Every event has a timestamp and one thousand records are maintained.

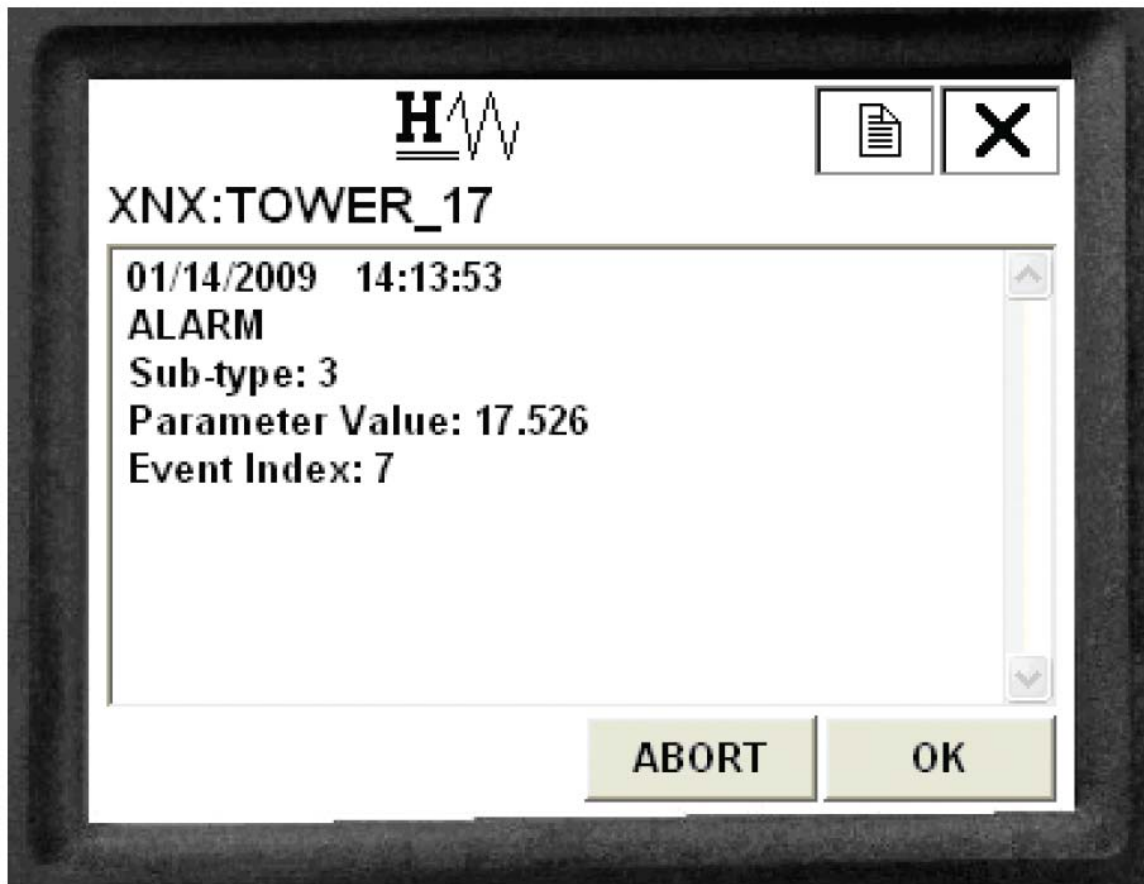

# HART® Test Menu

- The test menu provides methods for inhibiting the output, exercising the analogue output or simulating alarms or faults. These methods ease common tasks by providing a simple user interface.

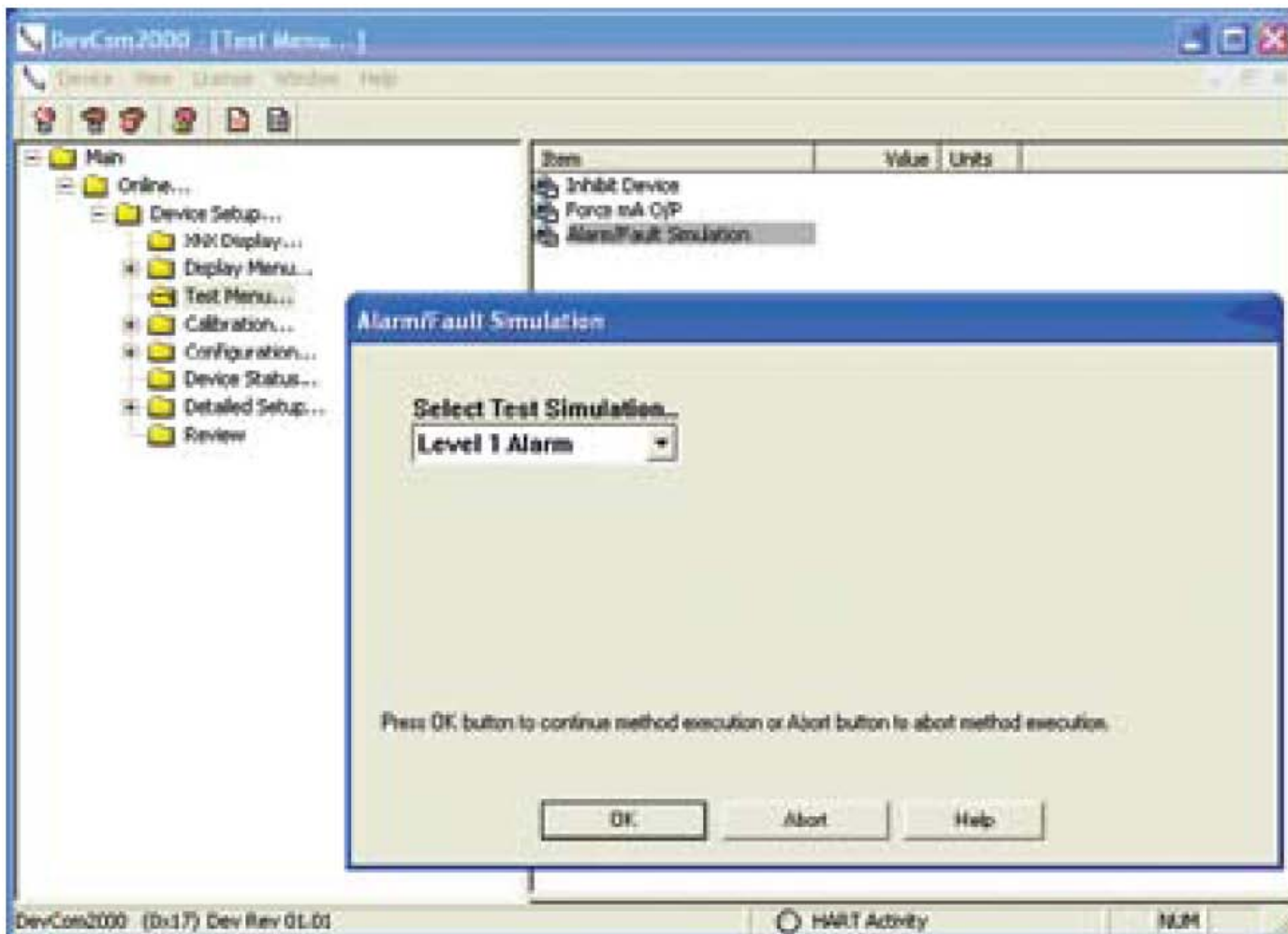

# HART® Calibration Menu

- The calibration menu permits calibrating zero or span and bump testing. Additionally, when fitted with a Searchline EXCEL gas detector, the Calibrate menu displays the optical signal strength for mechanical alignment. The gas calibrate operation is shown below.

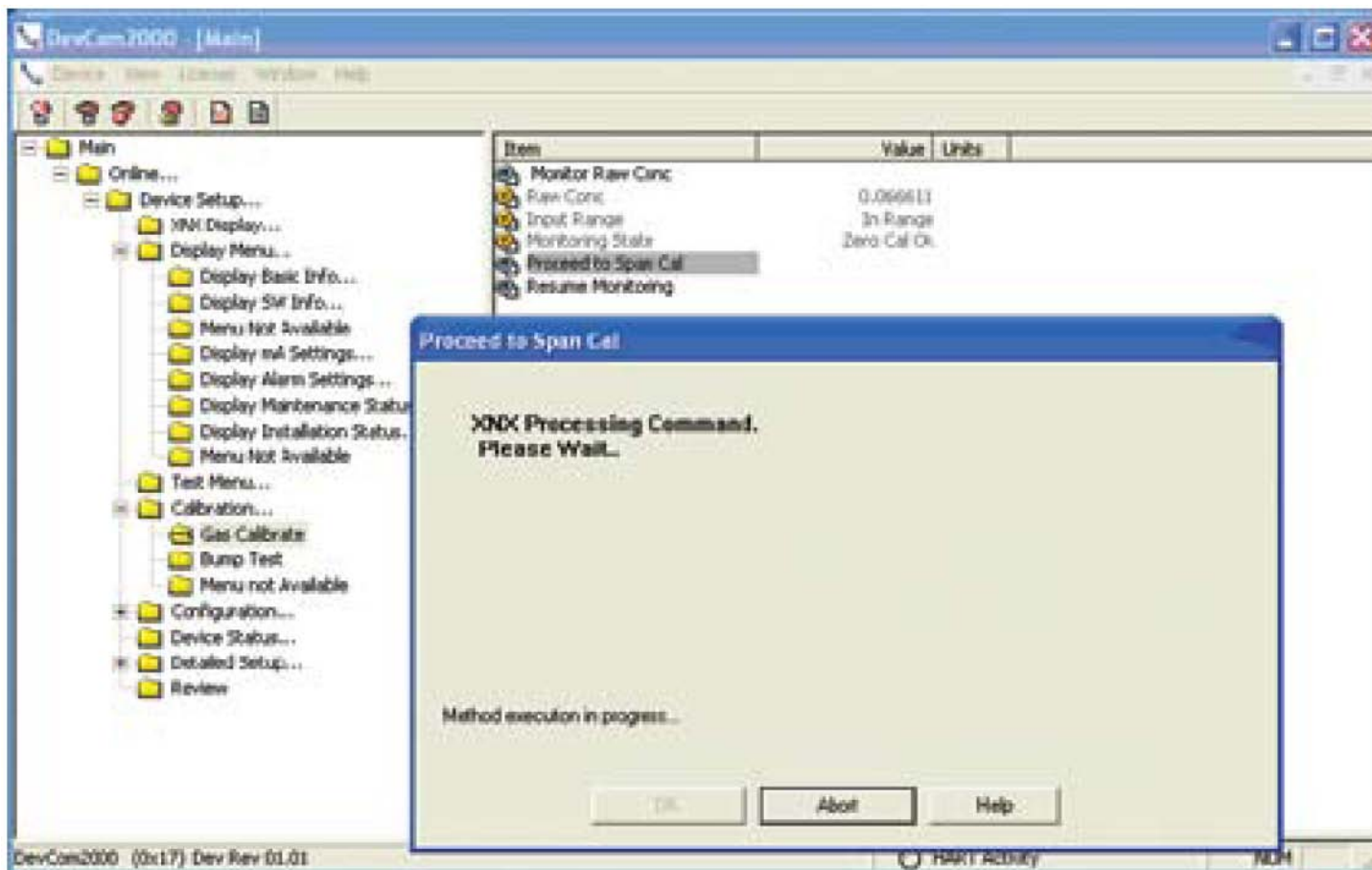

# XNX Configuration over HART®

- All user settings of the XNX can be made either at the local user interface or over HART. The configuration menu facilitates convenient setup of alarm levels as shown. Methods are also provided to set time, units and other parameters.

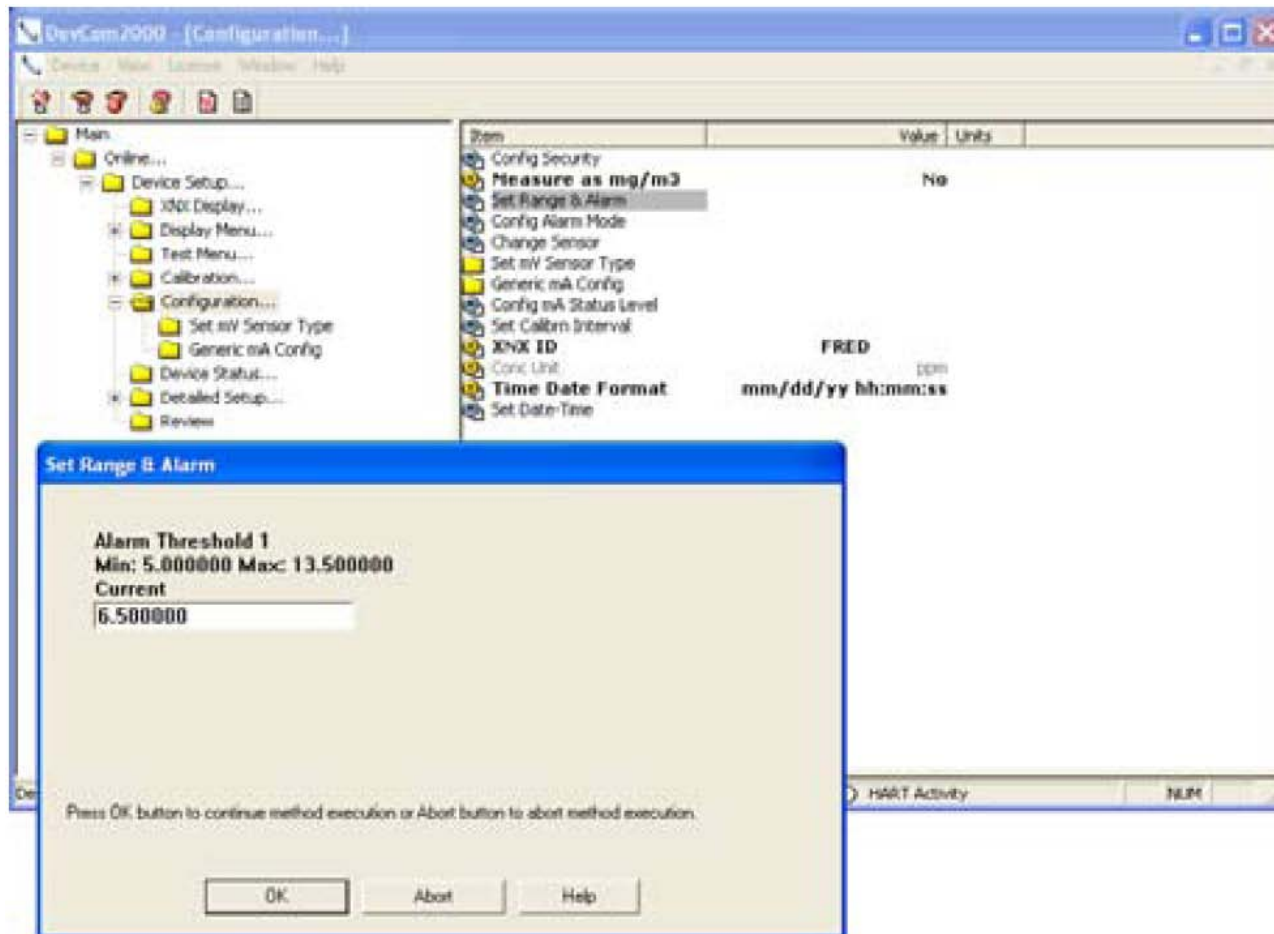

# HART® Handheld Online Menu

- When HART® communication is established with the XNX, the first menu displayed is the Root menu:

Main Menu	Key Sub Menus		
<b>Online...</b> 1 Device Setup 2 Concentration           0.00 %LEL 3 PV Alarm Typ 4 Monitoring State    Normal Monitoring 5 Reset Alarm Fault(s)   None 6 Gas Name            Methane 7 Sensor Type         Optima	<b>Device Setup...</b> 1 User Login 2 XNX Display... 3 Display Menu... 4 Test Menu... 5 Calibration... 6 Configuration... 7 Device Status... 8 Detailed Setup... 9 Review	<b>Current Login Level: Default</b> <b>Want to change Login Level</b> 1 Logout [Level 0] 2 Login [level1/2/3] 3 Exit	
<b>Online...</b> 1 Device Setup 2 Concentration           0.00 %LEL 3 PV Alarm Typ 4 Monitoring State    Normal Monitoring 5 Reset Alarm Fault(s)   None 6 Gas Name            Methane 7 Sensor Type         Optima	<b>Device Setup...</b> 1 User Login 2 XNX Display... 3 Display Menu... 4 Test Menu... 5 Calibration... 6 Configuration... 7 Device Status... 8 Detailed Setup... 9 Review	<b>XNX Display...</b> 1 Concentration           0.00 %LEL 2 PV Alarm Typ           None 3 Fault/Warn Number       F 4 Monitoring State       Normal Monitoring 5 Time Date Format   mm/dd/yy hh:mm:ss 6 Time Date Stamp   09/18/08 11:57:57 7 Gas Name            Methane LEL	
<b>Online...</b> 1 Device Setup 2 Concentration           0.00 %LEL 3 PV Alarm Typ 4 Monitoring State    Normal Monitoring 5 Reset Alarm Fault(s)   None 6 Gas Name            Methane 7 Sensor Type         Optima	<b>Device Setup...</b> 1 User Login 2 XNX Display... 3 Display Menu... 4 Test Menu... 5 Calibration... 6 Configuration... 7 Device Status... 8 Detailed Setup... 9 Review	<b>Display Menu...</b> 1 Reset Alarm Faults 2 Event History 3 Display Basic Info... 4 Display SW Info... 5 Display Optical Performance 6 Display mA Settings 7 Display Alarm Settings 8 Display Maintenance Status 9 Display Installation Status	<b>Display Basic Info...</b> 1 Gas Name            Methane LEL 2 XNX ID               SOUTH TOWER

# HART® Handheld Online Menu

Main Menu	Key Sub Menus		
<b>Online...</b> 1 Device Setup 2 Concentration 0.00 %LEL 3 PV Alm Typ 4 Monitoring State Normal Monitoring 5 Reset Alarm Fault(s) None 6 Gas Name Methane 7 Sensor Type Optima	<b>Device Setup...</b> 1 User Login 2 XNX Display... 3 Display Menu... 4 Test Menu... 5 Calibration... 6 Configuration... 7 Device Status... 8 Detailed Setup... 9 Review	<b>Display Menu...</b> 1 Reset Alarm Faults 2 Event History 3 Display Basic Info... 4 Display SW Info... 5 Display Optical Performance 6 Display mA Settings 7 Display Alarm Settings 8 Display Maintenance Status 9 Display Installation Status	<b>Display SW Info...</b> 1 Dev id 1081234 2 Fld dev rev 1 3 Sensor S/w Ver 48 4 Sensor s/n 0 5 Gas Name Methane LEL 6 XNX ID SOUTH TOWER
<b>Online...</b> 1 Device Setup 2 Concentration 0.00 %LEL 3 PV Alm Typ 4 Monitoring State Normal Monitoring 5 Reset Alarm Fault(s) None 6 Gas Name Methane 7 Sensor Type Optima	<b>Device Setup...</b> 1 User Login 2 XNX Display... 3 Display Menu... 4 Test Menu... 5 Calibration... 6 Configuration... 7 Device Status... 8 Detailed Setup... 9 Review	<b>Display Menu...</b> 1 Reset Alarm Faults 2 Event History 3 Display Basic Info... 4 Display SW Info... 5 Display Optical Performance 6 Display mA Settings 7 Display Alarm Settings 8 Display Maintenance Status 9 Display Installation Status	<b>Display Optical Performance...</b> 1 Signal Strength 0.96 2 Ref Sig Strength 1.12 3 Sam Sig Strength 1.06 4 Baseline 0.92 5 Dynamic Reserve 96 % 6 Window Temp 28 degC
<b>Online...</b> 1 Device Setup 2 Concentration 0.00 %LEL 3 PV Alm Typ 4 Monitoring State Normal Monitoring 5 Reset Alarm Fault(s) None 6 Gas Name Methane 7 Sensor Type Optima	<b>Device Setup...</b> 1 User Login 2 XNX Display... 3 Display Menu... 4 Test Menu... 5 Calibration... 6 Configuration... 7 Device Status... 8 Detailed Setup... 9 Review	<b>Display Menu...</b> 1 Reset Alarm Faults 2 Event History 3 Display Basic Info... 4 Display SW Info... 5 Display Optical Performance 6 Display mA Settings 7 Display Alarm Settings 8 Display Maintenance Status 9 Display Installation Status	<b>Display mA Settings...</b> 1 Overage Current 21 mA 2 Warning Current 3 mA 3 Inhibit Current 2 mA

# HART® Handheld Online Menu

Main Menu	Key Sub Menus		
<b>Online...</b> 1 Device Setup 2 Concentration           0.00 %LEL 3 PV Alarm Typ 4 Monitoring State       Normal Monitoring 5 Reset Alarm Fault(s)   None 6 Gas Name                Methane 7 Sensor Type             Optima	<b>Device Setup...</b> 1 User Login 2 XNX Display... 3 Display Menu... 4 Test Menu... 5 Calibration... 6 Configuration... 7 Device Status... 8 Detailed Setup... 9 Review	<b>Display Menu...</b> 1 Reset Alarm Faults 2 Event History 3 Display Basic Info... 4 Display SW Info... 5 Display Optical Performance 6 Display mA Settings 7 Display Alarm Settings 8 Display Maintenance Status 9 Display Installation Status	<b>Display Alarm Settings...</b> 1 PV URV                   100.000 %LEL 2 PV LRV                   0.000 %LEL 2 Alarm Thresholds 1     20 %LEL 3 Alarm Thresholds 2     40 %LEL 4 Alarm Config             0x0C 5 Board Type               Modbus/RTU Interf...
<b>Online...</b> 1 Device Setup 2 Concentration           0.00 %LEL 3 PV Alarm Typ 4 Monitoring State       Normal Monitoring 5 Reset Alarm Fault(s)   None 6 Gas Name                Methane 7 Sensor Type             Optima	<b>Device Setup...</b> 1 User Login 2 XNX Display... 3 Display Menu... 4 Test Menu... 5 Calibration... 6 Configuration... 7 Device Status... 8 Detailed Setup... 9 Review	<b>Display Menu...</b> 1 Reset Alarm Faults 2 Event History 3 Display Basic Info... 4 Display SW Info... 5 Display Optical Performance 6 Display mA Settings 7 Display Alarm Settings 8 Display Maintenance Status 9 Display Installation Status	<b>Display Maintenance Status..</b> 1 Sensor Type             ECC 2 Sensor Life              0 Hours
<b>Online...</b> 1 Device Setup 2 Concentration           0.00 %LEL 3 PV Alarm Typ 4 Monitoring State       Normal Monitoring 5 Reset Alarm Fault(s)   None 6 Gas Name                Methane 7 Sensor Type             Optima	<b>Device Setup...</b> 1 User Login 2 XNX Display... 3 Display Menu... 4 Test Menu... 5 Calibration... 6 Configuration... 7 Device Status... 8 Detailed Setup... 9 Review	<b>Display Menu...</b> 1 Reset Alarm Faults 2 Event History 3 Display Basic Info... 4 Display SW Info... 5 Display Optical Performance 6 Display mA Settings 7 Display Alarm Settings 8 Display Maintenance Status 9 Display Installation Status	<b>Display Installation Status...</b> 1 Power Supply Volt...   19403 mVolt 2 Operating Voltage       3297 mVolt 3 Sensor I/P Voltage      0 mVolt 4 Sensor Voltage          0 mVolt 5 XNX Temp                 33 degC 6 Sensor Temp             41 degC 7 Loop current             4.000 mA

# HART® Handheld Online Menu

Main Menu	Key Sub Menus
<b>Online...</b> 1 Device Setup 2 Concentration 0.00 %LEL 3 PV Alarm Typ 4 Monitoring State Normal Monitoring 5 Reset Alarm Fault(s) None 6 Gas Name Methane 7 Sensor Type Optima	<b>Device Setup...</b> 1 User Login 2 XNX Display... 3 Display Menu... <b>4 Test Menu...</b> 5 Calibration... 6 Configuration... 7 Device Status... 8 Detailed Setup... 9 Review  <b>Test Menu...</b> 1 Inhibit Long-term 2 Force mA O/P 3 Alarm/Fault Simulation
<b>Online...</b> 1 Device Setup 2 Concentration 0.00 %LEL 3 PV Alarm Typ 4 Monitoring State Normal Monitoring 5 Reset Alarm Fault(s) None 6 Gas Name Methane 7 Sensor Type Optima	<b>Device Setup...</b> 1 User Login 2 XNX Display... 3 Display Menu... <b>4 Test Menu...</b> <b>5 Calibration...</b> 6 Configuration... 7 Device Status... 8 Detailed Setup... 9 Review  <b>Calibration...</b> 1 Gas Calibrn 2 Bump Test 3 Calibrate mA Offset 4 Soft Reset 5 Align Excel
<b>Online...</b> 1 Device Setup 2 Concentration 0.00 %LEL 3 PV Alarm Typ 4 Monitoring State Normal Monitoring 5 Reset Alarm Fault(s) None 6 Gas Name Methane 7 Sensor Type Optima	<b>Device Setup...</b> 1 User Login 2 XNX Display... 3 Display Menu... <b>4 Test Menu...</b> <b>5 Calibration...</b> <b>6 Configuration...</b> 7 Device Status... 8 Detailed Setup... 9 Review  <b>Configuration...</b> 1 Config Security 2 Measure as mg/m3 No 3 Set Range & Alarm 4 Config Alarm Mode 5 Fieldbus Option 6 Set mV Sensor Type 7 Gas Selection 8 Config mA Status L... 9 Set Calibrn Interval XNX ID SOUTH TOWER Conc Unit %LEL Time Date Format mm/dd/yy hh:mm:ss Set Date-Time

# HART® Handheld Online Menu

Main Menu	Key Sub Menus		
<b>Online...</b> 1 Device Setup 2 Concentration           0.00 %LEL 3 PV Alm Typ 4 Monitoring State       Normal Monitoring 5 Reset Alarm Fault(s)   None 6 Gas Name               Methane 7 Sensor Type            Optima	<b>Device Setup...</b> 1 User Login 2 XNX Display... 3 Display Menu... 4 Test Menu... 5 Calibration... 6 Configuration... 7 Device Status... 8 Detailed Setup... 9 Review	<b>Detailed Setup...</b> 1 Output Condition... 2 Device Information...	
<b>Online...</b> 1 Device Setup 2 Concentration           0.00 %LEL 3 PV Alm Typ 4 Monitoring State       Normal Monitoring 5 Reset Alarm Fault(s)   None 6 Gas Name               Methane 7 Sensor Type            Optima	<b>Device Setup...</b> 1 User Login 2 XNX Display... 3 Display Menu... 4 Test Menu... 5 Calibration... 6 Configuration... 7 Device Status... 8 Detailed Setup... 9 Review	<b>Review</b> 1 Manufacturer           Honeywell 2 Model                   XNX 3 Sensor Type            Optima 4 PV                       %LEL 5 Info Min Range         100.00 %LEL 6 Info Max Range         100.00 %LEL 7 PV % Range             0.000 % 8 PV Xfer fnctn         Linear 9 PV                       4.000 mA PV Alm typ             None Tag                     S. TOWER Long tag Descriptor             SOUTH TOWER Message                CRACKING TOWER Final asmbly num       0 Dev id                  1081234 Universal rev           6 Fld dev rev             1 Software rev           38 Poll addr               0 Loop Curnt Mode       Enabled Cfg chng count         6 Num req preams         9 Num resp preams       7	

- **The XNX gas detector may be fitted with the optional Modbus interface card (P/N XNX-MB). Authoritative information on the Modbus protocol can be found at [www.modbus.org](http://www.modbus.org). The XNX supports Modbus/RTU over an RS-485 physical layer. The interface is isolated and includes a switchable 120 Ohm termination resistor. Baud rates from 1200 to 38,400 are supported with 19,200 as the default.**
- **Most of the operations that are possible with the HART and local user interfaces can also be performed using the Modbus interface. This includes test, calibration and configuration operations. However, this Appendix only describes how to monitor XNX status using Modbus. Information on more advanced operations is contained in technical publication 1998-0746.**
- **Some of the relevant Modbus holding registers are listed in the table following. Monitoring the XNX status is simpler than it looks – most installations will read only the first five registers. (This is four data.) Note that the assignment of first eight registers (or six data) is identical to the Honeywell Analytics XCD gas detector.**
- **Building an effective Modbus automatic gas detection system requires checking for faults (using `iFaultWarnNumber` or `iAlmFltLev`) and checking `iMonitoringState` to confirm that the XNX is not inhibited or in calibration.**

# Modbus® Registers

Modbus Holding Register Address	Datatype	Variable Name	Description
40001	Int16	ID	MSB always 0x24 to facilitate automatic identification. LSB repeat of Modbus address.
40002	Int16	ID	Identical to 40001
40003 to 40004	Float32	fCurrentConc	The reported gas concentration in current measurement units. For example, methane at 50% LEL would be reported as 50.0 here. This concentration is forced to zero during inhibit mode.
40005	int16	iFaultWarnNumber	This is the integer representation of the fault status. If any fault exists this will take a value in the range 1000 to 1999. Otherwise, if any warning exists, this will take a value in the range 1 to 999. Normally, this has the value zero. For example, if the XNX temperature is out of range, this will take the value 1103.
40006	int8	iAlmFltLev	This register contains 4 meaningful bits regarding the presence of alarms or faults. The bit assignments are as follows: Bit 0: AL1 active Bit 1: AL2 active Bit 4: Warning active Bit 6: Fault Active All others: For future expansion
40007	uint8	iMonitoringState	This has the following meanings: <ul style="list-style-type: none"> <li>0 reserved</li> <li>1 normal monitoring</li> <li>2 in warm-up</li> <li>3 long-term inhibit</li> <li>4 alarm simulation</li> <li>5 fault simulation</li> <li>6 Loop current stimulated</li> <li>7 in warning MFlt</li> <li>8 in Instrument Flt</li> <li>9 in beam block</li> <li>10 in bump test</li> <li>11 short-term inhibit</li> <li>12 performing zero calibration</li> <li>13 performing span calibration</li> <li>14 in pre-zero calibration</li> <li>15 in pre-span calibration</li> <li>16 in post-zero calibration, successful</li> <li>17 in post-span calibration, successful</li> <li>18 in post-zero calibration, failed</li> <li>19 in post-span calibration, failed</li> <li>20 in align Excel mode</li> <li>21-255 for future expansion</li> </ul>
40008	int16	iHeartBeat	This Heartbeat is provided to facilitate detection of communications problems in programming environments where the transport-layer communication error information is unavailable. This increments approximately every 5 seconds.  It is the responsibility of the system integrator to notify plant personnel if a Modbus master fails to communicate with the XNX. This register can facilitate this notification.
40009 to 40010	float32	fSensorLifeDays	This indicates the time remaining before the ECC sensor must be calibrated or replaced.

# Modbus® Registers

Modbus Holding Register Address	Datatype	Variable Name	Description
40011	int8	iMeasurementUnits	The meaning of this datum is as enumerated below: 0 Default 1 mg/m3 2 g/m3 3 %vol 4 ppm 5 %LEL 6 UEG 7 Ratio 8 %LEL*M 9 ppm*m 10 EG*m 11 %vol * meter 12 to 255 for future expansion
40012 to 40014	string[5]	strGenericUnits	User-defined 5 character string description for installed generic mA sensor
40015	int8	iWinTemp	If a Searchline Excel is fitted, this is the temperature of the window. Otherwise, this is the temperature of the window.
40016	int8	iTransTemp	Temperature of the XNX in Celcius.
40017	int8	iSensorTemp	Temperature of the sensor (Optima, Excel, ECC, etc)
40018 to 40026	string[18]	strTransmitterID	User-configured transmitter name.
40027 to 40035	string[18]	sDateTime	Format is "mm/dd/yy hh:mm:ss". Month and day inverted if so configured.
40036	int8	iSensorType	The meaning of this datum is as enumerated below 1 mV Bridge 2 Electrochemical Cell with toxic cartridge 3 Electrochemical Cell with O2 cartridge 4 Optima 5 Excel 7 generic mA input Others for future expansion
40037	float32	f_mA_Out	The current produced by the XNX in milliamperes.
40038	int16	iTransVoltage24000	The voltage supplied to the XNX at the nominal 24.0 volt input, in millivolts.
40039	int16	iTransVoltage_3300	The voltage on a nominal 3.3 volt supply in the XNX, in millivolts.

# Modbus® Registers

Modbus Holding Register Address	Datatype	Variable Name	Description
40041	int16	iOptional3300	The voltage on a nominal 3.3 volt supply in the XNX option board, in millivolts.
40042	int16	iPersonality3300	The voltage on a nominal 3.3 volt supply in the XNX personality board, in millivolts.
40043	int16	iPersonality5000	The voltage on a nominal 5.0 volt supply in the XNX personality board, in millivolts.
40044	int16	iSensVoltage24000	The voltage supplied to an Optima or Excel sensor at the nominal 24.0 volt input, in millivolts.
40045	int16	iSensVoltage_5000	The voltage on a nominal 5.0 volt supply in Optima or Excel, in millivolts.
40046 to 40079	Contact HA for details.		
40080 to 40081	int32	iTransSn	Serial number of XNX.
40082 to 40083	int32	iSensSn	Serial number of Optima, Excel, or ECC cartridge.
40084	int8	iSensSwVer	Integer representation of software version in external sensor or mV personality module
40085	int8	iTransSwVer	Software version of XNX.
40086 to 40155	Contact HA for details.		



**D**ETECTION | **S**AFETY | **P**ROTECTION

For Pricing or Further  
Information Please Contact Us.



**+441158390495**



**www.manonglobal.com**



**sales@manonglobal.com**

---

**Leading UK Suppliers In  
Gas Detection, Safety & Protection  
Products  
Brand New & Genuine OEM Parts  
UK & Worldwide Deliveries Available**



Worldwide Delivery



1000+ Genuine Parts & Equipment